

# Standard XI

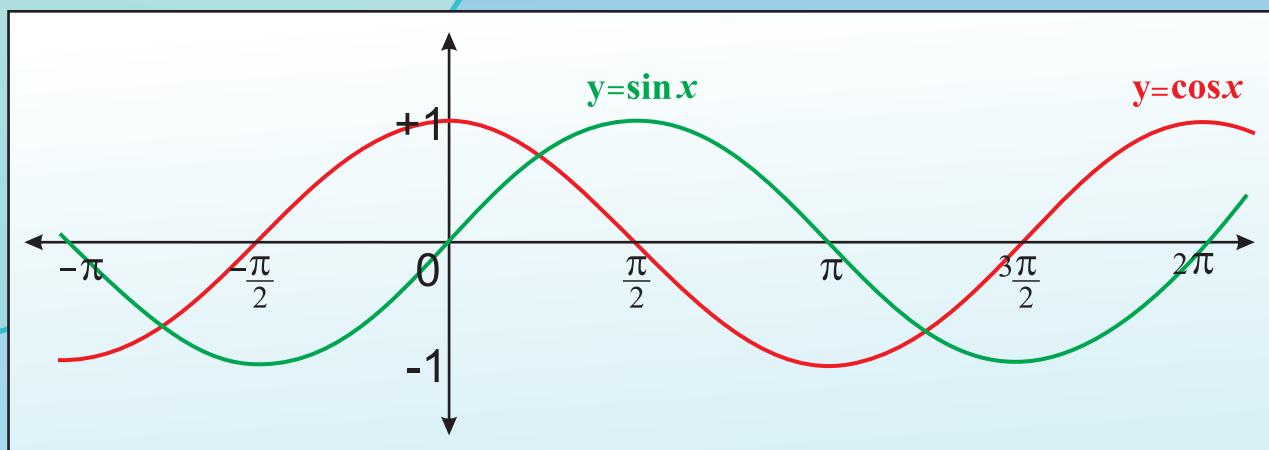

# Mathematics & Statistics

(Arts & Science) Part 1

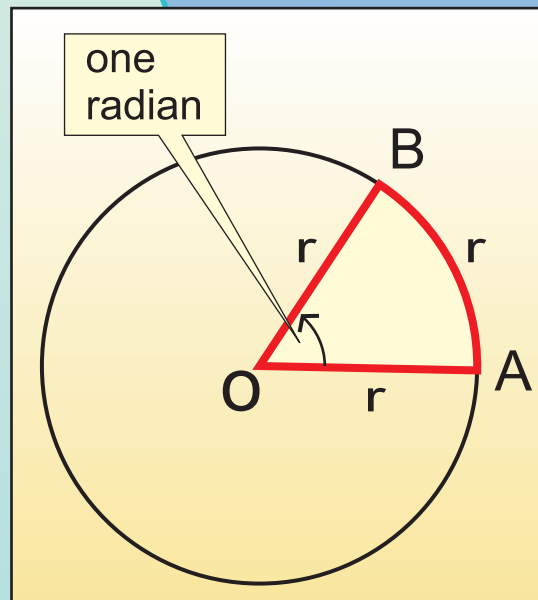

The Coordination Committee formed by GR No. Abhyas - 2116/(Pra.Kra.43/16) SD - 4 Dated 25.4.2016 has given approval to prescribe this textbook in its meeting held on 20.06.2019 and it has been decided to implement it from the educational year 2019-20.

# Mathematics and Statistics

## (Arts and Science)

### Part - I

#### STANDARD - XI



2019

**Maharashtra State Bureau of Textbook Production and Curriculum Research,  
Pune - 411 004**



T5X2F1

Download DIKSHA App on your smartphone. If you scan the Q.R.Code on this page of your textbook, you will be able to access full text and the audio-visual study material relevant to each lesson provided as teaching and learning aids.

**First Edition : 2019** © Maharashtra State Bureau of Textbook Production and Curriculum Research, Pune- 411 004.

Maharashtra State Bureau of Textbook Production and Curriculum Research reserves all rights relating to the book. No part of this book should be reproduced without the written permission of the Director, Maharashtra State Bureau of Textbook Production and curriculum Research, Pune.

### **Mathematics - I (Science and Arts) Committee Members**

Dr. Mangala Narlikar	(Chairman)
Dr. Sharad Gore	(Member)
Shri. Prahallad Chippalagatti	(Member)
Shri. Prasad Kunte	(Member)
Shri. Sujit Shinde	(Member)
Smt. Prajakti Gokhale	(Member)
Shri. Sandeep Panchbhai	(Member)
Shri. Ramakant Sarode	(Member)
Smt. Pooja Jadhav	(Member)
Smt. Ujjwala Godbole	(Member-Secretary)

### **Cover, Illustrations and Computer Drawings**

**Shri. Sandip Koli,**  
Artist

### **Typesetter**

Baladev Computers

### **Co-ordinator**

**Ujjwala Shrikant Godbole**  
I/C Special Officer for Mathematics

### **Mathematics - I (Science and Arts) Study Group Members**

Dr. Ishwar Patil	Dr. Pradeep Mugale
Dr. Pradnyankumar Bhojankar	Shri. Milind Patil.
Shri. Pradeepkumar Bhavsar	Shri. Balkrishna Mapari
Shri. Prafullchandra Pawar	Shri. Uday Mahindrakar
Shri. Devanand Bagul	Smt. Swati Powar
Shri. Swapnil Shinde	Smt. Mahadevi Mane
Shri. Sachin Batwal	Smt. Nileema Khaldkar
Smt. Deepti Kharapas	Shri. Amit Totade
Shri. Pramod Deshpande	Smt. Gauri Prachand
Shri. Sharadchandra Walagade	Smt. Supriya Abhyankar
Shri. Dhananjay Panhalkar	Shri. Dilip Panchamia
Shri. Vinayak Godbole	

### **Production**

**Sachchitanand Aphale**  
Chief Production Officer

**Sanjay Kamble**  
Production Officer

**Prashant Harne**  
Asst. Production Officer

### **Paper**

70 GSM Cream wove

### **Print Order No.**

N/PB/2019-20/25,000

### **Printer**

CREATIVE PRINT MEDIA, NAVI MUMBAI

### **Publisher**

**Vivek Uttam Gosavi, Controller**  
Maharashtra State Textbook Bureau,  
Prabhadevi Mumbai- 400 025

**Chief Co-ordinator**  
Smt. Prachi Ravindra Sathe

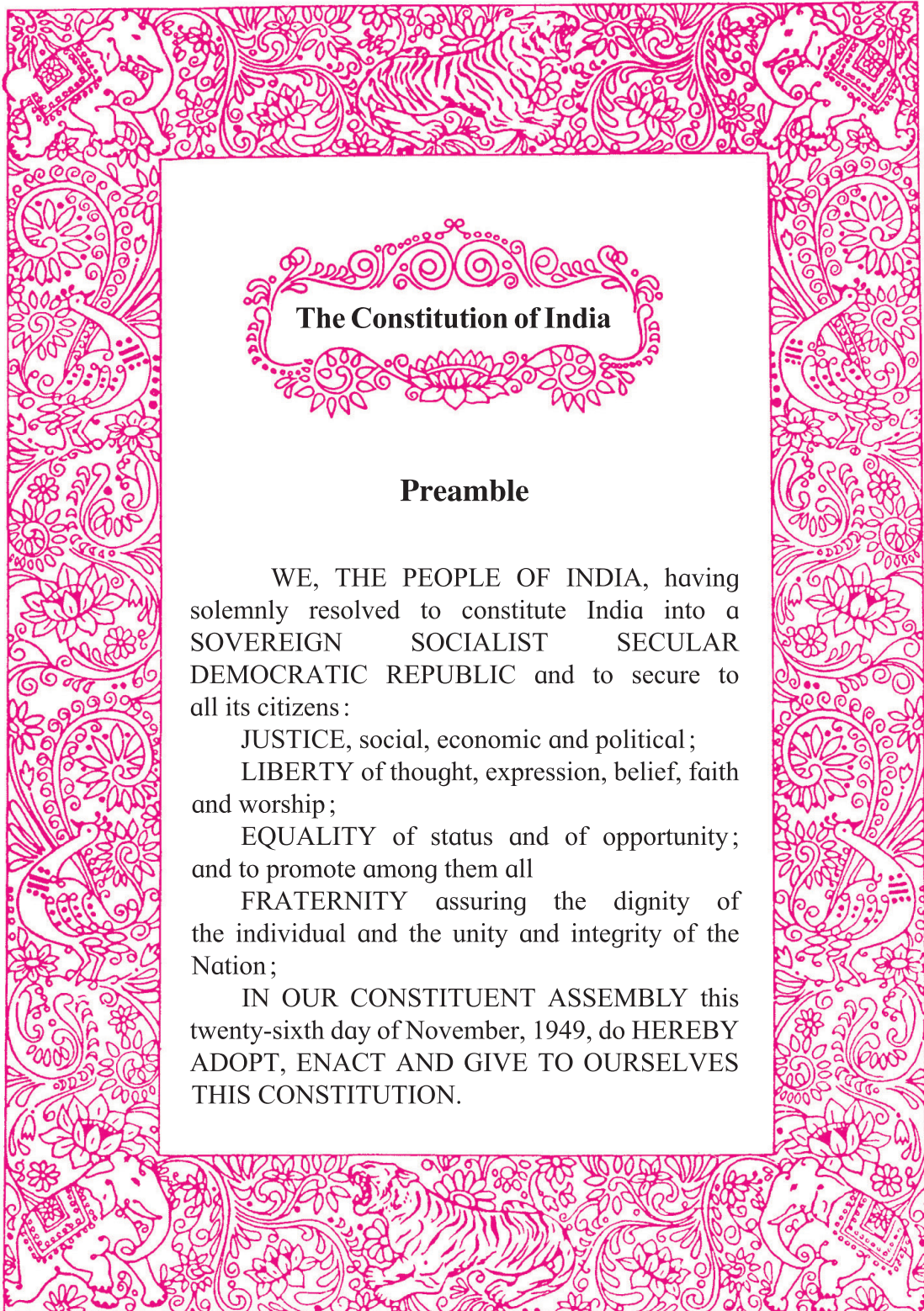

## The Constitution of India

### Preamble

WE, THE PEOPLE OF INDIA, having solemnly resolved to constitute India into a SOVEREIGN SOCIALIST SECULAR DEMOCRATIC REPUBLIC and to secure to all its citizens :

JUSTICE, social, economic and political ;

LIBERTY of thought, expression, belief, faith and worship ;

EQUALITY of status and of opportunity ; and to promote among them all

FRATERNITY assuring the dignity of the individual and the unity and integrity of the Nation ;

IN OUR CONSTITUENT ASSEMBLY this twenty-sixth day of November, 1949, do HEREBY ADOPT, ENACT AND GIVE TO OURSELVES THIS CONSTITUTION.

## NATIONAL ANTHEM

Jana-gana-mana-adhināyaka jaya hē  
Bhārata-bhāgya-vidhātā,

Panjāba-Sindhu-Gujarāta-Marāthā  
Drāvida-Utkala-Banga

Vindhya-Himāchala-Yamunā-Gangā  
uchchala-jaladhi-taranga

Tava subha nāmē jāgē, tava subha āsisa māgē,  
gāhē tava jaya-gāthā,

Jana-gana-mangala-dāyaka jaya hē  
Bhārata-bhāgya-vidhātā,

Jaya hē, Jaya hē, Jaya hē,  
Jaya jaya jaya, jaya hē.

## PLEDGE

India is my country. All Indians  
are my brothers and sisters.

I love my country, and I am proud  
of its rich and varied heritage. I shall  
always strive to be worthy of it.

I shall give my parents, teachers  
and all elders respect, and treat  
everyone with courtesy.

To my country and my people,  
I pledge my devotion. In their  
well-being and prosperity alone lies  
my happiness.

## PREFACE

Dear Students,

Welcome to the eleventh standard!

You have successfully completed your secondary education and have entered the higher secondary level. You will now need to learn certain mathematical concepts and acquire some statistical skills to add more applicability to your work. Maharashtra State Bureau of Textbook Production and Curriculum Research has modified and restructured the curriculum in Mathematics in accordance with changing needs.

The curriculum of Mathematics is divided in two parts. Part 1 covers topics in Trigonometry, Algebra, Co-ordinate Geometry and Statistics. Part 2 covers Complex Numbers, Sets and Relations, Calculus and Combinatorics. There is a special emphasis on applications. Activities are added in every chapter for creative thinking.

Some material will be made available on E-balbharati website (ealbharati.in). It contains a list of specimen practical problems on each chapter. Students should complete the practical exercises under the guidance of their teachers. Maintain a journal and take teacher's signature on every completed practical.

You are encouraged to use modern technology in your studies. Explore the Internet for more recent information and problems on topics in the curriculum. You will enjoy learning if you study the textbook thoroughly and manage to solve problems.

On the title page Q.R. code is given. It will help you to get more knowledge and clarity about the contents.

This textbook is prepared by Mathematics Subject Committee and members of study group. This book has also been reviewed by senior teachers and subject experts. The Bureau is grateful to all of them and would like to thank for their contribution in the form of creative writing, constructive criticism and valuable suggestions in making this book useful to you and helpful to your teachers.

The Bureau hopes that the textbook will be received well by all stakeholders in the right spirit.

You are now ready to study. Best wishes for a happy learning experience.

**Pune**

**Date : 20 June 2019**

**Indian Solar Date : 30 Jyeshtha 1941**



**(Dr. Sunil Magar)**  
**Director**

Maharashtra State Bureau of Textbook  
Production and Curriculum Research, Pune.

## XI Mathematics and Statistics (Part I) for Arts and Science

Sr. No	Area	Topic	Competency Statement
1	Angle and Its measurement	Angle	<p>The student will be able to -</p> <ul style="list-style-type: none"><li>• understand angle of any measure.</li><li>• understand different systems of measurement of angle and relations between them.</li><li>• convert an angle from one system to the other.</li></ul>
2	Trigonometric Functions	Trigonometric Functions	<ul style="list-style-type: none"><li>• understand definitions of trigonometric functions of angle of any measure.</li><li>• find the values of trigonometric functions of certain angles.</li><li>• draw graphs of trigonometric functions.</li></ul>
3	Trigonometric Functions of compound angles and factorization formulae	Trigonometric Functions of compound angles	<ul style="list-style-type: none"><li>• find the trigonometric functions of sum or difference of the angles.</li><li>• find the trigonometric functions of multiple and sub-multiple angles.</li><li>• express the sum or difference of two trigonometric functions as product</li><li>• learn some rules of trigonometric ratios of angles of a triangle.</li></ul>
4	Determinants and Matrices	Determinant	<ul style="list-style-type: none"><li>• find value of a determinant.</li><li>• reduce determinant to simple form.</li><li>• solve linear equations in 2 or 3 variables</li><li>• find area of triangle using determinants.</li></ul>
		Matrices	<ul style="list-style-type: none"><li>• understand types of matrices.</li><li>• Perform algebraic operations of the matrices.</li></ul>

5	Straight Line	Straight Line	<ul style="list-style-type: none"><li>• understand locus and its equation.</li><li>• find equation of a straight line in different forms.</li><li>• find angle between given two straight lines and the distance of a point from given line.</li></ul>
6	Circle	Circle	<ul style="list-style-type: none"><li>• find equation of circle satisfying given conditions.</li><li>• learn and use the properties of circle.</li><li>• find the equation of tangent to the circle.</li></ul>
7	Conic Section	Parabola, Ellipse, Hyperbola	<ul style="list-style-type: none"><li>• find the equations of conic sections satisfying given conditions.</li><li>• learn and use the properties of conics.</li><li>• find the equation of tangent to the conic.</li></ul>
8	Measures of dispersion	Measures of dispersion	<ul style="list-style-type: none"><li>• calculate range, standard deviation and variance from given data.</li></ul>
9	Probability	Probability	<ul style="list-style-type: none"><li>• calculate probability of an event and learn conditional probability</li><li>• learn and use Baye's theorem and its applications</li></ul>

**Note :-** Extra examples for competitive section and practice are given on e-balbharti. The activities which can be conducted as a part of practicals are also mentioned in pdf form on our website.

## INDEX

Sr. No.	Chapter No.	Page No.
1	Angle and its Measurement	1
2	Trigonometry - I	14
3	Trigonometry - II	35
4	Determinants and Matrices	59
5	Straight Line	103
6	Circle	127
7	Conic Sections	140
8	Measures of Dispersion	179
9	Probability	193
	Answers	216

# 1 Angle and its measurement

## Let's Study

- Directed angle.
- Angles of different measurements
- Units of measure of an angle
- Length of an arc of a circle.
- Area of a sector of a circle.

## Let's Recall

- We know how to draw the acute angles of different measures.
- In a circle we can find arc length and area of a sector in terms of the central angle and the radius.

### Activity No. 1

Draw the angle ABC of measure  $40^\circ$

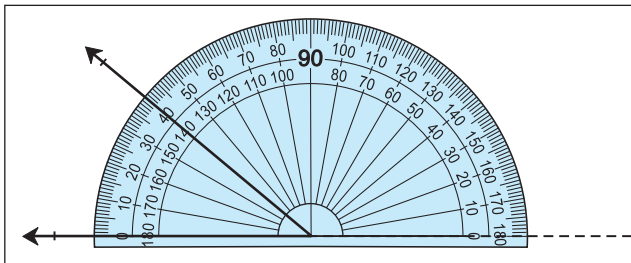

Fig. 1.1

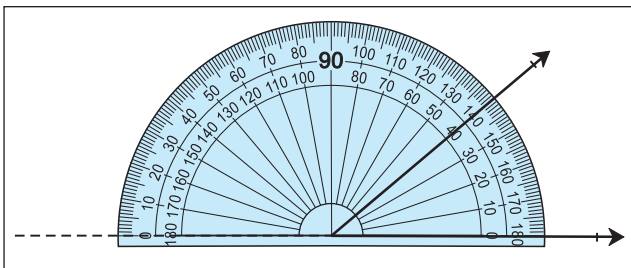

Fig. 1.2

In the Figs 1.1 and 1.2 both the angles are of  $40^\circ$ . But one is measured in anticlockwise direction and the other is measured in clockwise direction.

Now we will differentiate between such angles.

## Let's Learn

### 1.1 Directed Angles:

Consider the ray OA. Rotate it about O till it takes the position OB as shown in Fig. 1.3. Then angle so obtained due to the rotation is called directed angle AOB. We define the notion of directed angle as follows:

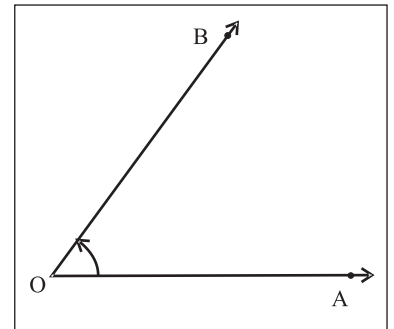

Fig. 1.3

#### Definition:

The ordered pair of rays  $(\vec{OA}, \vec{OB})$  together with the rotation of the ray OA to the position of the ray OB is called the **directed angle**  $\sphericalangle AOB$ .

If the rotation of the initial ray is anticlockwise then the measure of directed angle is considered as **positive** and if it is clockwise then the measure of directed angle is considered as **negative**. In the ordered pair  $(\vec{OA}, \vec{OB})$ , the ray OA is called the **initial arm** and the ray OB is called the **terminal arm**.

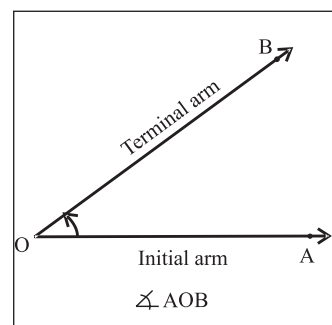

Fig. 1.3(a)

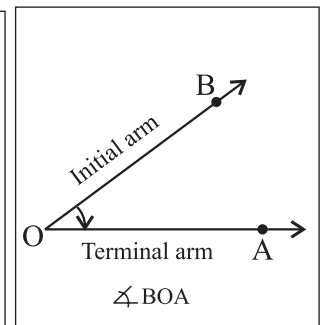

Fig. 1.3(b)

O is called the vertex as shown in fig 1.3(a) and 1.3(b).

Observe Fig 1.3(b) and note that

$$(\vec{OA}, \vec{OB}) \neq (\vec{OB}, \vec{OA})$$

$$\angle AOB \neq \angle BOA$$

$\angle AOB \neq \angle BOA$  even though they have same amount of rotation.

**Zero angle:**

If the ray OA has zero rotation, that is it does not rotate, the initial arm itself is a terminal arm OB, the angle so formed is zero angle.

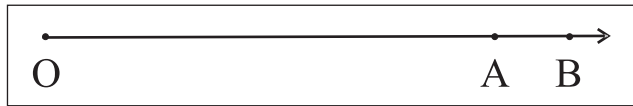

Fig. 1.4

**One rotation angle:**

After one complete rotation if the initial ray OA coincides with the terminal ray OB then so formed angle is known as one rotation angle  $m\angle AOB = 360^\circ$ .

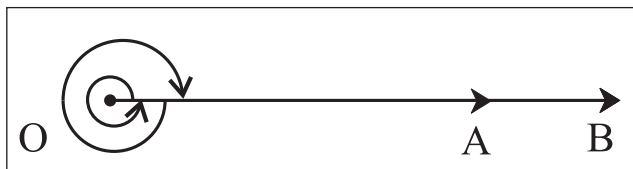

Fig. 1.5

**Straight angle:**

After the rotation, if the initial ray OA and the terminal ray OB are in opposite directions then directed angle so formed is known as straight angle (fig. 1.4).

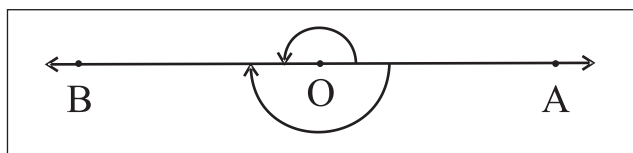

Fig. 1.6

Note that in this case AOB is a straight line.

and, half of one rotation angle is straight angle.

**Right angle:**

One fourth of one rotation angle is called as one right angle, it is also half of a straight angle. One rotation angle is four right angles.

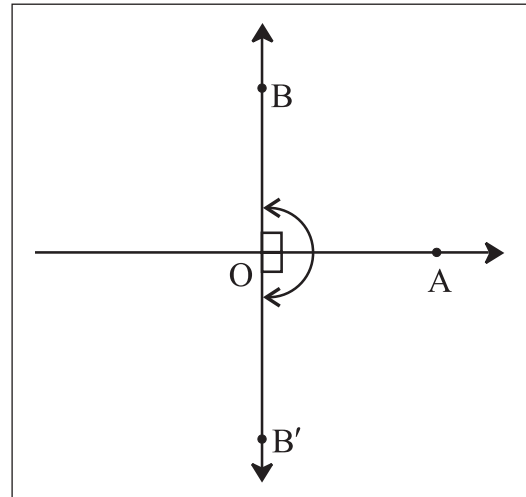

Fig. 1.7

**Angles in Standard position :**

In the rectangular co-ordinate system, a directed angle with its vertex at origin O and the initial ray along the positive X-axis, is called angle in standard position.

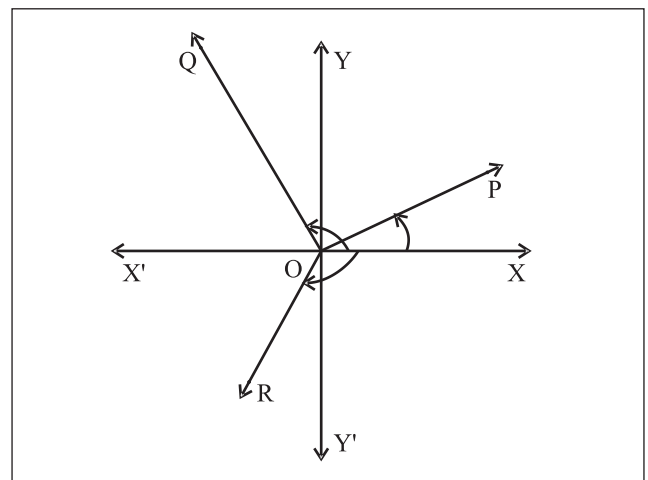

Fig. 1.8

In adjacent Fig. 1.8,  $\angle XOP$ ,  $\angle XOQ$  and  $\angle XOR$  are in standard positions. But,  $\angle POQ$  is not in standard position.

**Angle in a Quadrant:**

A directed angle in standard position is said to be in a particular quadrant if its terminal ray lies in that quadrant.

In Fig. 1.8, directed angles  $\sphericalangle XOP$ ,  $\sphericalangle XOQ$  and  $\sphericalangle XOR$  lie in first, second and third quadrants respectively.

**Quadrantal Angles:**

A directed angle in standard position whose terminal ray lies along X-axis or Y-axis is called a **quadrantal angle**.

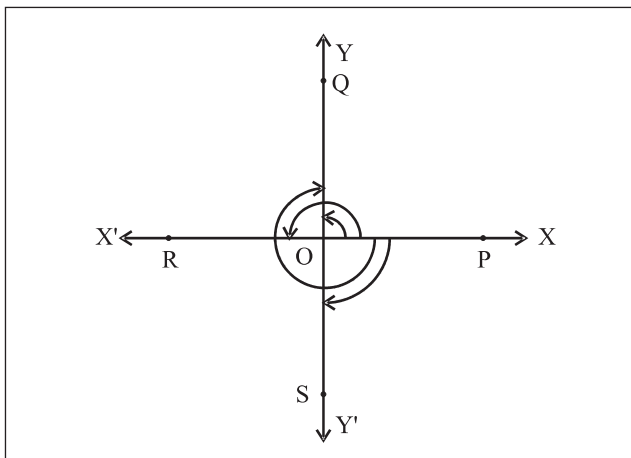
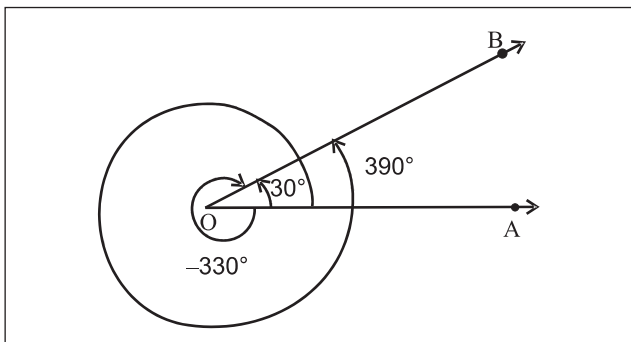

**Fig. 1.9**

In Fig. 1.9,  $\sphericalangle XOP$ ,  $\sphericalangle XOQ$ ,  $\sphericalangle XOR$  and  $\sphericalangle XOS$  are all quadrantal angles.

**Co-terminal angles:**

Directed angles of different amount of rotation having the same positions of, initial rays and terminal rays are called **co-terminal angles**.



**Fig. 1.10 (a)**

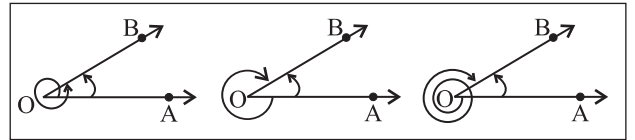

**Fig. 1.10 (b)**

In Fig. 1.10(a), the directed angles having measure  $30^\circ$ ,  $390^\circ$ ,  $-330^\circ$  have the same initial arm, ray  $\vec{OA}$  and the same terminal arm, ray  $\vec{OB}$ . Hence, these angles are co-terminal angles.

If the two directed angles are co-terminal angles then difference between measures of these two directed angles is an integral multiple of  $360^\circ$  e.g. in figure 1.10(a),  $390^\circ - (-330^\circ) = 720^\circ = 2 \times 360^\circ$ .

**1.1.1 Measures of angles:**

The amount of rotation from the initial ray OA to the terminal ray OB gives the measure of angle AOB. It is measured in two systems.

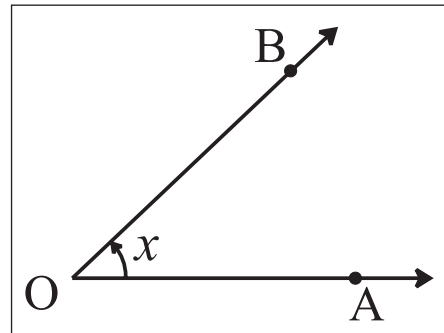

**Fig. 1.11**

- 1) Sexagesimal system (Degree measure)
- 2) Circular system (Radian measure)

**1.1.2 Sexagesimal System (Degree Measure):**

In this system, the unit of measurement of angle is a degree.

One rotation angle is divided into 360 equal parts, the measure of each part is called as one degree angle.

$$\therefore \left(\frac{1}{360}\right)^{\text{th}} \text{ part of one complete rotation}$$

is called **one degree** and is denoted by  $1^\circ$ .

$\left(\frac{1}{60}\right)^{\text{th}}$  part of one degree is called one minute and is denoted by 1'.

$\left(\frac{1}{60}\right)^{\text{th}}$  part of one minute is called one second and is denoted by 1''.

$1^\circ = 60'$ $1' = 60''$
--------------------------------

m  $\sphericalangle$  (one rotation angle) =  $360^\circ$

m  $\sphericalangle$  (straight angle) =  $180^\circ$

m  $\sphericalangle$  (right angle) =  $90^\circ$

### 1.1.3 Circular System (Radian Measure):

In this system, the unit of measurement of an angle is a radian.

Let  $r$  be the radius of a circle with centre  $O$ . Let  $A$  and  $B$  be two points on circle such that the length of arc  $AB$  is  $r$ . Then the measure of the central angle  $AOB$  is defined as 1 radian. It is denoted by  $1^c$ .

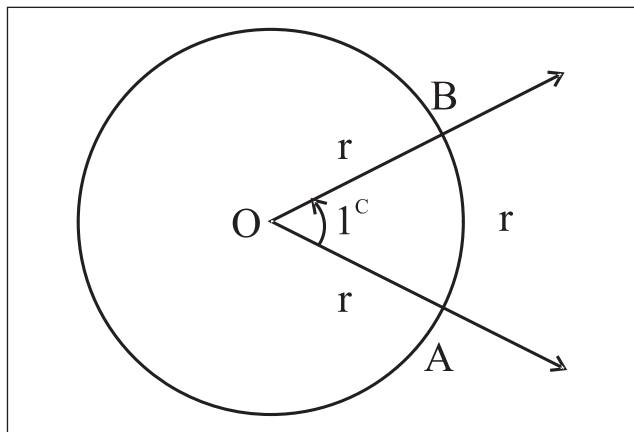

Fig. 1.12

Thus, one radian is the measure of an angle subtended at the centre of a circle by an arc whose length is equal to the radius of the circle.

### Theorem :

**The radian so defined is independent of the radius of the circle used and  $\pi^c = 180^\circ$ .**

**Proof:** Let us consider a circle with centre at  $O$  and radius  $r$ . Let  $AB$  be an arc of length  $r$ . Join  $OA$  and  $OB$ . Then  $\angle AOB = 1^c$ . Produce  $AO$  to meet the circle at  $C$ .

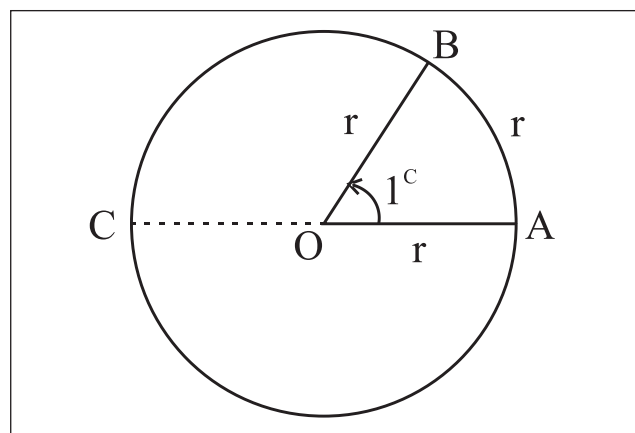

Fig. 1.13

Clearly,  $\angle AOC =$  a straight angle  
 $= 2$  right angles

Since measures of the angles at the centre of a circle are proportional to the lengths of the corresponding arcs subtending them:

$$\begin{aligned} \therefore \frac{m\angle AOB}{m\angle AOC} &= \frac{l(\text{arc}AB)}{l(\text{arc}ABC)} \\ &= \frac{r}{\frac{1}{2}(2\pi r)} = \frac{1}{\pi} \end{aligned}$$

$$\therefore m\angle AOB = \frac{1}{\pi} \cdot m\angle AOC$$

$$\therefore 1^c = m\angle AOB = \frac{(2 \text{ right angles})}{\pi},$$

a constant independent of  $r$ .

Hence one radian is well defined.

Also,  $\pi^c = 2$  right angles =  $180^\circ$ .

Hence, a radian is a constant angle and two right angles =  $180^\circ = \pi^c$

**Activity 2 :** Verify the above result by taking the circles having different radii.

Let an angle have its measure  $r$  in radian and  $\theta$  in degrees. Then its proportion with the straight angle is the same in either measure.

$$\therefore \frac{r}{\pi} = \frac{\theta}{180} \quad \therefore r^c = \theta^\circ \times \frac{\pi}{180}$$

We use this relation to convert radian measure into degree and vice-versa.

**Notes:**

- i) To convert degree measure into radian measure, multiply degree measure by  $\frac{\pi}{180}$ .
- ii) To convert radian measure into degree measure, multiply radian measure by  $\frac{180}{\pi}$ .
- iii) Taking  $\pi = 3.14$ ,

$$\begin{aligned} \text{we have } 1^\circ &= \left(\frac{180}{\pi}\right)^\circ \\ &= 57.3248^\circ \end{aligned}$$

Here fractional degree is given in decimal fraction. It can be converted into minutes and seconds as follows

$$\begin{aligned} 0.3248^\circ &= (0.3248 \times 60)' \\ &= 19.488' \\ &= 19' + (.488 \times 60)'' \\ &\approx 19' 29'' \end{aligned}$$

Thus,  $1^\circ = 57^\circ 19' 29''$

iv) In the table given below, certain degree measures are expressed in terms of radians.

Degree	15	30	45	60	90	120	180	270	360
Radian	$\frac{\pi}{12}$	$\frac{\pi}{6}$	$\frac{\pi}{4}$	$\frac{\pi}{3}$	$\frac{\pi}{2}$	$\frac{2\pi}{3}$	$\pi$	$\frac{3\pi}{2}$	$2\pi$

v) Relation between angle and time in a clock. (R is rotation.)

Min Hand	Hr Hand
1R = 360°	1R = 360°
1R = 60 min	1R = 12 Hrs
60 min = 360°	12 Hrs = 360°
1min = 6° rotation	1 Hr = 30°
	1 Hr = 60'
	60 min = 30°
	1 min = $\frac{1^\circ}{2}$

The word ‘minute’ is used for time measurement as well as 60<sup>th</sup> part of degree of angle.

vi) Please note that “minute” in time and “minute” as a fraction of degree angle are different.

**SOLVED EXAMPLES**

**Ex. 1) Convert the following degree measures in the radian measures.**

- i) 70°      ii) -120°      iii)  $\left(\frac{1}{4}\right)^\circ$

**Solution :** We know that  $\theta^\circ = \left(\theta \times \frac{\pi}{180}\right)^c$

$$\text{i) } 70^\circ = \left(70 \times \frac{\pi}{180}\right)^c$$

$$\therefore 70^\circ = \left(\frac{7\pi}{18}\right)^c$$

$$\text{ii) } -120^\circ = -\left(120 \times \frac{\pi}{180}\right)^c$$

$$\therefore -120^\circ = -\left(\frac{2\pi}{3}\right)^c$$

$$\text{iii) } \left(\frac{1}{4}\right)^\circ = \left(\frac{1}{4} \times \frac{\pi}{180}\right)^c$$

$$\therefore \left(\frac{1}{4}\right)^\circ = \left(\frac{\pi}{720}\right)^c$$

**Ex. 2) Convert the following radian measures in the degree measures.**

i)  $\left(\frac{7\pi}{3}\right)^c$     ii)  $\left(\frac{-\pi}{18}\right)^c$     iii)  $\left(\frac{4}{7}\right)^c$

**Solution :** We know that  $\theta^c = \left(\theta \times \frac{180}{\pi}\right)^\circ$

i)  $\left(\frac{7\pi}{3}\right)^c = \left(\frac{7\pi}{3} \times \frac{180}{\pi}\right)^\circ$   
 $\therefore \left(\frac{7\pi}{3}\right)^c = 420^\circ$

ii)  $\left(\frac{-\pi}{18}\right)^c = \left(\frac{-\pi}{18} \times \frac{180}{\pi}\right)^\circ$   
 $\therefore \left(\frac{-\pi}{18}\right)^c = -10^\circ$

Note that,

$180^\circ = \pi^c$

Hence,

$1^\circ = \left(\frac{\pi}{180}\right)^c, \quad 1^c = \left(\frac{180}{\pi}\right)^\circ$

iii)  $\left(\frac{4}{7}\right)^c = \left(\frac{4}{7} \times \frac{180}{\pi}\right)^\circ$   
 $\therefore \left(\frac{4}{7}\right)^c = \left(\frac{720}{7\pi}\right)^\circ = \left(\frac{360}{11}\right)^\circ$

**Ex. 3) Express the following angles in degrees, minutes and seconds.**

i)  $74.87^\circ$     ii)  $-30.6947^\circ$

**Solution:**

i)  $74.87^\circ = 74^\circ + 0.87^\circ$   
 $= 74^\circ + (0.87 \times 60)'$   
 $= 74^\circ + (52.2)'$   
 $= 74^\circ 52' + 0.2'$

$= 74^\circ 52' + (0.2 \times 60)''$   
 $= 74^\circ 52' 12''$

ii)  $-30.6947^\circ = -[30^\circ + 0.6947^\circ]$   
 $= -[30^\circ + (0.6947 \times 60)']$   
 $= -[30^\circ + 41.682']$   
 $= -[30^\circ + 41'(0.682 \times 60)'']$   
 $= -[30^\circ 41' 40.92'']$   
 $= -30^\circ 41' 41''$  approximately

**Ex. 4) The measures of the angles of the triangle are in A. P. The smallest angle is  $40^\circ$ . Find the angles of the triangle in degree and in radians.**

**Solution :** Let the angles of the triangle be  $a - d$ ,

$a, a + d$  in degrees.

$\therefore a - d + a + a + d = 180^\circ$

$\therefore 3a = 180^\circ$

$\therefore a = 60^\circ$

Also, smallest angle

$= 40^\circ$

$\therefore a - d = 40^\circ$

$\therefore 60^\circ - d = 40^\circ$

$\therefore 60^\circ - 40^\circ = d$

$\therefore d = 20^\circ$

Now,  $a + d = 60^\circ + 20^\circ = 80^\circ$

Hence the angles are  $40^\circ, 60^\circ, 80^\circ$

if they are  $\theta_1^c, \theta_2^c, \theta_3^c, 40^\circ = \theta_1^c$ , then  $\frac{40}{180} = \frac{\theta_1}{\pi}$  so that  $\theta_1 = \frac{2\pi^c}{9}$   $\theta_2 = \frac{60}{180} \times \pi = \frac{\pi^c}{3}$   
 $= \frac{80}{180} \pi = \frac{4}{9} \pi^c$

Hence the angles are  $\frac{2\pi^c}{9}, \frac{\pi^c}{3}$  and  $\frac{4\pi^c}{9}$ .

The angles of a triangle in degrees are  $40^\circ$ ,  $60^\circ$  and  $80^\circ$  and in radians  $\frac{2\pi^c}{9}$ ,  $\frac{\pi^c}{3}$  and  $\frac{4\pi^c}{9}$

**Ex. 5)** The difference between two acute angles of a right angled triangle is  $\frac{7\pi^c}{30}$ .

Find the angles of the triangle in degrees.

**Solution :** Let  $x$  and  $y$  be the acute angles of a triangle in degrees.

$$\begin{aligned} \text{Here, } x - y &= \frac{7\pi^c}{30} = \left(\frac{7\pi}{30} \times \frac{180}{\pi}\right)^\circ \\ &= 42^\circ \end{aligned}$$

$$\therefore x - y = 42^\circ \dots\dots\dots \text{(I)}$$

The triangle is right angled.

$$\therefore x + y = 90^\circ \dots\dots\dots \text{(II)}$$

adding, (I) + (II),

$$\text{we get } x - y + x + y = 42^\circ + 90^\circ$$

$$\therefore 2x = 132^\circ$$

$$\therefore x = 66^\circ$$

Put in (I)

$$66^\circ - y = 42^\circ \quad \therefore 66^\circ - 42^\circ = y$$

$$\therefore y = 24^\circ$$

$\therefore$  The angles of a triangle are  $66^\circ$ ,  $90^\circ$  and  $24^\circ$ .

**Ex. 6)** One angle of a quadrilateral is  $\frac{2\pi}{9}$

radian and the measures of the other three angles are in the ratio 3:5:8, find their measures in degree.

**Solution :** The sum of angles of a quadrilateral is  $360^\circ$ .

$$\begin{aligned} \text{One of the angles is given to be } \left(\frac{2\pi}{9}\right)^\circ &= \\ \left(\frac{2\pi}{9} \times \frac{180}{\pi}\right)^\circ &= 40^\circ \end{aligned}$$

$\therefore$  Sum of the remaining three angles is  $360^\circ - 40^\circ = 320^\circ$

Since these three angles are in the ratio 3:5:8.

$\therefore$  Degree measures of these angles are  $3k$ ,  $5k$ ,  $8k$ , where  $k$  is constant.

$$\therefore 3k + 5k + 8k = 320^\circ$$

$$\therefore 16k = 320^\circ$$

$$\therefore k = 20^\circ$$

$\therefore$  The measures of three angles are

$$(3k)^\circ = (3 \times 20)^\circ = 60^\circ$$

$$(5k)^\circ = (5 \times 20)^\circ = 100^\circ$$

and  $(8k)^\circ = (8 \times 20)^\circ = 160^\circ$

**Ex. 7)** Find the number of sides of a regular polygon if each of its interior angle is

$$\left(\frac{4\pi}{5}\right)^\circ.$$

**Solution:**

Let the number of sides be 'n'.

$$\begin{aligned} \text{each interior angle} &= \frac{4\pi^c}{5} \\ &= \left(\frac{4\pi^c}{5} \times \frac{180}{\pi}\right)^\circ = 144^\circ \end{aligned}$$

$$\text{Exterior angle} = 180^\circ - 144^\circ = 36^\circ$$

$$\therefore \left(\frac{360}{n}\right)^\circ = 36^\circ$$

$$\therefore n = \frac{360}{36}$$

$$\therefore n = 10$$

$\therefore$  number of sides of the regular polygon is 10.

**Ex. 8)** Find the angle between hour hand and minute hand of a clock at

- i) Quarter past five
- ii) Quarter to twelve

**Solution :**

- 1) When a hour hand moves from one clock mark to the next one, it turns through an angle of  $\frac{360^\circ}{12} = 30^\circ$ .

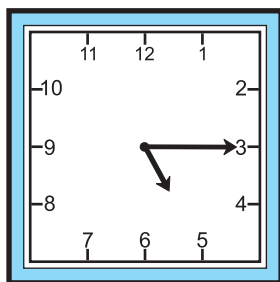

Fig. 1.14

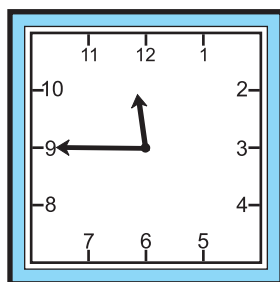

Fig. 1.15

At quarter past 5, minute hand is pointing to 3. Hour hand has gone past 5. So the angle between them is more than  $60^\circ$ . In one minute hour hand turns through  $\frac{1^\circ}{2}$  hence in 15 minutes it has turned through  $\left(\frac{15}{2}\right)^\circ = 7.5^\circ$ . Thus the angle between the hands is equal to  $60^\circ + 7.5^\circ = 67.5^\circ$ .

ii) At quarter to twelve, minute hand is pointing to 9, hour hand is between 11 and 12 though it is nearer 12. It will take 15 minutes i.e.  $7.5^\circ$  to reach 12.

$\therefore$  the angle between the hands is equal to  $90^\circ - 7.5^\circ = 82.5^\circ$ .

**Note:**

In degrees	$0^\circ$	$30^\circ$	$45^\circ$	$60^\circ$	$90^\circ$	$180^\circ$	$270^\circ$	360
In radians	$0^c$	$\frac{\pi^c}{6}$	$\frac{\pi^c}{4}$	$\frac{\pi}{3}$	$\frac{\pi}{2}$	$\pi^c$	$\frac{\pi^c}{4}$	$2\pi^c$

**EXERCISE 1.1**

Q.1 A) Determine which of the following pairs of angles are co-terminal.

- i)  $210^\circ, -150^\circ$     ii)  $360^\circ, -30^\circ$   
 iii)  $-180^\circ, 540^\circ$     iv)  $-405^\circ, 675^\circ$   
 v)  $860^\circ, 580^\circ$     vi)  $900^\circ, -900^\circ$

B) Draw the angles of the following measures and determine their quadrants.

- i)  $-140^\circ$     ii)  $250^\circ$     iii)  $420^\circ$     iv)  $750^\circ$   
 v)  $945^\circ$     vi)  $1120^\circ$     vii)  $-80^\circ$     viii)  $-330^\circ$   
 ix)  $-500^\circ$     x)  $-820^\circ$

Q.2 Convert the following angles in to radian.

- i)  $85^\circ$     ii)  $250^\circ$   
 iii)  $-132^\circ$     iv)  $65^\circ 30'$   
 v)  $75^\circ 30'$     vi)  $40^\circ 48'$

Q.3 Convert the following angles in degree.

- i)  $\frac{7\pi^c}{12}$     ii)  $\frac{-5\pi^c}{3}$     iii)  $5^c$   
 iv)  $\frac{11\pi^c}{18}$     v)  $\left(\frac{-1}{4}\right)^c$

Q.4 Express the following angles in degree, minute and second.

- i)  $(183.7)^\circ$     ii)  $(245.33)^\circ$     iii)  $\left(\frac{1}{5}\right)^c$

Q.5 In  $\Delta ABC$ , if  $m\angle A = \frac{7\pi^c}{36}$ ,

$m\angle B = 120^\circ$ , find  $m\angle C$  in degree and radian.

Q.6 Two angles of a triangle are  $\frac{5\pi^c}{9}$  and  $\frac{5\pi^c}{18}$ . Find the degree and radian measure

of third angle.

Q.7 In a right angled triangle, the acute angles are in the ratio 4:5. Find the angles of the triangle in degree and radian.

Q.8 The sum of two angles is  $5\pi^c$  and their difference is  $60^\circ$ . Find their measures in degree.

Q.9 The measures of the angles of a triangle are in the ratio 3:7:8. Find their measures in degree and radian.

**Q.10** The measures of the angles of a triangle are in A.P. and the greatest is 5 times the smallest (least). Find the angles in degree and radian.

**Q.11** In a cyclic quadrilateral two adjacent angles are  $40^\circ$  and  $\frac{\pi^c}{3}$ . Find the angles of the quadrilateral in degree.

**Q.12** One angle of a quadrilateral has measure  $\frac{2\pi^c}{5}$  and the measures of other three angles are in the ratio 2:3:4. Find their measures in degree and radian.

**Q.13** Find the degree and radian measure of exterior and interior angle of a regular  
 i) Pentagon                      ii) Hexagon  
 iii) Septagon                  iv) Octagon

**Q.14** Find the angle between hour-hand and minute-hand in a clock at  
 i) ten past eleven  
 ii) twenty past seven  
 iii) thirty five past one  
 iv) quarter to six  
 v) 2:20                      vi) 10:10

**Let's Understand**

**1.2 ARC LENGTH AND AREA OF A SECTOR:-**

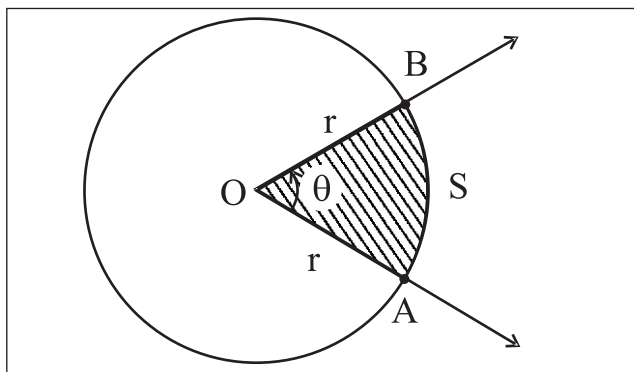

**Fig. 1.16**

The area A of a sector is in the proportion of its central angle  $\theta$ .

If the central angle  $\theta$  is in radian,

$$\frac{\theta}{2\pi} = \frac{A}{\text{Area of the circle}}$$

$$\therefore \frac{\theta}{2\pi} = \frac{A}{\pi r^2}$$

$$\therefore A = \frac{\theta r^2}{2} = \frac{1}{2} r^2 \theta$$

The arc length S of a sector is in the proportion of its central angle. If the central angle is  $\theta$  radians.

$$\frac{\theta}{2\pi} = \frac{S}{\text{circumference of the circle}}$$

$$\therefore \frac{\theta}{2\pi} = \frac{S}{2\pi r}$$

$$\therefore S = r\theta.$$

**SOLVED EXAMPLES**

**Ex. 1)** The diameter of a circle is 14 cm. Find the length of the arc, subtending an angle of  $54^\circ$  at the centre.

**Solution :** Here diameter = 14 cm

$$\therefore \text{Radius} = r = 7 \text{ cm}$$

$$\theta^c = \left(54 \times \frac{\pi}{180}\right)^c = \left(\frac{3\pi}{10}\right)^c$$

To find s, we know that  $s = r\theta$

$$= 7 \times \frac{3\pi}{10} = \frac{7 \times 3}{10} \times \frac{22}{7} = \frac{66}{10}$$

$$\therefore \text{arc length} = 6.6 \text{ cm}$$

**Ex. 2)** In a circle of radius 12 cms, an arc PQ subtends an angle of  $30^\circ$  at the centre. Find the area between the arc PQ and chord PQ.

**Solution :**

$$r = 12\text{cms,}$$

$$\theta^{\circ} = 30^{\circ}$$

$$= \left(30 \times \frac{\pi}{180}\right)^{\circ}$$

$$\theta = \frac{\pi}{6}$$

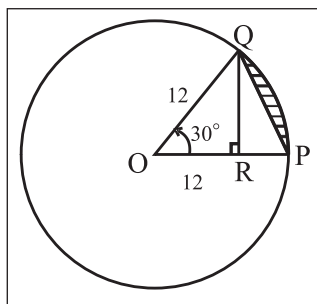

**Fig. 1.17**

$$\begin{aligned} \text{Area of sector OPQ} &= \frac{1}{2}r^2\theta \\ &= \frac{1}{2} \times 12 \times 12 \times \frac{\pi}{6} \\ &= 12\pi \text{ sq.cm. .... (1)} \end{aligned}$$

$$\text{Draw } QR \perp OP, \quad \therefore \sin 30^{\circ} = \frac{QR}{12}$$

$$\begin{aligned} \therefore QR &= 12 \times \frac{1}{2} = 6 \text{ cms} \\ &= \text{Height of } \Delta \text{ OPQ} \end{aligned}$$

$$\begin{aligned} \text{Area of } \Delta \text{ OPQ} &= \frac{1}{2} \times \text{base} \times \text{height} \\ &= \frac{1}{2} \times 12 \times 6 \\ &= 36 \text{ sq.cm .....(2)} \end{aligned}$$

By (1) and (2),

$$\begin{aligned} \text{Required Area} &= A(\text{Sector OPQ}) - A(\Delta \text{OPQ}) \\ &= (12\pi - 36)\text{sq.cm.} \\ &= 12(\pi - 3)\text{sq.cm} \end{aligned}$$

**Ex. 3)** The area of a circle is  $225\pi$  sq. cm. Find the length of its arc subtending an angle of  $120^{\circ}$  at the centre. Also find the area of the corresponding sector.

**Solution :** Let 'r' be the radius of a circle whose

area is  $225\pi$  sq. cm.

$$\therefore \pi r^2 = 225\pi$$

$$\therefore r^2 = 225$$

$$\therefore r = 15 \text{ cm.}$$

$$\theta^{\circ} = 120^{\circ} = \left(120 \times \frac{\pi}{180}\right)^{\circ} = \frac{2\pi}{3}$$

To find s and A.

$$\text{We know that } s = r\theta \text{ and } A = \frac{1}{2}r^2\theta$$

$$\therefore s = 15 \times \frac{2\pi}{3} = 10\pi \text{ and}$$

$$A = \frac{1}{2} \times 15 \times 15 \times \frac{2\pi}{3} = 75\pi$$

$$\therefore s = 10\pi \text{ cm and } A = 75\pi \text{ sq.cm.}$$

**Ex. 4)** The perimeter of a sector is equal to half of the circumference of a circle. Find the measure of the angle of the sector at the centre in radian.

**Solution :** Let r be the radius of a circle.

Perimeter of a sector = half of the circumference

$$\therefore l(\text{OA}) + l(\text{OB}) + l(\text{arc APB}) = \frac{1}{2}(2\pi r)$$

$$\begin{aligned} \therefore r + r + r\theta \\ &= \pi r \end{aligned}$$

$$2r + r\theta = \pi r$$

$$\therefore 2 + \theta = \pi$$

$$\therefore \theta = (\pi - 2)^{\circ}$$

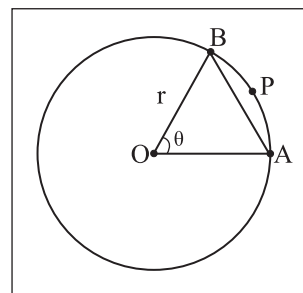

**Fig. 1.18**

**Ex. 5)** A pendulum of length 21cm oscillates through an angle of  $36^{\circ}$ . Find the length of its path.

**Solution :** Here r = 21 cm

$$\theta = 36^{\circ} = \left(36 \times \frac{\pi}{180}\right)^{\circ} = \frac{\pi}{5}$$

Length of its path =

$$l(\text{arc AXB})$$

$$= s = r\theta$$

$$= 21 \times \frac{\pi}{5}$$

$$= \frac{21}{5} \times \frac{22}{7} = \frac{66}{5}$$

$$\text{Length of path} = 13.2 \text{ cm}$$

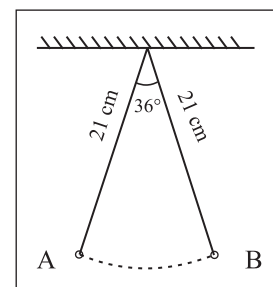
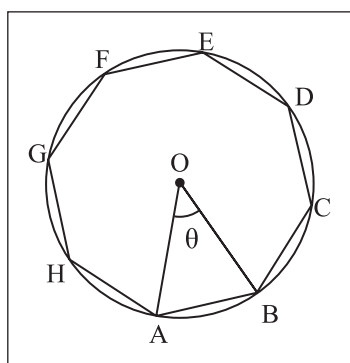

**Fig. 1.19**

**Ex. 6)** ABCDEFGH is a regular octagon inscribed in a circle of radius 9cm. Find the length of minor arc AB.

**Solution :** Here  $r = 9\text{cm}$

$$\theta = \frac{360^\circ}{8} = 45^\circ = \frac{\pi^c}{4}$$



**Fig. 1.20**

$$\begin{aligned} l(\text{minor arc AB}) &= S \\ &= r\theta \\ &= 9\left(\frac{\pi}{4}\right)\text{cm} \end{aligned}$$

### EXERCISE 1.2

- (1) Find the length of an arc of a circle which subtends an angle of  $108^\circ$  at the centre, if the radius of the circle is 15 cm.
- (2) The radius of a circle is 9 cm. Find the length of an arc of this circle which cuts off a chord of length, equal to length of radius.
- (3) Find the angle in degree subtended at the centre of a circle by an arc whose length is 15 cm, if the radius of the circle is 25 cm.
- (4) A pendulum of length 14 cm oscillates through an angle of  $18^\circ$ . Find the length of its path.
- (5) Two arcs of the same lengths subtend angles of  $60^\circ$  and  $75^\circ$  at the centres of two circles. What is the ratio of radii of two circles ?
- (6) The area of a circle is  $25\pi$  sq.cm. Find the length of its arc subtending an angle of  $144^\circ$  at the centre. Also find the area of the corresponding sector.
- (7) OAB is a sector of the circle having centre at O and radius 12 cm. If  $m\angle AOB = 45^\circ$ , find the difference between the area of sector OAB and sector AOB.
- (8) OPQ is the sector of a circle having centre at O and radius 15 cm. If  $m\angle POQ = 30^\circ$ , find the area enclosed by arc PQ and chord PQ.
- (9) The perimeter of a sector of the circle of area  $25\pi$  sq.cm is 20 cm. Find the area of sector.
- (10) The perimeter of the sector of the circle of area  $64\pi$  sq.cm is 56 cm. Find the area of the sector.



### Let's Remember

- If an angle is  $r$  radians and also  $\theta$  degrees then  $\frac{r}{\pi} = \frac{\theta}{180^\circ}$
- $\theta^\circ = \left(\theta \times \frac{\pi}{180}\right)^c$ ,  $1^\circ = (0.01745)^c$
- $\theta^c = \left(\theta \times \frac{180}{\pi}\right)^\circ$ ,  $1^c = 57^\circ 17' 48''$
- Arc length =  $s = r\theta$ .  $\theta$  is in radians.
- Area of a sector  $A = \frac{1}{2}r^2\theta$ , where  $\theta$  is in radians.
- Two angles are co-terminal if and only if the difference of their measures is an integral multiple of 360.
- Exterior angle of a regular polygon of  $n$  sides =  $\left(\frac{360}{n}\right)^\circ$
- In one hour, hour's hand covers  $30^\circ$  and a minutes hand covers  $360^\circ$ .

- In 1 minute, hour hand turns through  $\left(\frac{1}{2}\right)^\circ$  and minute hand turns through  $6^\circ$ .
- 7) If the angles of a triangle are in the ratio 1:2:3, then the smallest angle in radian is  
A)  $\frac{\pi}{3}$     B)  $\frac{\pi}{6}$     C)  $\frac{\pi}{2}$     D)  $\frac{\pi}{9}$

**MISCELLANEOUS EXERCISE - 1**

**I Select the correct option from the given alternatives.**

- 1)  $\left(\frac{22\pi}{15}\right)^\circ$  is equal to  
A)  $246^\circ$     B)  $264^\circ$     C)  $224^\circ$     D)  $426^\circ$
- 2)  $156^\circ$  is equal to  
A)  $\left(\frac{17\pi}{15}\right)^\circ$     B)  $\left(\frac{13\pi}{15}\right)^\circ$     C)  $\left(\frac{11\pi}{15}\right)^\circ$   
D)  $\left(\frac{7\pi}{15}\right)^\circ$
- 3) A horse is tied to a post by a rope. If the horse moves along a circular path, always keeping the rope tight and describes 88 meters when it traces the angle of  $72^\circ$  at the centre, then the length of the rope is  
A) 70 m.    B) 55 m.    C) 40 m.    D) 35 m.
- 4) A pendulum of 14cms long oscillates through an angle of  $12^\circ$ , then the angle of the path described by its extrimities is  
A)  $\frac{13\pi}{14}$     B)  $\frac{14\pi}{13}$     C)  $\frac{15\pi}{14}$     D)  $\frac{14\pi}{15}$
- 5) Angle between hand's of a clock when it shows the time 9.45 is  
A)  $(7.5)^\circ$     B)  $(12.5)^\circ$     C)  $(17.5)^\circ$     D)  $(22.5)^\circ$
- 6) 20 meters of wire is available for fancing off a flower-bed in the form of a circular sector of radius 5 meters, then the maximum area (in sq. m.) of the flower-bed is  
A) 15    B) 20    C) 25    D) 30
- 8) A semicircle is divided into two sectors whose angles are in the ratio 4:5. Find the ratio of their areas?  
A) 5:1    B) 4:5    C) 5:4    D) 3:4
- 9) Find the measure of the angle between hour-hand and the minute hand of a clock at twenty minutes past two.  
A)  $50^\circ$     B)  $60^\circ$     C)  $54^\circ$     D)  $65^\circ$
- 10) The central angle of a sector of circle of area  $9\pi$  sq.cm is  $60^\circ$ , the perimeter of the sector is  
A)  $\pi$     B)  $3+\pi$     C)  $6+\pi$     D) 6

**II Answer the following.**

- 1) Find the number of sides of a regular polygon if each of its interior angle is  $\frac{3\pi}{4}$ .
- 2) Two circles, each of radius 7 cm, intersect each other. The distance between their centres is  $7\sqrt{2}$  cm. Find the area common to both the circles.
- 3)  $\Delta$  PQR is an equilateral triangle with side 18 cm. A circle is drawn on the segment QR as diameter. Find the length of the arc of this circle within the triangle.
- 4) Find the radius of the circle in which central angle of  $60^\circ$  intercepts an arc of length 37.4 cm.

- 5) A wire of length 10 cm is bent so as to form an arc of a circle of radius 4 cm. What is the angle subtended at the centre in degree ?
- 6) If two arcs of the same length in two circles subtend angles  $65^\circ$  and  $110^\circ$  at the centre. Find the ratio of their radii.
- 7) The area of a circle is  $81\pi$  sq.cm. Find the length of the arc subtending an angle of  $300^\circ$  at the centre and also the area of the corresponding sector.
- 8) Show that minute hand of a clock gains  $5^\circ 30''$  on the hour hand in one minute.
- 9) A train is running on a circular track of radius 1 km at the rate of 36 km per hour. Find the angle to the nearest minute, through which it will turn in 30 seconds.
- 10) In a circle of diameter 40 cm, the length of a chord is 20 cm. Find the length of minor arc of the chord.
- 11) The angles of a quadrilateral are in A.P. and the greatest angle is double the least. Find angles of the quadrilateral in radian.



# 2 Trigonometry - 1

## Let's Study

- Trigonometric functions with the help of unit circle
- Extensions of trigonometric functions to any angle
- Range and Signs of trigonometric functions in different quadrants
- Fundamental Identities and Periodicity of trigonometric functions
- Domain, Range and Graph of each trigonometric function
- Polar Co-ordinates

### 2.1 Introduction

Trigonometry is a branch of Mathematics that deals with the relation between sides and angles of triangles. The word 'trigonometry' is derived from the Greek words 'trigonon' and 'metron'. It means measuring the sides of triangles. Greek Mathematicians used trigonometric ratios to determine unknown distances. The Egyptians used a primitive form of trigonometry for building pyramids in the second millennium BC. Greek astronomer Hipparches (190-120 BC) formulated the general principles of trigonometry and he is known as the founder of the trigonometry.

We are familiar with trigonometric ratios of acute angles in a right angled triangle. We have introduced the concept of directed angle having any measure, in the previous chapter. We



shall now extend the definitions of trigonometric ratios to angles of any measure in terms of co-ordinates of points on the standard circle.

## Let's Recall

We have studied that, in a right angled triangle if measure of an acute angle is ' $\theta$ ', then

$$\sin\theta = \frac{\text{opposite side}}{\text{hypoteneous}}, \quad \cos\theta = \frac{\text{adjacent side}}{\text{hypoteneous}},$$

$$\tan\theta = \frac{\text{opposite side}}{\text{adjacent side}} \quad (\text{see fig 2.1 (a)})$$

$$\text{Also, } \operatorname{cosec}\theta = \frac{1}{\sin\theta}, \quad \operatorname{sec}\theta = \frac{1}{\cos\theta},$$

$$\operatorname{cot}\theta = \frac{1}{\tan\theta}.$$

## Let's Learn

### 2.1.1 Trigonometric functions with the help of a circle:

#### Trigonometric ratios of any angle

We have studied that in right angled  $\Delta ABC$ , ' $\theta$ ' is an acute angle

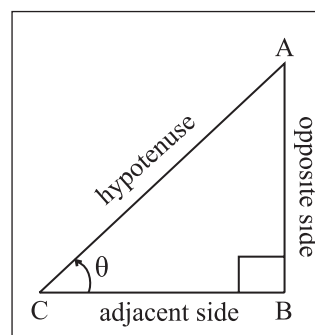

Fig. 2.1(a)

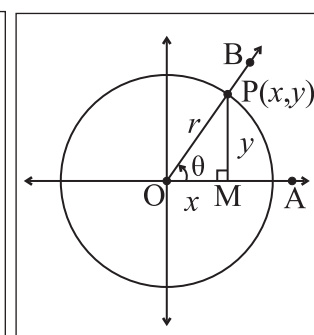

Fig. 2.1(b)

$$\cos\theta = \frac{\text{adjacent side}}{\text{hypoteneous}} = \frac{BC}{AC}$$

$$\sin\theta = \frac{\text{opposite side}}{\text{hypoteneous}} = \frac{AB}{AC}$$

We will now extend this definition to any angle  $\theta$ , consider  $\theta$  as directed angle,

Let ' $\theta$ ' be an acute angle. [See fig. 2.1 (b)]

consider a circle of radius ' $r$ ' with centre at origin ' $O$ ' of the co-ordinate system.

OA is the initial ray of angle  $\theta$ ,

OB is its terminal ray.

$P(x,y)$  is a point on the circle and on ray OB.

Draw  $PM \perp$  to OA.

$\therefore OM = x$ ,  $PM = y$  and  $OP = r$ .

using  $\Delta PMO$  we get,

$$\cos\theta = \frac{OM}{OP} = \frac{x}{r}, \quad \sin\theta = \frac{PM}{OP} = \frac{y}{r},$$

then we define

$$\cos\theta = \frac{x}{r} = \frac{x - \text{co-ordinate of P}}{\text{Distance of P from origin}}$$

$$\sin\theta = \frac{y}{r} = \frac{y - \text{co-ordinate of P}}{\text{Distance of P from origin}}$$

$$\text{and } r^2 = x^2 + y^2$$

$$\text{Hence, } \cos^2\theta + \sin^2\theta = 1$$

For every angle ' $\theta$ ', there is corresponding unique point  $P(x,y)$  on the circle, which is on the terminal ray of ' $\theta$ ', so trigonometric ratio's of  $\theta$  are also trigonometric functions of ' $\theta$ '.

**Note that :** 1) Trigonometric ratios / functions are independent of radius ' $r$ '.

2) Trigonometric ratios of coterminal angles are same.

We consider the circle with center at origin and radius  $r$ . Let  $P(x,y)$  be the point on the circle with  $m\angle MOP = \theta$

Since P lies on the circle,  $OP = r$

$$\therefore \sqrt{x^2 + y^2} = r$$

The definitions of  $\sin\theta$ ,  $\cos\theta$  and  $\tan\theta$  can now be extended for  $\theta = 0^\circ$  and  $90^\circ \leq \theta \leq 360^\circ$ . We will also define  $\sec\theta$ ,  $\text{cosec}\theta$  and  $\cot\theta$ .

Every angle  $\theta$ ,  $0^\circ \leq \theta \leq 360^\circ$ , determines a unique point P on the circle so that OP makes angle  $\theta$  with X-axis.

The pair  $(x,y)$  of co-ordinates of P is uniquely determined by  $\theta$ . Thus  $x = r\cos\theta$ ,  $y = r\sin\theta$  are functions of  $\theta$ .

**Note :**

- 1) If P  $(x, y)$  lies on the unit circle then  $\cos\theta = x$  and  $\sin\theta = y$ .  $\therefore P(x, y) \equiv P(\cos\theta, \sin\theta)$
- 2) The trigonometric functions do not depend on the position of the point on the terminal arm but they depend on measure of the angle.

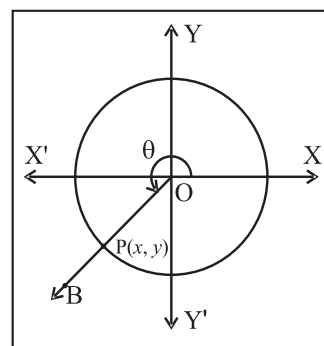

Fig. 2.2

Point  $P(x,y)$  is on the circle of radius  $r$  and  $Q(x',y')$  is on the unit circle.

Considering results on similar triangles.

$$\sin\theta = \frac{y}{r} = \frac{y'}{1},$$

$$\therefore y = r \sin\theta$$

$$y' = \sin\theta \text{ and}$$

$$\cos\theta = \frac{x}{r} = \frac{x'}{1}, \quad x = r \cos\theta \quad x' = \cos\theta$$

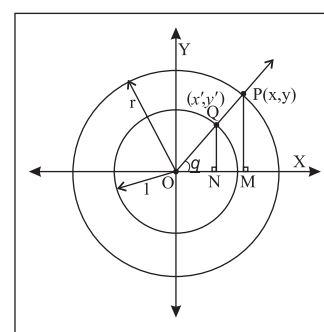

Fig. 2.3

### 2.1.2 Signs of trigonometric functions in different quadrants :

Trigonometric functions have positive or negative values depending on the quadrant in which the point  $P(x, y)$  lies. Let us find signs of trigonometric ratios in different quadrants. If the terminal arm of an angle  $\theta$  intersects the unit circle in the point  $P(x, y)$ , then  $\cos\theta = x$ .

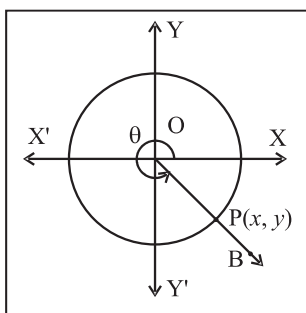

Fig. 2.4

$\sin\theta = y$  and  $\tan\theta = \frac{y}{x}$ . The values of  $x$  and  $y$  are positive or negative depending on the quadrant in which  $P$  lies.

- 1) In the first quadrant ( $0 < \theta < \frac{\pi}{2}$ ), both  $x$  and  $y$  are positive, hence

$\cos\theta = x$  is positive

$\sin\theta = y$  is positive

$\tan\theta = \frac{y}{x}$  is positive

Hence all trigonometric functions of  $\theta$  are positive in the first quadrant.

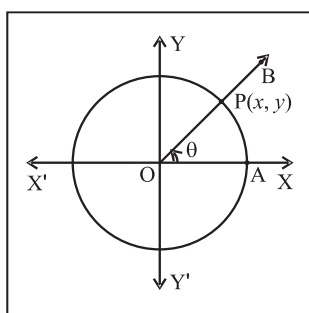

Fig. 2.5

- 2) In the second quadrant ( $\frac{\pi}{2} < \theta < \pi$ ),  $y$  is positive and  $x$  is negative, hence

$\cos\theta = x$  is negative

$\sin\theta = y$  is positive

$\tan\theta = \frac{y}{x}$  is negative

Hence only  $\sin\theta$  is positive,  $\cos\theta$  and  $\tan\theta$  are negative for  $\theta$  in the second quadrant.

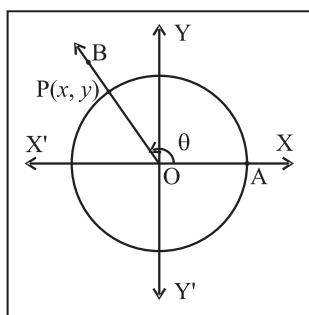

Fig. 2.6

- 3) In the third quadrant ( $\pi < \theta < \frac{3\pi}{2}$ ), both  $x$  and  $y$  are negative, hence

$\cos\theta = x$  is negative

$\sin\theta = y$  is negative

$\tan\theta = \frac{y}{x}$  is positive

Hence only  $\tan\theta$  is positive and  $\sin\theta$  and  $\cos\theta$  are negative for  $\theta$  in the third quadrant.

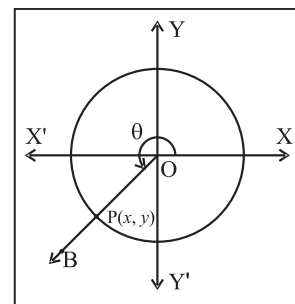

Fig. 2.7

- 4) In the fourth quadrant ( $\frac{3\pi}{2} < \theta < 2\pi$ ),  $x$  is positive and  $y$  is negative, hence

$\sin\theta = y$  is negative

$\cos\theta = x$  is positive

$\tan\theta = \frac{y}{x}$  is negative

Hence only  $\cos\theta$  is positive;  $\sin\theta$  and  $\tan\theta$  are negative for  $\theta$  in the fourth quadrant.

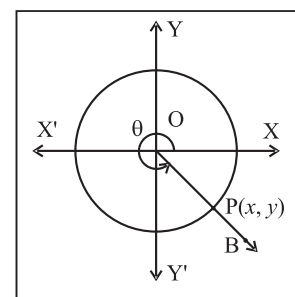

Fig. 2.8

You can check  $\sin\theta$  &  $\operatorname{cosec}\theta$ , have the same sign,  $\cos\theta$  &  $\operatorname{sec}\theta$  have the same sign and similarly  $\tan\theta$  &  $\operatorname{cot}\theta$  have the same sign, when they exist.

**Remark:** Signs of  $\operatorname{cosec}\theta$ ,  $\operatorname{sec}\theta$  and  $\operatorname{cot}\theta$  are same as signs of  $\sin\theta$ ,  $\cos\theta$  and  $\tan\theta$  respectively.

**2.1.3 Range of  $\cos\theta$  and  $\sin\theta$  :**  $P(x, y)$  is point on the unit circle.  $m\angle AOB = \theta$ .  $OP = 1$

$$\therefore x^2 + y^2 = 1$$

$$\therefore x^2 \leq 1 \text{ and } y^2 \leq 1$$

$$\therefore -1 \leq x \leq 1 \text{ and } -1 \leq y \leq 1$$

$$\therefore -1 \leq \cos\theta \leq 1 \text{ and } -1 \leq \sin\theta \leq 1$$

**SOLVED EXAMPLE**

**Ex.1.** Find the signs of the following :

- i)  $\sin 300^\circ$  ii)  $\cos 400^\circ$  iii)  $\cot (-206^\circ)$

**Solution:**

(For given  $\theta$ , we need to find coterminal angle which lies between  $0^\circ$  and  $360^\circ$ )

- i)  $270^\circ < 300^\circ < 360^\circ$   
 $\therefore 300^\circ$  angle lies in the fourth quadrant.  
 $\therefore \sin 300^\circ$  is negative.
- ii)  $400^\circ = 360^\circ + 40^\circ$   
 $\therefore 400^\circ$  and  $40^\circ$  are co-terminal angles (hence their trigonometric ratios are same)  
 Since  $40^\circ$  lies in the first quadrant,  $400^\circ$  also lies in the first quadrant.  
 $\therefore \cos 400^\circ$  is positive.
- iii)  $-206^\circ = -360^\circ + 154^\circ$   
 $154^\circ$  and  $-206^\circ$  are coterminal angles. Since  $154^\circ$  lies in the second quadrant, therefore  $\cot (-206^\circ)$  is negative.

**2.1.4 Trigonometric Functions of specific angles**

**1) Angle of measure  $0^\circ$  :** Let  $m\angle XOP = 0^\circ$ . Its terminal arm intersects unit circle in  $P(1,0)$ . Hence  $x = 1$  and  $y = 0$ .

We have defined,

$\sin\theta = y, \cos\theta = x$

and  $\tan\theta = \frac{y}{x}$

$\therefore \sin 0^\circ = 0, \cos 0^\circ = 1,$

and  $\tan 0^\circ = \frac{0}{1} = 0$

$\operatorname{cosec} 0^\circ$  is not defined as  $y = 0$ ,  $\sec 0^\circ = 1$  and  $\cot 0^\circ$  is not defined as  $y = 0$

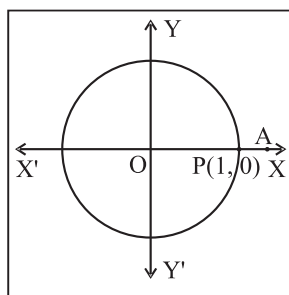

**Fig. 2.9**

**2) Angle of measure  $90^\circ$  or  $\left(\frac{\pi}{2}\right)^c$  :** Let  $m\angle XOP = 90^\circ$ . Its terminal arm intersects unit circle in  $P(0,1)$ .

Hence  $x = 0$  and  $y = 1$

$\therefore \sin 90^\circ = y = 1$

$\cos 90^\circ = x = 0$

$\tan 90^\circ$  is not defined as  $\cos 90^\circ = 0$

$\operatorname{cosec} 90^\circ = \frac{1}{y} = \frac{1}{1} = 1$

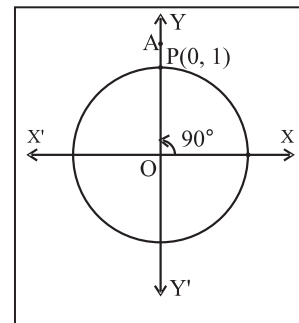

**Fig. 2.10**

$\sec 90^\circ$  is not defined as  $x = 0$

$\cot 90^\circ = \frac{x}{y} = \frac{0}{1} = 0$

**(Activity) :**

Find trigonometric functions of angles  $180^\circ, 270^\circ$ .

**3) Angle of measure  $360^\circ$  or  $(2\pi)^c$  :** Since  $360^\circ$  and  $0^\circ$  are co-terminal angles, trigonometric functions of  $360^\circ$  are same as those of  $0^\circ$ .

**4) Angle of measure  $120^\circ$  or  $\left(\frac{2\pi}{3}\right)^c$  :**

Let  $m\angle XOP = 120^\circ$ . Its terminal arm intersects unit circle in  $P(x, y)$ .

Draw  $PQ$  perpendicular to the  $X$ -axis

$\therefore \Delta OPQ$  is  $30^\circ - 60^\circ - 90^\circ$  triangle.

$\therefore OQ = \frac{1}{2}$  and  $PQ = \frac{\sqrt{3}}{2}$  and  $OP = 1$

As  $P$  lies in the second quadrant,  $x = -\frac{1}{2}$  and  $y = \frac{\sqrt{3}}{2}$

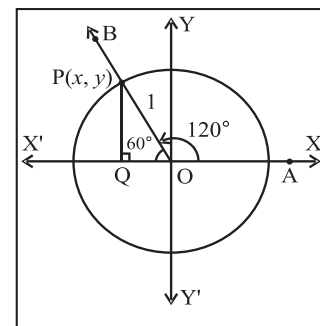

**Fig. 2.11**

$$\therefore \sin 120^\circ = y = \frac{\sqrt{3}}{2}$$

$$\cos 120^\circ = x = -\frac{1}{2}$$

$$\tan 120^\circ = \frac{y}{x} = \frac{\frac{\sqrt{3}}{2}}{-\frac{1}{2}} = -\sqrt{3}$$

$$\operatorname{cosec} 120^\circ = \frac{1}{y} = \frac{2}{\sqrt{3}}$$

$$\sec 120^\circ = \frac{1}{x} = -2$$

$$\cot 120^\circ = \frac{x}{y} = \frac{-\frac{1}{2}}{\frac{\sqrt{3}}{2}} = -\frac{1}{\sqrt{3}}$$

### 5) Angle of measure $225^\circ$ or $\left(\frac{5\pi}{4}\right)$

Let  $m \angle XOP = 225^\circ$ . Its terminal arm intersects unit circle in  $P(x, y)$ . Draw  $PQ$  perpendicular to the  $X$ -axis at  $Q$ .

$\therefore \triangle OPQ$   $45^\circ - 45^\circ - 90^\circ$  triangle.

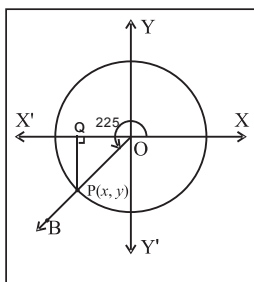

Fig. 2.12

$$\therefore OQ = \frac{1}{\sqrt{2}} \text{ and } PQ = \frac{1}{\sqrt{2}} \text{ and } OP = 1$$

As  $P$  lies in the third quadrant,  $x = -\frac{1}{\sqrt{2}}$  and  $y = -\frac{1}{\sqrt{2}}$

$$\therefore \sin 225^\circ = y = -\frac{1}{\sqrt{2}}$$

$$\cos 225^\circ = x = -\frac{1}{\sqrt{2}}$$

$$\tan 225^\circ = \frac{y}{x} = 1$$

$$\operatorname{cosec} 225^\circ = \frac{1}{y} = -\sqrt{2}$$

$$\sec 225^\circ = \frac{1}{x} = -\sqrt{2}$$

$$\cot 225^\circ = \frac{-\frac{1}{\sqrt{2}}}{-\frac{1}{\sqrt{2}}} = 1$$

### 2.1.3 Trigonometric functions of negative angles:

Let  $P(x, y)$  be any point on the unit circle with center at the origin such that  $\angle AOP = \theta$ .

If  $\angle AOQ = -\theta$ , then the co-ordinates of  $Q$  will be  $(x, -y)$ .

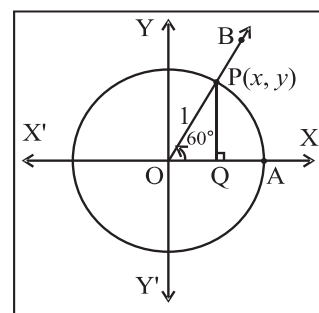

Fig. 2.13

By definition

$$\sin \theta = y \text{ and } \sin(-\theta) = -y$$

$$\cos \theta = x \text{ and } \cos(-\theta) = x$$

Therefore  $\sin(-\theta) = -\sin \theta$  and  $\cos(-\theta) = \cos \theta$

$$\tan(-\theta) = \frac{\sin(-\theta)}{\cos(-\theta)} = \frac{-\sin \theta}{\cos \theta} = -\tan \theta$$

$$\cot(-\theta) = \frac{\cos(-\theta)}{\sin(-\theta)} = \frac{\cos \theta}{-\sin \theta} = -\cot \theta$$

$$\sec(-\theta) = \frac{1}{\cos(-\theta)} = \frac{1}{\cos \theta} = \sec \theta$$

$$\operatorname{cosec}(-\theta) = \frac{1}{\sin(-\theta)} = \frac{1}{-\sin \theta} = -\operatorname{cosec} \theta$$

**6) Angle of measure  $-60^\circ$  or  $-\frac{\pi}{3}$  :**

Let  $m \angle XOP = -60^\circ$ .

Its terminal arm intersects unit circle in  $P(x, y)$ .

Draw  $PQ$  perpendicular to the  $X$ -axis.

$\therefore \Delta OPQ$  is  $30^\circ - 60^\circ - 90^\circ$  triangle.

$$OQ = \frac{1}{2} \text{ and } PQ = \frac{\sqrt{3}}{2} \text{ and } OP = 1$$

As  $P$  lies in the fourth quadrant,  $x = \frac{1}{2}$  and

$$y = -\frac{\sqrt{3}}{2}$$

$$\therefore \sin(-60^\circ) = y = -\frac{\sqrt{3}}{2}$$

$$\cos(-60^\circ) = x = \frac{1}{2}$$

$$\tan(-60^\circ) = \frac{y}{x} = \frac{-\frac{\sqrt{3}}{2}}{\frac{1}{2}} = -\sqrt{3}$$

$$\operatorname{cosec}(-60^\circ) = \frac{1}{y} = -\frac{2}{\sqrt{3}}$$

$$\sec(-60^\circ) = \frac{1}{x} = 2$$

$$\cot(-60^\circ) = \frac{x}{y} = \frac{\frac{1}{2}}{-\frac{\sqrt{3}}{2}} = -\frac{1}{\sqrt{3}}$$

**Note :** Angles  $-60^\circ$  and  $300^\circ$  are co-terminal angles therefore values of their trigonometric functions are same.

The trigonometric functions of  $0^\circ - 30^\circ - 45^\circ - 60^\circ - 90^\circ$  are tabulated in the following table.

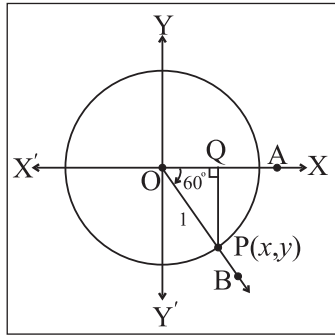

**Fig. 2.14**

Angles	Trig. Fun.	$\sin\theta$	$\cos\theta$
$360^\circ = 0^\circ$		0	1
$30^\circ = \frac{\pi^c}{6}$		$\frac{1}{2}$	$\frac{\sqrt{3}}{2}$
$45^\circ = \frac{\pi^c}{4}$		$\frac{1}{\sqrt{2}}$	$\frac{1}{\sqrt{2}}$
$60^\circ = \frac{\pi^c}{3}$		$\frac{\sqrt{3}}{2}$	$\frac{1}{2}$
$90^\circ = \frac{\pi^c}{2}$		1	0
$180^\circ = \pi$		0	-1
$270^\circ = 3\frac{3\pi}{2}$		-1	0

**(Activity) :**

Find trigonometric functions of angles  $150^\circ$ ,  $210^\circ$ ,  $330^\circ$ ,  $-45^\circ$ ,  $-120^\circ$ ,  $-\frac{3\pi}{4}$  and complete the table.

Trig. Fun.	$\sin \theta$	$\cos \theta$	$\tan \theta$	$\operatorname{cosec} \theta$	$\sec \theta$	$\cot \theta$
$\theta$ Angle						
$150^\circ$						
$210^\circ$						
$330^\circ$						
$-45^\circ$						
$-120^\circ$						
$-\frac{3\pi}{4}$						

**SOLVED EXAMPLES**

**Ex.1** For  $\theta = 30^\circ$ , Verify that  $\sin 2\theta = 2\sin\theta \cos\theta$

**Solution:** Given  $\theta = 30^\circ \therefore 2\theta = 60^\circ$

$$\sin\theta = \sin 30^\circ = \frac{1}{2}$$

$$\cos\theta = \cos 30^\circ = \frac{\sqrt{3}}{2}$$

$$\sin 2\theta = \sin 60^\circ = \frac{\sqrt{3}}{2}$$

$$\begin{aligned} \text{L.H.S.} &= 2\sin\theta \cos\theta = 2 \times \frac{1}{2} \times \frac{\sqrt{3}}{2} \\ &= \frac{\sqrt{3}}{2} = \sin 2\theta = \text{R.H.S.} \end{aligned}$$

**Ex.2** Evaluate the following :

i)  $\cos 30^\circ \times \cos 60^\circ + \sin 30^\circ \times \sin 60^\circ$

ii)  $4\cos^3 45^\circ - 3\cos 45^\circ + \sin 45^\circ$

iii)  $\sin^2 0 + \sin^2 \frac{\pi}{6} + \sin^2 \frac{\pi}{3} + \sin^2 \frac{\pi}{2}$

iv)  $\sin \pi + 2 \cos \pi + 3 \sin \frac{3\pi}{2} + 4 \cos \frac{3\pi}{2}$   
 $- 5 \sec \pi - 6 \operatorname{cosec} \frac{3\pi}{2}$

**Solution :**

i)  $\cos 30^\circ \times \cos 60^\circ + \sin 30^\circ \times \sin 60^\circ$

$$= \frac{\sqrt{3}}{2} \times \frac{1}{2} + \frac{1}{2} \times \frac{\sqrt{3}}{2} = \frac{\sqrt{3}}{2}$$

ii)  $4\cos^3 45^\circ - 3\cos 45^\circ + \sin 45^\circ$

$$= 4 \left( \frac{1}{\sqrt{2}} \right)^3 - 3 \frac{1}{\sqrt{2}} + \frac{1}{\sqrt{2}}$$

$$= 4 \frac{1}{2\sqrt{2}} - \frac{2}{\sqrt{2}}$$

$$= \frac{2}{\sqrt{2}} - \frac{2}{\sqrt{2}} = 0$$

iii)  $\sin^2 0 + \sin^2 \frac{\pi}{6} + \sin^2 \frac{\pi}{3} + \sin^2 \frac{\pi}{2}$

$$= (0)^2 + \left( \frac{1}{2} \right)^2 + \left( \frac{\sqrt{3}}{2} \right)^2 + (1)^2$$

$$= 0 + \frac{1}{4} + \frac{3}{4} + 1 = 2$$

iv)  $\sin \pi + 2 \cos \pi + 3 \sin \frac{3\pi}{2} + 4 \cos \frac{3\pi}{2}$

$$- 5 \sec \pi - 6 \operatorname{cosec} \frac{3\pi}{2}$$

$$= 0 + 2(-1) + 3(-1) + 4(0) - 5(-1) - 6(-1)$$

$$= 0 - 2 - 3 + 0 + 5 + 6 = 6$$

**Ex.3** Find all trigonometric functions of the angle made by OP with X-axis where P is (-5, 12).

**Solution:** Let  $\theta$  be the measure of the angle in standard position whose terminal arm passes through P(-5, 12).

$$r = OP = \sqrt{(-5)^2 + 12^2} = 13$$

$$P(x, y) = (-5, 12) \therefore x = -5, y = 12$$

$$\sin\theta = \frac{y}{r} = \frac{12}{13} \quad \operatorname{cosec}\theta = \frac{r}{y} = \frac{13}{12}$$

$$\cos\theta = \frac{x}{r} = \frac{-5}{13} \quad \sec\theta = \frac{r}{x} = \frac{-13}{12}$$

$$\tan\theta = \frac{y}{x} = \frac{-12}{5} \quad \cot\theta = \frac{x}{y} = \frac{-5}{12}$$

**Ex.4**  $\sec\theta = -3$  and  $\pi < \theta < \frac{3\pi}{2}$  then find the values of other trigonometric functions.

**Solution :** Given  $\sec \theta = -3$

$$\therefore \cos\theta = -\frac{1}{3}$$

$$\text{We have } \tan^2 \theta = \sec^2 \theta - 1$$

$$\therefore \tan^2 \theta = 9 - 1 = 8$$

$\therefore \tan^2 \theta = 8$  and  $\pi < \theta < \frac{3\pi}{2}$ , the third quadrant.

$$\therefore \tan \theta = 2\sqrt{2} \text{ Hence } \cot\theta = \frac{1}{2\sqrt{2}}$$

$$\text{Also we have, } \sin \theta = \tan \theta \cos \theta$$

$$= 2\sqrt{2} \left( -\frac{1}{3} \right) = -\frac{2\sqrt{2}}{3}$$

$$\therefore \operatorname{cosec}\theta = -\frac{3}{2\sqrt{2}}$$

**Ex.5** If  $\sec x = \frac{13}{5}$ ,  $x$  lies in the fourth quadrant, find the values of other trigonometric functions.

**Solution :** Since  $\sec x = \frac{13}{5}$ , we have  $\cos x = \frac{5}{13}$

$$\text{Now } \tan^2 x = \sec^2 x - 1$$

$$\therefore \tan^2 x = \left(\frac{13}{5}\right)^2 - 1 = \frac{169}{25} - 1 = \frac{144}{25}$$

$\therefore \tan x = \frac{144}{25}$  and  $x$  lies in the fourth quadrant.

$$\therefore \tan x = \frac{-12}{5} \quad \cot x = -\frac{5}{12}$$

Further we have,  $\sin x = \tan x \times \cos x$

$$= -\frac{12}{5} \times \frac{5}{13} = -\frac{12}{13}$$

$$\text{And } \operatorname{cosec} x = \frac{1}{\sin x} = -\frac{13}{12}$$

**Ex.6** If  $\tan A = \frac{4}{3}$ , find the value of

$$\frac{2 \sin A - 3 \cos A}{2 \sin A + 3 \cos A}$$

**Solution :** Given expression

$$\frac{2 \sin A - 3 \cos A}{2 \sin A + 3 \cos A} = \frac{2 \frac{\sin A}{\cos A} - 3 \frac{\cos A}{\cos A}}{2 \frac{\sin A}{\cos A} + 3 \frac{\cos A}{\cos A}}$$

$$= \frac{2 \tan A - 3}{2 \tan A + 3}$$

$$= \frac{2\left(\frac{4}{3}\right) - 3}{2\left(\frac{4}{3}\right) + 3} = -\frac{1}{17}$$

**Ex.7** If  $\sec \theta = \sqrt{2}$ ,  $\frac{3\pi}{2} < \theta < 2\pi$  then find the

value of  $\frac{1 + \tan \theta + \operatorname{cosec} \theta}{1 + \cot \theta - \operatorname{cosec} \theta}$ .

**Solution :** Given  $\sec \theta = \sqrt{2}$   $\therefore \cos \theta = \frac{1}{\sqrt{2}}$

$$\text{Now } \tan^2 \theta = \sec^2 \theta - 1 = 2 - 1 = 1$$

$\therefore \tan^2 \theta = 1$  and  $\frac{3\pi}{2} < \theta < 2\pi$  (the fourth quadrant)

$$\therefore \tan \theta = -1. \text{ Hence } \cot \theta = -1$$

$$\text{Now } \sin \theta = \tan \theta \cos \theta = (-1) \left(\frac{1}{\sqrt{2}}\right) = -\frac{1}{\sqrt{2}}$$

$$\text{Hence } \operatorname{cosec} \theta = -\sqrt{2}$$

$$\frac{1 + \tan \theta + \operatorname{cosec} \theta}{1 + \cot \theta - \operatorname{cosec} \theta} = \frac{1 + (-1) + (-\sqrt{2})}{1 + (-1) - (-\sqrt{2})} = -1$$

**Ex.8** If  $\sin \theta = -\frac{3}{5}$  and  $180^\circ < \theta < 270^\circ$  then find all trigonometric functions of  $\theta$ .

**Solution :** Since  $180^\circ < \theta < 270^\circ$ ,  $\theta$  lies in the third quadrant.

$$\text{Since, } \sin \theta = -\frac{3}{5} \quad \therefore \operatorname{cosec} \theta = -\frac{5}{3}$$

$$\text{Now } \cos^2 \theta = 1 - \sin^2 \theta$$

$$\therefore \cos^2 \theta = 1 - \frac{9}{25} = \frac{16}{25}$$

$$\therefore \cos \theta = -\frac{4}{5} \quad \therefore \sec \theta = -\frac{5}{4}$$

$$\text{Now } \tan \theta = \frac{\sin \theta}{\cos \theta}$$

$$\therefore \tan \theta = \frac{3}{4} \quad \therefore \cot \theta = \frac{4}{3}$$

### EXERCISE 2.1

- Find the trigonometric functions of  $0^\circ, 30^\circ, 45^\circ, 60^\circ, 150^\circ, 180^\circ, 210^\circ, 300^\circ, 330^\circ, -30^\circ, -45^\circ, -60^\circ, -90^\circ, -120^\circ, -225^\circ, -240^\circ, -270^\circ, -315^\circ$
- State the signs of
  - $\tan 380^\circ$
  - $\cot 230^\circ$
  - $\sec 468^\circ$
- State the signs of  $\cos 4^\circ$  and  $\cos 4^\circ$ . Which of these two functions is greater?

- 4) State the quadrant in which  $\theta$  lies if
- $\sin\theta < 0$  and  $\tan\theta > 0$
  - $\cos\theta < 0$  and  $\tan\theta > 0$
- 5) Evaluate each of the following :
- $\sin 30^\circ + \cos 45^\circ + \tan 180^\circ$
  - $\operatorname{cosec} 45^\circ + \cot 45^\circ + \tan 0^\circ$
  - $\sin 30^\circ \times \cos 45^\circ \times \tan 360^\circ$
- 6) Find all trigonometric functions of angle in standard position whose terminal arm passes through point (3, -4).
- 7) If  $\cos\theta = \frac{12}{13}$ ,  $0 < \theta < \frac{\pi}{2}$ , find the value of  $\frac{\sin^2 \theta - \cos^2 \theta}{2 \sin \theta \cos \theta}, \frac{1}{\tan^2 \theta}$
- 8) Using tables evaluate the following :
- $4\cot 45^\circ - \sec^2 60^\circ + \sin 30^\circ$
  - $\cos^2 0 + \cos^2 \frac{\pi}{6} + \cos^2 \frac{\pi}{3} + \cos^2 \frac{\pi}{2}$
- 9) Find the other trigonometric functions if
- If  $\cos\theta = -\frac{3}{5}$  and  $180^\circ < \theta < 270^\circ$ .
  - If  $\sec A = -\frac{25}{7}$  and A lies in the second quadrant.
  - If  $\cot x = \frac{3}{4}$ , x lies in the third quadrant.
  - $\tan x = \frac{-5}{12}$ , x lies in the fourth quadrant.



### Let's Learn

## Fundamental Identities

### 2.2 Fundamental Identities :

A trigonometric identity represents a relationship that is always for all admissible

values in the domain. For example  $\operatorname{cosec}\theta = \frac{1}{\sin\theta}$  is true for all admissible values of  $\theta$ . Hence this is an identity. Identities enable us to simplify complicated expressions. They are basic tools of trigonometry which are being used in solving trigonometric equations.

The fundamental identities of trigonometry, namely.

$$1) \quad \sin^2 \theta + \cos^2 \theta = 1,$$

using this identity we can derive simple relations in trigonometry functions

$$\text{e.g. } \cos\theta = \pm\sqrt{1 - \sin^2 \theta} \quad \text{and}$$

$$\sin\theta = \pm\sqrt{1 - \cos^2 \theta}$$

$$2) \quad 1 + \tan^2 \theta = \sec^2 \theta, \quad \text{if } \theta \neq \frac{\pi}{2}$$

$$3) \quad 1 + \cot^2 \theta = \operatorname{cosec}^2 \theta, \quad \text{if } \theta \neq 0$$

These relations are called fundamental identities of trigonometry.

### 2.2.1 Domain and Range of Trigonometric

**functions :** Now we will find domain and range of trigonometric functions expressed as follows.

We now study  $\sin \theta$ ,  $\cos \theta$ ,  $\tan \theta$  as functions of real variable  $\theta$ . Here  $\theta$  is measured in radians.

We have defined  $\sin\theta$  and  $\cos \theta$ , where  $\theta$  is a real number. If  $\alpha$  and  $\theta$  are co-terminal angles and if  $0^\circ \leq \alpha \leq 360^\circ$ , then  $\sin \theta = \sin\alpha$ , and  $\cos \theta = \cos\alpha$ . Hence the domain of these function is R.

Let us find the range  $\sin \theta$  and  $\cos \theta$

$$\text{We have, } \sin^2\theta + \cos^2\theta = 1$$

- i) Consider  $y = \sin\theta$  where  $\theta \in R$  and  $y \in [-1, 1]$

The domain of sine function is  $\mathbb{R}$  and range is  $[-1, 1]$ .

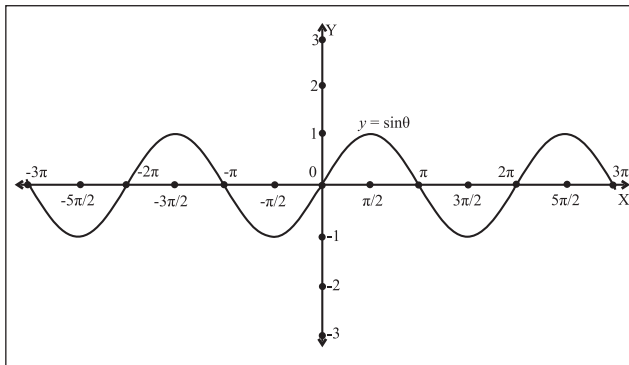

Fig. 2.15

- ii) Consider  $y = \cos\theta$  where  $\theta \in \mathbb{R}$  and  $y \in [-1, 1]$   
The domain of cosine function is  $\mathbb{R}$  and range is  $[-1, 1]$ .

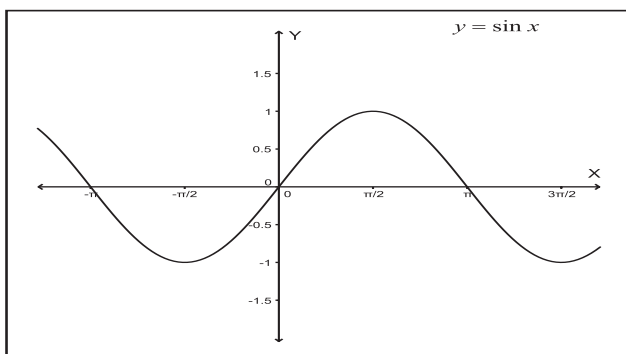

Fig. 2.16

- iii) Consider  $y = \tan\theta$ ,  $\tan\theta$  does not exist for  $\theta = \pm \frac{\pi}{2}, \pm \frac{3\pi}{2}, \pm \frac{5\pi}{2}, \dots$   
In general  $\tan\theta$  does not exist if  $\theta = (2n + 1) \frac{\pi}{2}$ , where  $n \in \mathbb{I}$

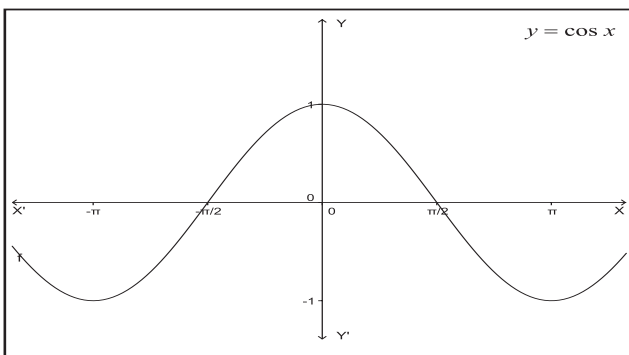

Fig. 2.17

The domain of  $\tan\theta$  is  $\mathbb{R}$  except

$$\theta = (2n + 1) \frac{\pi}{2},$$

As  $\theta \rightarrow \frac{\pi}{2}^-$ ,  $\tan\theta \rightarrow +\infty$  and as  $\theta \rightarrow \frac{\pi}{2}^+$ ,  $\tan\theta \rightarrow -\infty$ .

when you learn the concept of the limits you will notice.

Since  $\tan\theta = \frac{y}{x}$ , value of  $\tan\theta$  can be any real number, range of  $\tan$  function is  $\mathbb{R}$ .

- iv) Consider  $y = \operatorname{cosec}\theta$   
 $\operatorname{cosec}\theta$  does not exist for  $\theta = 0, \pm\pi, \pm 2\pi, \pm 3\pi, \dots$

In general  $\operatorname{cosec}\theta$  does not exist if  $\theta = n\pi$ , where  $n \in \mathbb{I}$ .

The domain of  $\operatorname{cosec}\theta$  is  $\mathbb{R}$  except  $\theta = n\pi$ , and range is  $\mathbb{R}$ .

The domain of sine function is  $\mathbb{R}$  and range is  $[-1, 1]$ .

Now as  $-1 \leq \sin\theta \leq 1$ ,  $\operatorname{cosec}\theta \geq 1$

$$\text{or } \operatorname{cosec}\theta \leq -1.$$

$\therefore$  The range of cosecant function is

$$\{y \in \mathbb{R} : |y| \geq 1\} = \mathbb{R} - (-1, 1)$$

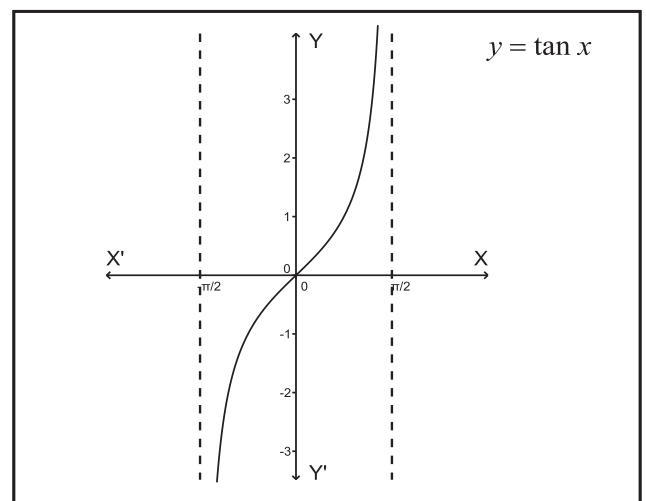

Fig. 2.18

v) Consider  $y = \sec\theta$   
 $\sec\theta$  does not exist for  $\theta = \pm\frac{\pi}{2}, \pm\frac{3\pi}{2}, \pm\frac{5\pi}{2} \dots$

In general  $\sec\theta$  does not exist if

$$\theta = (2n + 1) \frac{\pi}{2}, \text{ where } n \in I.$$

The domain of  $\sec\theta$  is  $\mathbb{R}$  except  $\theta = (2n + 1) \frac{\pi}{2}$ , and range is  $\mathbb{R} - (-1, 1)$

Now as  $-1 \leq \cos\theta \leq 1$ ,  $\sec\theta \geq 1$  or  $\sec\theta \leq -1$   
 $\therefore$  The range of secant function is  $\{y \in \mathbb{R} : |y| \geq 1\} = \mathbb{R} - (-1, 1)$

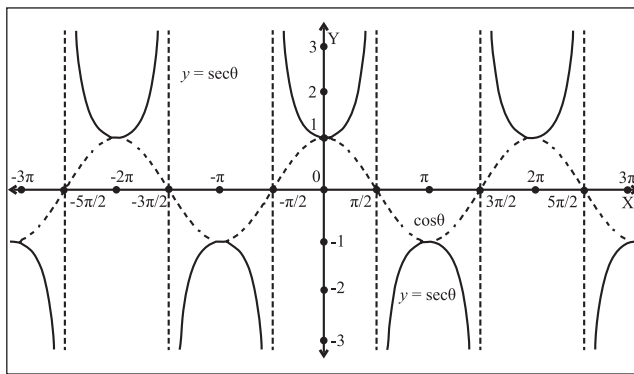

Fig. 2.19

vi) Consider  $y = \cot\theta$   
 $\cot\theta$  does not exist for  $\theta = 0, \pm\pi, \pm2\pi, \pm3\pi \dots$

In general  $\cot\theta$  does not exist if  $\theta = n\pi$ , where  $n \in I$ .

The domain of  $\cot\theta$  is  $\mathbb{R}$  except  $\theta = n\pi$ , and range is  $\mathbb{R}$ .

The domain of sine function is  $\mathbb{R}$  and range is  $[-1, 1]$ .

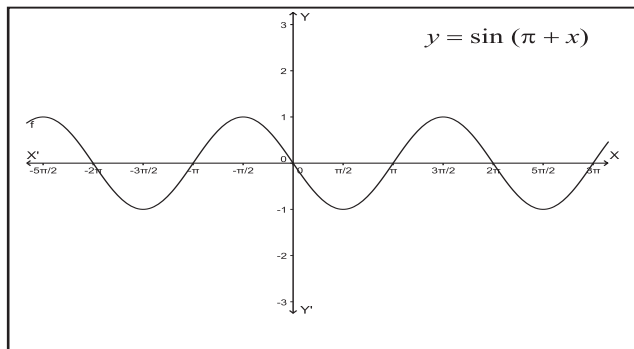

Fig. 2.20

Now as  $-1 \leq \cos\theta \leq 1$ ,  $\sec\theta \geq 1$  or  $\sec\theta \leq -1$   
 Similarly,  $-1 \leq \sin\theta \leq 1$ ,  $\operatorname{cosec}\theta \geq 1$  or  $\operatorname{cosec}\theta \leq -1$

Since  $\cot\theta = \frac{y}{x}$ , value of  $\cot\theta$  can be any real number, range of  $\cot$  function is  $\mathbb{R}$ .

### 2.2.2 Periodicity of Trigonometric functions:

A function is said to be a periodic function if there exists a constant  $p$  such that  $f(x + p) = f(x)$  for all  $x$  in the domain.

$$\therefore f(x) = f(x + p) = f(x + 2p) = \dots = f(x - p) = f(x - 2p) = \dots$$

The smallest positive value of  $p$  which satisfies the above relation is called the fundamental period or simply the period of  $f$ .

$$\text{Ex. } \sin(x + 2\pi) = \sin(x + 4\pi) = \sin x = \sin(x - 2\pi) = \sin(x - 4\pi)$$

Thus  $\sin x$  is a periodic function with period  $2\pi$ .

Similarly  $\cos x$ ,  $\operatorname{cosec} x$  and  $\sec x$  are periodic functions with period  $2\pi$ .

But  $\tan x$  and  $\cot x$  are periodic functions with period  $\pi$ . Because of  $\tan(x + \pi) = \tan x$  for all  $x$ .

The following table gives the domain, range and period of trigonometric functions.

Trigonometric functions	Domain	Range	Period
$\sin\theta$	$\mathbb{R}$	$[-1, 1]$	$2\pi$
$\cos\theta$	$\mathbb{R}$	$[-1, 1]$	$2\pi$
$\tan\theta$	$\mathbb{R} - \{(2n + 1) \frac{\pi}{2} : n \in I\}$	$\mathbb{R}$	$\pi$
$\operatorname{cosec}\theta$	$\mathbb{R} - \{n\pi : n \in I\}$	$\mathbb{R} - (-1, 1)$	$2\pi$
$\sec\theta$	$\mathbb{R} - \{(2n + 1) \frac{\pi}{2} : n \in I\}$	$\mathbb{R} - (-1, 1)$	$2\pi$
$\cot\theta$	$\mathbb{R} - \{n\pi : n \in I\}$	$\mathbb{R}$	$\pi$

**SOLVED EXAMPLES**

**Ex.1** Find the value of  $\sin \frac{41\pi}{4}$ .

**Solution :** We know that sine function is periodic with period  $2\pi$ .

$$\therefore \sin \frac{41\pi}{4} = \sin \left( 10\pi + \frac{\pi}{4} \right) = \sin \frac{\pi}{4} = \frac{1}{\sqrt{2}}$$

**Ex.2** Find the value of  $\cos 765^\circ$ .

**Solution :** We know that cosine function is periodic with period  $2\pi$ .

$$\begin{aligned} \therefore \cos 765^\circ &= \cos(720^\circ + 45^\circ) \\ &= \cos(2 \times 360^\circ + 45^\circ) \\ &= \cos 45^\circ = \frac{1}{\sqrt{2}} \end{aligned}$$



**Let's Learn**

**2.9 Graphs of trigonometric functions :**

**Introduction :** In this section we shall study the graphs of trigonometric functions. Consider  $x$  to be a real number or measure of an angle in radian. We know that all trigonometric functions are periodic. The periods of sine and cosine functions is  $2\pi$  and the period of tangent function is  $\pi$ . These periods are measured in radian.

**(i) The graph of sine function:**

Consider  $y = \sin x$ , for  $-\pi < x < \pi$ . Here  $x$  represents a variable angle. The table of values is as follows:

$x$	0	$\frac{\pi}{6}$	$\frac{\pi}{4}$	$\frac{\pi}{3}$	$\frac{\pi}{2}$	$\frac{2\pi}{3}$	$\frac{3\pi}{4}$	$\frac{5\pi}{6}$	$\pi$
$y$	0	0.5	0.71	0.87	1	0.87	0.71	0.5	0

Using the result  $\sin(-\theta) = -\sin\theta$ , we have following table:

$x$	$-\pi$	$-\frac{5\pi}{6}$	$-\frac{3\pi}{4}$	$-\frac{2\pi}{3}$	$-\frac{\pi}{2}$	$-\frac{\pi}{3}$	$-\frac{\pi}{4}$	$-\frac{\pi}{6}$	0
$y$	0	-0.5	-0.71	-0.87	-1	-0.87	-0.71	-0.5	0

Take the horizontal axis to be the  $X$ - axis and the vertical axis to be the  $Y$ - axis.

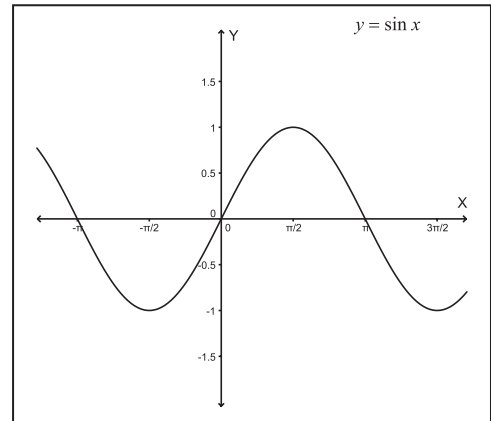

**Fig. 2.21**

The graph of  $y = \sin x$  is shown above. Since the period of sine function is  $2\pi$  It means that take the curve and shift it  $2\pi$  to left or right, then the curve falls back on itself. Also note that the graph is within one unit of the  $Y$ - axis. The graph increases and decreases periodically.

**(ii) The graph of cosine function:** Consider  $y = \cos x$ , for  $-\pi < x < \pi$ . Here  $x$  represents a variable angle. The table of values is as follows:

$x$	0	$\frac{\pi}{6}$	$\frac{\pi}{4}$	$\frac{\pi}{3}$	$\frac{\pi}{2}$	$\frac{2\pi}{3}$	$\frac{3\pi}{4}$	$\frac{5\pi}{6}$	$\pi$
$y$	1	0.87	0.71	0.5	0	0.5	0.71	0.87	1

Using the result  $\cos(-\theta) = \cos\theta$ , we have following table:

$x$	$-\pi$	$-\frac{5\pi}{6}$	$-\frac{3\pi}{4}$	$-\frac{2\pi}{3}$	$-\frac{\pi}{2}$	$-\frac{\pi}{3}$	$-\frac{\pi}{4}$	$-\frac{\pi}{6}$	0
$Y$	1	0.87	0.71	0.5	0	0.5	0.71	0.87	1

Take the horizontal axis to be the  $X$ - axis and the vertical axis to be the  $Y$ - axis.

The graph of  $y = \cos x$  is shown below. Since the period of cosine function is  $2\pi$ . It means that take the curve and shift it  $2\pi$  to left or right, then the curve falls back on itself. Also note that the graph is with in one unit of the  $Y$ - axis. The graph increases and decreases periodically.

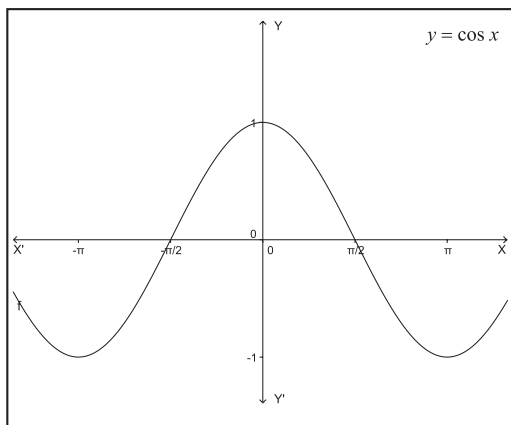

Fig. 2.22

**(iii) The graph of tangent function:**

Let  $y = \tan x$  for  $-\frac{\pi}{2} < x < \frac{\pi}{2}$

Note that does not exist for  $x = \frac{\pi}{2}$ . As  $x$  increases from 0 to  $\frac{\pi}{2}$  :

- 1)  $\sin x$  increases from 0 to 1 and
- 2)  $\cos x$  decreases from 1 to 0.

$\therefore \tan x = \frac{\sin x}{\cos x}$  will increase indefinitely as  $x$  starting from 0 approaches to  $\frac{\pi}{2}$ . Similarly starting from 0 approaches to  $-\frac{\pi}{2}$ ,  $\tan x$  decreases indefinitely. The corresponding values of  $x$  and  $y$  are as in the following table:

$x$	$-\frac{\pi}{3}$	$-\frac{\pi}{4}$	$-\frac{\pi}{6}$	0	$\frac{\pi}{6}$	$\frac{\pi}{4}$	$\frac{\pi}{3}$
$y$	-1.73	-1	-0.58	0	0.58	1	1.73

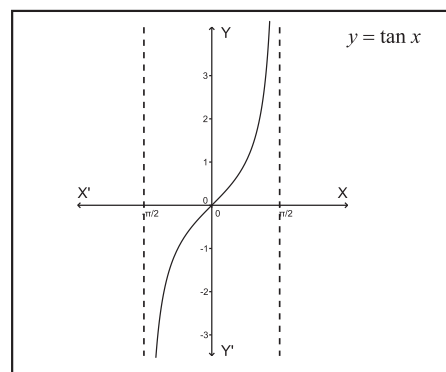

Fig. 2.23

**(Activity) :**

- 1) Use the tools in Geogebra to draw the different types of graphs of trigonometric functions.

Geogebra is an open source application available on internet.

- 2) Plot the graphs of cosecant, secant and cotangent functions.

**SOLVED EXAMPLES**

**Ex. 1** If  $\tan \theta + \frac{1}{\tan \theta} = 2$  then find the value of  $\tan^2 \theta + \frac{1}{\tan^2 \theta}$

**Solution :** We have  $\tan \theta + \frac{1}{\tan \theta} = 2$

Squaring both sides, we get

$$\tan^2 \theta + 2 \tan \theta \times \frac{1}{\tan \theta} + \frac{1}{\tan^2 \theta} = 4$$

$$\therefore \tan^2 \theta + 2 + \frac{1}{\tan^2 \theta} = 4$$

$$\therefore \tan^2 \theta + \frac{1}{\tan^2 \theta} = 2$$

**Ex. 2** Which of the following is true?

i)  $2 \cos^2 \theta = \frac{1 - \tan^2 \theta}{1 + \tan^2 \theta}$

ii)  $\frac{\cot A - \tan B}{\cot B - \tan A} = \cot A \tan B$

$$\text{iii) } \frac{\cos \theta}{1-\tan \theta} + \frac{\sin \theta}{1-\cot \theta} = \sin \theta + \cos \theta \qquad = \frac{(\cos \theta - \sin \theta)(\cos \theta + \sin \theta)}{\cos \theta - \sin \theta}$$

$$= \sin \theta + \cos \theta = \text{RHS}$$

**Solution :**

$$\text{i) } 2 \cos^2 \theta = \frac{1-\tan^2 \theta}{1+\tan^2 \theta}$$

$$\text{RHS} = \frac{1-\tan^2 \theta}{1+\tan^2 \theta}$$

$$= \frac{1-\frac{\sin^2 \theta}{\cos^2 \theta}}{1+\frac{\sin^2 \theta}{\cos^2 \theta}}$$

$$= \frac{\cos^2 \theta - \sin^2 \theta}{\cos^2 \theta + \sin^2 \theta}$$

$$= \cos^2 \theta - \sin^2 \theta$$

$$= \cos^2 \theta - (1 - \cos^2 \theta)$$

$$= 2\cos^2 \theta - 1 \neq \text{LHS}$$

Since the LHS  $\neq$  RHS, given equation is not true.

$$\text{ii) } \frac{\cot A - \tan B}{\cot B - \tan A} = \cot A \tan B$$

**Solution :** Substitute  $A = B = 45^\circ$

$$\text{LHS} = \frac{\cot 45^\circ - \tan 45^\circ}{\cot 45^\circ - \tan 45^\circ}$$

$$= \frac{1 - 1}{1 - 1} = \frac{0}{0} = 0$$

$$\text{RHS} = \cot 45^\circ \tan 45^\circ = 1$$

As LHS  $\neq$  RHS, the given equation is not true.

**Note :** 'One counter example is enough' to prove that a mathematical statement is wrong.

$$\text{iii) } \frac{\cos \theta}{1-\tan \theta} + \frac{\sin \theta}{1-\cot \theta} = \sin \theta + \cos \theta$$

$$\text{LHS} = \frac{\cos \theta}{1-\tan \theta} + \frac{\sin \theta}{1-\cot \theta}$$

$$= \frac{\cos^2 \theta}{\cos \theta - \sin \theta} + \frac{\sin^2 \theta}{\sin \theta - \cos \theta}$$

$$= \frac{\cos^2 \theta - \sin^2 \theta}{\cos \theta - \sin \theta}$$

Since the LHS = RHS, given equation is true.

**Ex.3** If  $5 \tan A = \sqrt{2}$ ,  $\pi < A < \frac{3\pi}{2}$  and

$\sec B = \sqrt{11}$ ,  $\frac{3\pi}{2} < B < 2\pi$  then find the value of  $\operatorname{cosec} A - \tan B$ .

**Solution :**  $5 \tan A = \sqrt{2}$

$$\therefore \tan A = \frac{\sqrt{2}}{5} \text{ and } \cot A = \frac{5}{\sqrt{2}}$$

As  $\operatorname{cosec}^2 A = 1 + \cot^2 A$

$$= 1 + \left(\frac{5}{\sqrt{2}}\right)^2 = \frac{27}{2}$$

$\therefore \operatorname{cosec}^2 A = \frac{27}{2}$  and  $\pi < A < \frac{3\pi}{2}$  (the third quadrant)

$$\therefore \operatorname{cosec} A = -\frac{\sqrt{27}}{\sqrt{2}}$$

Now  $\sec B = \sqrt{11}$

As  $\tan^2 B = \sec^2 B - 1 = 10$

Thus,  $\tan^2 B = 10$  and  $\frac{3\pi}{2} < B < \pi$  (the fourth quadrant)

$$\therefore \tan B = -\sqrt{10}$$

$$\text{Now } \operatorname{cosec} A - \tan B = -\frac{\sqrt{27}}{\sqrt{2}} - (-\sqrt{10})$$

$$= \frac{\sqrt{20} - \sqrt{27}}{\sqrt{2}}$$

**Ex.4** If  $\tan \theta = \frac{1}{\sqrt{7}}$  then evaluate

$$\frac{\operatorname{cosec}^2 \theta - \sec^2 \theta}{\operatorname{cosec}^2 \theta + \sec^2 \theta}$$

**Solution :** Given  $\tan \theta = \frac{1}{\sqrt{7}}$

$$\therefore \cot \theta = \sqrt{7}$$

Since,  $\operatorname{cosec}^2\theta = 1 + \cot^2\theta$

$$\sec^2\theta = 1 + \tan^2\theta$$

$$\therefore \operatorname{cosec}^2\theta - \sec^2\theta = \cot^2\theta - \tan^2\theta$$

$$\therefore \operatorname{cosec}^2\theta + \sec^2\theta = \cot^2\theta + \tan^2\theta + 2$$

$$\begin{aligned} \frac{\operatorname{cosec}^2\theta - \sec^2\theta}{\operatorname{cosec}^2\theta + \sec^2\theta} &= \frac{\cot^2\theta - \tan^2\theta}{\cot^2\theta + \tan^2\theta + 2} \\ &= \frac{7 - \frac{1}{7}}{7 + \frac{1}{7} + 2} = \frac{48}{64} = \frac{3}{4} \end{aligned}$$

**Ex.5** Prove that  $\cos^6\theta + \sin^6\theta = 1 - 3\sin^2\theta \cos^2\theta$

**Solution :**  $(a^3+b^3) = (a+b)^3 - 3ab(a+b)$

$$\text{L.H.S.} = \cos^6\theta + \sin^6\theta$$

$$= (\cos^2\theta)^3 + (\sin^2\theta)^3$$

$$= (\cos^2\theta + \sin^2\theta)^3 - 3\cos^2\theta \sin^2\theta (\cos^2\theta + \sin^2\theta)$$

$$= 1 - 3\sin^2\theta \cos^2\theta \quad (\text{Since } \sin^2\theta + \cos^2\theta = 1)$$

$$= \text{R.H.S.}$$

**Ex.6** Eliminate  $\theta$  from the following :

(i)  $x = a \cos\theta, \quad y = b \sin\theta$

(ii)  $x = a \cos^3\theta, \quad y = b \sin^3\theta$

(iii)  $x = 2+3\cos\theta, \quad y = 5+3\sin\theta$

**Solution :**

(i)  $x = a \cos\theta, \quad y = b \sin\theta$

$$\therefore \cos\theta = \frac{x}{a} \text{ and } \sin\theta = \frac{y}{b}$$

On squaring and adding, we get

$$\cos^2\theta + \sin^2\theta = \frac{x^2}{a^2} + \frac{y^2}{b^2}$$

$$\text{but } \sin^2\theta + \cos^2\theta = 1$$

$$\therefore \frac{x^2}{a^2} + \frac{y^2}{b^2} = 1$$

(ii)  $x = a \cos^3\theta, \quad y = b \sin^3\theta$

$$\therefore \cos^3\theta = \frac{x}{a} \text{ and } \sin^3\theta = \frac{y}{b}$$

$$\therefore \cos\theta = \left(\frac{x}{a}\right)^{\frac{1}{3}} \text{ and } \sin\theta = \left(\frac{y}{b}\right)^{\frac{1}{3}}$$

On squaring and adding, we get

$$\cos^2\theta + \sin^2\theta = \left(\frac{x}{a}\right)^{\frac{2}{3}} + \left(\frac{y}{b}\right)^{\frac{2}{3}}$$

$$\text{but } \sin^2\theta + \cos^2\theta = 1$$

$$\therefore \left(\frac{x}{a}\right)^{\frac{2}{3}} + \left(\frac{y}{b}\right)^{\frac{2}{3}} = 1$$

(iii)  $x = 2+3 \cos\theta, \quad y = 5+3 \sin\theta$

$$x - 2 = 3 \cos\theta, \quad y - 5 = 3 \sin\theta$$

$$\cos\theta = \left(\frac{x-2}{3}\right), \quad \sin\theta = \left(\frac{y-5}{3}\right)$$

We know that,

$$\cos^2\theta + \sin^2\theta = 1$$

Therefore,

$$\left(\frac{x-2}{3}\right)^2 + \left(\frac{y-5}{3}\right)^2 = 1$$

$$\therefore (x-2)^2 + (y-5)^2 = (3)^2$$

$$\therefore (x-2)^2 + (y-5)^2 = 9$$

**Ex.7** If  $2\sin^2\theta + 7\cos\theta = 5$  then find the permissible values of  $\cos\theta$ .

**Solution :** We know that  $\sin^2\theta = 1 - \cos^2\theta$

Given equation  $2\sin^2\theta + 7\cos\theta = 5$  becomes

$$2(1 - \cos^2\theta) + 7\cos\theta = 5$$

$$\therefore 2 - 2\cos^2\theta + 7\cos\theta - 5 = 0$$

$$\therefore 2\cos^2\theta - 7\cos\theta + 3 = 0$$

$$\therefore 2\cos^2\theta - 6\cos\theta - \cos\theta + 3 = 0$$

$$\therefore (2\cos\theta - 1)(\cos\theta - 3) = 0$$

$$\therefore \cos\theta = 3 \text{ or } \cos\theta = \frac{1}{2}$$

But  $\cos\theta$  cannot be greater than 1

$$\therefore \text{Permissible value of } \cos\theta \text{ is } \frac{1}{2}.$$

**Ex. 8** Solve for  $\theta$ , if  $4 \sin^2 \theta - 2(\sqrt{3} + 1) \sin \theta + \sqrt{3} = 0$

**Solution :**  $4 \sin^2 \theta - 2(\sqrt{3} + 1) \sin \theta + \sqrt{3} = 0$  is a quadratic equation in  $\sin \theta$ . Its roots are given by

$$\frac{-b \pm \sqrt{b^2 - 4ac}}{2a}$$

where  $a = 4, b = -2(\sqrt{3} + 1), c = \sqrt{3}$

$$\therefore \sin \theta = \frac{2(\sqrt{3} + 1) \pm 2\sqrt{[2(\sqrt{3} + 1)]^2 - 4(4)(\sqrt{3})}}{2(4)}$$

$$= \frac{2(\sqrt{3} + 1) \pm 2\sqrt{[(\sqrt{3} + 1)]^2 - (4)(\sqrt{3})}}{2(4)}$$

$$= \frac{(\sqrt{3} + 1) \pm \sqrt{[(\sqrt{3} + 1)]^2 - (4)(\sqrt{3})}}{(4)}$$

$$= \frac{(\sqrt{3} + 1) \pm \sqrt{3 + 2\sqrt{3} + 1 - 4(\sqrt{3})}}{4}$$

$$= \frac{(\sqrt{3} + 1) \pm \sqrt{4 - 2(\sqrt{3})}}{4}$$

$$= \frac{(\sqrt{3} + 1) \pm \sqrt{[\sqrt{3} - 1]^2}}{4}$$

$$= \frac{(\sqrt{3} + 1) \pm (\sqrt{3} - 1)}{4}$$

$$= \frac{\sqrt{3}}{2} \text{ or } \frac{1}{2}$$

$$\therefore \theta = \frac{\pi}{6} \text{ or } \frac{\pi}{3}$$

**Ex. 9** If  $\tan \theta + \sec \theta = 1.5$  then find  $\tan \theta, \sin \theta$  and  $\sec \theta$ .

**Solution :** Given  $\tan \theta + \sec \theta = 1.5$

$$\therefore \tan \theta + \sec \theta = \frac{3}{2} \quad \dots (1)$$

Now  $\sec^2 \theta - \tan^2 \theta = 1$

$$\therefore (\sec \theta + \tan \theta)(\sec \theta - \tan \theta) = 1$$

$$\therefore \frac{3}{2} (\sec \theta - \tan \theta) = 1$$

$$\therefore (\sec \theta - \tan \theta) = \frac{2}{3} \quad \dots (2)$$

From (1) and (2), we get,  $2 \sec \theta = \frac{13}{6}$

$$\therefore \sec \theta = \frac{13}{12} \text{ and } \cos \theta = \frac{12}{13}$$

$$\therefore \tan \theta = \frac{5}{12} \text{ and } \sin \theta = \frac{5}{13}$$

**Ex. 10** Prove that

$$\frac{\sin \theta}{1 - \cos \theta} + \frac{\tan \theta}{1 + \cos \theta} = \sec \theta \operatorname{cosec} \theta + \cot \theta$$

**Solution :** LHS =  $\frac{\sin \theta}{1 - \cos \theta} + \frac{\tan \theta}{1 + \cos \theta}$

$$= \frac{\sin \theta(1 + \cos \theta) + \tan \theta(1 - \cos \theta)}{(1 - \cos \theta)(1 + \cos \theta)}$$

$$= \frac{\sin \theta + \sin \theta \cos \theta + \tan \theta - \tan \theta \cos \theta}{1 - \cos^2 \theta}$$

$$= \frac{\sin \theta + \sin \theta \cos \theta + \tan \theta - \tan \theta \cos \theta}{\sin^2 \theta}$$

$$= \frac{\sin \theta}{\sin^2 \theta} + \frac{\sin \theta \cos \theta}{\sin^2 \theta} + \frac{\tan \theta}{\sin^2 \theta} - \frac{\tan \theta \cos \theta}{\sin^2 \theta}$$

$$= \frac{\sin \theta}{\sin^2 \theta} + \frac{\sin \theta \cos \theta}{\sin^2 \theta} + \frac{\tan \theta}{\sin^2 \theta} - \frac{\sin \theta}{\sin^2 \theta}$$

$$= \frac{\sin \theta \cos \theta}{\sin^2 \theta} + \frac{\tan \theta}{\sin^2 \theta}$$

$$= \frac{\cos \theta}{\sin \theta} + \frac{1}{\sin \theta \cos \theta} = \cot \theta + \operatorname{cosec} \theta \sec \theta$$

$$= \sec \theta \operatorname{cosec} \theta + \cot \theta = \text{RHS}$$

**Ex. 11** Prove that

$$\frac{\sec \theta - \tan \theta}{\sec \theta + \tan \theta} = 1 - 2 \sec \theta \tan \theta + 2 \tan^2 \theta$$

$$\begin{aligned}
 \text{Solution : LHS} &= \frac{\sec \theta - \tan \theta}{\sec \theta + \tan \theta} \\
 &= \frac{\sec \theta - \tan \theta}{\sec \theta + \tan \theta} \times \frac{\sec \theta - \tan \theta}{\sec \theta - \tan \theta} \\
 &= \frac{(\sec \theta - \tan \theta)^2}{\sec^2 \theta - \tan^2 \theta} \\
 &= \frac{\sec^2 \theta + \tan^2 \theta - 2 \sec \theta \tan \theta}{1} \\
 &= 1 + \tan^2 \theta + \tan^2 \theta - 2 \sec \theta \tan \theta \\
 &= 1 - 2 \sec \theta \tan \theta + 2 \tan^2 \theta = \text{RHS}
 \end{aligned}$$

**Ex.12** Prove that  $(\sec A - \tan A)^2 = \frac{1 - \sin A}{1 + \sin A}$

$$\begin{aligned}
 \text{Solution : LHS} &= (\sec A - \tan A)^2 \\
 &= \sec^2 A + \tan^2 A - 2 \sec A \tan A \\
 &= \frac{1}{\cos^2 A} + \frac{\sin^2 A}{\cos^2 A} - 2 \frac{\sin A}{\cos A \cos A} \\
 &= \frac{1 + \sin^2 A - 2 \sin A}{\cos^2 A} \\
 &= \frac{(1 - \sin A)^2}{1 - \sin^2 A} = \frac{1 - \sin A}{1 + \sin A} = \text{RHS}
 \end{aligned}$$



### Let's Learn

**2.2.4 Polar Co-ordinate system :** Consider O as the origin and OX as X-axis. P (x,y) is any point in the plane. Let OP = r and  $m\angle XOP = \theta$ . Then the ordered pair (r,  $\theta$ ) determines the position of point P. Here (r,  $\theta$ ) are called the polar coordinates of P. The fixed point O is called the Pole and the fixed ray OX or X-axis is called as the polar axis.

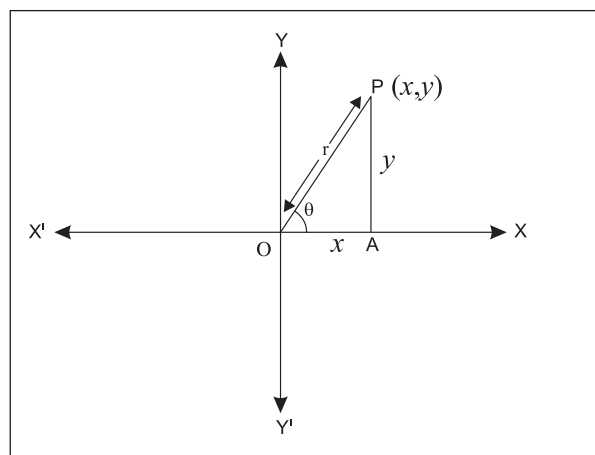

**Fig. 2.24**

The Cartesian co-ordinates of the point P(r,  $\theta$ ) will be given by relations :

$$x = r \cos \theta \quad \text{and} \quad y = r \sin \theta$$

From these relations we get

$$r = \sqrt{x^2 + y^2} \quad \text{and} \quad \tan \theta = \frac{y}{x}$$

### SOLVED EXAMPLE

**Ex.** Find the polar co-ordinates of the point whose Cartesian coordinates are (3,3).

**Solution :** Here  $x = 3$  and  $y = 3$

To find r and  $\theta$ .

$$r = \sqrt{x^2 + y^2} \quad \text{and} \quad \tan \theta = \frac{y}{x}$$

$$r = \sqrt{x^2 + y^2} = \sqrt{3^2 + 3^2} = \sqrt{18} = 3\sqrt{2}$$

$$\therefore r = 3\sqrt{2}$$

Since point P lies in the first quadrant,  $\theta$  is an angle in the first quadrant.

$$\tan \theta = \frac{y}{x} = \frac{3}{3} = 1 \quad \therefore \theta = 45^\circ$$

Polar co-ordinates of P are  $(r, \theta) = (3\sqrt{2}, 45^\circ)$

**EXERCISE 2.2**

- 1) If  $2 \sin A = 1 = \sqrt{2} \cos B$  and  $\frac{\pi}{2} < A < \pi$ ,  $\frac{3\pi}{2} < B < 2\pi$ , then find the value of  $\frac{\tan A + \tan B}{\cos A - \cos B}$
- 2) If  $\frac{\sin A}{3} = \frac{\sin B}{4} = \frac{1}{5}$  and A, B are angles in the second quadrant then prove that  $4\cos A + 3\cos B = -5$ .
- 3) If  $\tan \theta = \frac{1}{2}$ , evaluate  $\frac{2\sin \theta + 3\cos \theta}{4\cos \theta + 3\sin \theta}$
- 4) Eliminate  $\theta$  from the following :
  - i)  $x = 3\sec \theta, y = 4\tan \theta$
  - ii)  $x = 6\operatorname{cosec} \theta, y = 8\cot \theta$
  - iii)  $x = 4\cos \theta - 5\sin \theta, y = 4\sin \theta + 5\cos \theta$
  - iv)  $x = 5 + 6\operatorname{cosec} \theta, y = 3 + 8\cot \theta$
  - v)  $2x = 3 - 4\tan \theta, 3y = 5 + 3\sec \theta$
- 5) If  $2\sin^2 \theta + 3\sin \theta = 0$ , find the permissible values of  $\cos \theta$ .
- 6) If  $2\cos^2 \theta - 11\cos \theta + 5 = 0$  then find possible values of  $\cos \theta$ .
- 7) Find the acute angle  $\theta$  such that  $2\cos^2 \theta = 3\sin \theta$
- 8) Find the acute angle  $\theta$  such that  $5\tan^2 \theta + 3 = 9\sec \theta$
- 9) Find  $\sin \theta$  such that  $3\cos \theta + 4\sin \theta = 4$
- 10) If  $\operatorname{cosec} \theta + \cot \theta = 5$ , then evaluate  $\sec \theta$ .
- 11) If  $\cot \theta = \frac{3}{4}$  and  $\pi < \theta < \frac{3\pi}{4}$  then find the value of  $4\operatorname{cosec} \theta + 5\cos \theta$ .
- 12) Find the Cartesian co-ordinates of points whose polar coordinates are :
  - i)  $(3, 90^\circ)$
  - ii)  $(1, 180^\circ)$
- 15) Find the polar co-ordinates of points whose Cartesian co-ordinates are :
  - i)  $(5, 5)$
  - ii)  $(1, \sqrt{3})$
  - iii)  $(-1, -1)$
  - iv)  $(-\sqrt{3}, 1)$
- 16) Find the value of
  - i)  $\sin \frac{19\pi^c}{3}$
  - ii)  $\cos 1140^\circ$
  - iii)  $\cot \frac{25\pi^c}{3}$
- 17) Prove the following identities:
  - i)  $(1 + \tan^2 A) + \left(1 + \frac{1}{\tan^2 A}\right) = \frac{1}{\sin^2 A - \sin^4 A}$
  - ii)  $(\cos^2 A - 1)(\cot^2 A + 1) = -1$
  - iii)  $(\sin \theta + \sec \theta)^2 + (\cos \theta + \operatorname{cosec} \theta)^2 = (1 + \operatorname{cosec} \theta \sec \theta)^2$
  - iv)  $(1 + \cot \theta - \operatorname{cosec} \theta)(1 + \tan \theta + \sec \theta) = 2$
  - v)  $\frac{\tan^3 \theta}{1 + \tan^2 \theta} + \frac{\cot^3 \theta}{1 + \cot^2 \theta} = \sec \theta \operatorname{cosec} \theta - 2 \sin \theta \cos \theta$
  - vi)  $\frac{1}{\sec \theta + \tan \theta} - \frac{1}{\cos \theta} = \frac{1}{\cos \theta} - \frac{1}{\sec \theta - \tan \theta}$
  - vii)  $\frac{\sin \theta}{1 + \cos \theta} + \frac{1 + \cos \theta}{\sin \theta} = 2 \operatorname{cosec} \theta$
  - viii)  $\frac{\tan \theta}{\sec \theta - 1} = \frac{\sec \theta + 1}{\tan \theta}$
  - ix)  $\frac{\cot \theta}{\operatorname{cosec} \theta - 1} = \frac{\operatorname{cosec} \theta + 1}{\cot \theta}$
  - x)  $(\sec A + \cos A)(\sec A - \cos A) = \tan^2 A + \sin^2 A$
  - xi)  $1 + 3\operatorname{cosec}^2 \theta \cdot \cot^2 \theta + \cot^6 \theta = \operatorname{cosec}^6 \theta$
  - xii)  $\frac{1 - \sec \theta + \tan \theta}{1 + \sec \theta - \tan \theta} = \frac{\sec \theta + \tan \theta - 1}{\sec \theta + \tan \theta + 1}$



**Let's Remember**

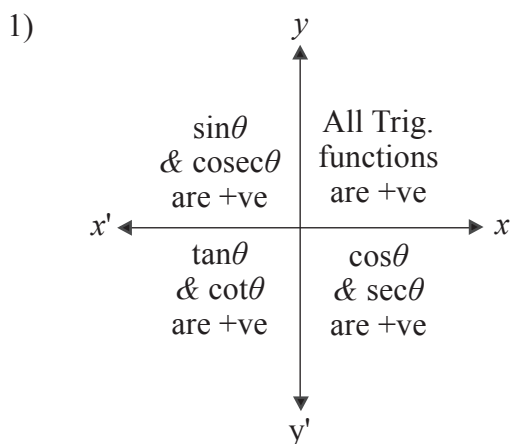

**Fig. 2.25**

- 2) All trigonometric functions are positive for  $\theta$  in the first quadrant.
- 3) Only  $\sin\theta$  is positive;  $\cos\theta$  and  $\tan\theta$  are negative for  $\theta$  in the second quadrant.
- 4) Only  $\tan\theta$  is positive  $\sin\theta$  and  $\cos\theta$  are negative for  $\theta$  in the third quadrant.
- 5) Only  $\cos\theta$  is positive;  $\sin\theta$  and  $\tan\theta$  are negative for  $\theta$  in the fourth quadrant.
- 6) Signs of  $\operatorname{cosec}\theta$ ,  $\sec\theta$  and  $\cot\theta$  are same as signs of  $\sin\theta$ ,  $\cos\theta$  and  $\tan\theta$  respectively.
- 7) The fundamental identities of trigonometric functions.
  - 1)  $\sin^2 \theta + \cos^2 \theta = 1$
  - 2)  $1 + \tan^2 \theta = \sec^2 \theta$ , If  $\theta \neq \frac{\pi}{2}$
  - 3)  $1 + \cot^2 \theta = \operatorname{cosec}^2 \theta$ , if  $\theta \neq 0$

**8) Domain, Range and Periodicity of Trigonometric functions**

Trigonometric functions	Domain	Range	Period
$\sin\theta$	$\mathbb{R}$	$[-1, 1]$	$2\pi$
$\cos\theta$	$\mathbb{R}$	$[-1, 1]$	$2\pi$
$\tan\theta$	$\mathbb{R} - \{(2n+1)\frac{\pi}{2} : n \in \mathbb{I}\}$	$\mathbb{R}$	$\pi$
$\operatorname{cosec}\theta$	$\mathbb{R} - \{n\pi : n \in \mathbb{I}\}$	$\mathbb{R} - (-1, 1)$	$2\pi$
$\sec\theta$	$\mathbb{R} - \{(2n+1)\frac{\pi}{2} : n \in \mathbb{I}\}$	$\mathbb{R} - (-1, 1)$	$2\pi$
$\cot\theta$	$\mathbb{R} - \{n\pi : n \in \mathbb{I}\}$	$\mathbb{R}$	$\pi$

**9) Polar Co-ordinate system :** The Cartesian co-ordinates of the point P(r,  $\theta$ ) are given by the relations :

$$x = r \cos\theta \quad \text{and} \quad y = r \sin\theta$$

where,  $r = \sqrt{x^2 + y^2}$  and  $\tan\theta = \frac{y}{x}$

**MISCELLANEOUS EXERCISE - 2**

**I) Select the correct option from the given alternatives.**

- 1) The value of the expression  $\cos 1^\circ \cdot \cos 2^\circ \cdot \cos 3^\circ \cdot \dots \cdot \cos 179^\circ =$ 

A) -1      B) 0      C)  $\frac{1}{\sqrt{2}}$       D) 1
- 2)  $\frac{\tan A}{1 + \sec A} + \frac{1 + \sec A}{\tan A}$  is equal to
 

A)  $2\operatorname{cosec} A$       B)  $2\sec A$   
 C)  $2\sin A$       D)  $2\cos A$
- 3) If  $\alpha$  is a root of  $25\cos^2\theta + 5\cos\theta - 12 = 0$ ,  $\frac{\pi}{2} < \alpha < \pi$  then  $\sin 2\alpha$  is equal to :
 

A)  $-\frac{24}{25}$       B)  $-\frac{13}{18}$       C)  $\frac{13}{18}$       D)  $\frac{24}{25}$

- 4) If  $\theta = 60^\circ$ , then  $\frac{1 + \tan^2 \theta}{2 \tan \theta}$  is equal to  
 A)  $\frac{\sqrt{3}}{2}$     B)  $\frac{2}{\sqrt{3}}$     C)  $\frac{1}{\sqrt{3}}$     D)  $\sqrt{3}$
- 5) If  $\sec \theta = m$  and  $\tan \theta = n$ , then  $\frac{1}{m} \left\{ (m+n) + \frac{1}{(m+n)} \right\}$  is equal to  
 A) 2    B)  $mn$     C)  $2m$     D)  $2n$
- 6) If  $\operatorname{cosec} \theta + \cot \theta = \frac{5}{2}$ , then the value of  $\tan \theta$  is  
 A)  $\frac{14}{25}$     B)  $\frac{20}{21}$     C)  $\frac{21}{20}$     D)  $\frac{15}{16}$
- 7)  $1 - \frac{\sin^2 \theta}{1 + \cos \theta} + \frac{1 + \cos \theta}{\sin \theta} - \frac{\sin \theta}{1 - \cos \theta}$  equals  
 A) 0    B) 1    C)  $\sin \theta$     D)  $\cos \theta$
- 8) If  $\operatorname{cosec} \theta - \cot \theta = q$ , then the value of  $\cot \theta$  is  
 A)  $\frac{2q}{1+q^2}$     B)  $\frac{2q}{1-q^2}$     C)  $\frac{1-q^2}{2q}$     D)  $\frac{1+q^2}{2q}$
- 9) The cotangent of the angles  $\frac{\pi}{3}$ ,  $\frac{\pi}{4}$  and  $\frac{\pi}{6}$  are in  
 A) A.P.    B) G.P.  
 C) H.P.    D) Not in progression
- 10) The value of  $\tan 1^\circ \cdot \tan 2^\circ \cdot \tan 3^\circ \dots \tan 89^\circ$  is equal to  
 A) -1    B) 1    C)  $\frac{\pi}{2}$     D) 2
- 3) State the quadrant in which  $\theta$  lies if  
 i)  $\tan \theta < 0$  and  $\sec \theta > 0$   
 ii)  $\sin \theta < 0$  and  $\cos \theta < 0$   
 iii)  $\sin \theta > 0$  and  $\tan \theta < 0$
- 4) Which is greater  $\sin(1856^\circ)$  or  $\sin(2006^\circ)$  ?
- 5) Which of the following is positive ?  
 $\sin(-310^\circ)$  or  $\sin(310^\circ)$
- 6) Show that  $1 - 2\sin \theta \cos \theta \geq 0$  for all  $\theta \in R$
- 7) Show that  $\tan^2 \theta + \cot^2 \theta \geq 2$  for all  $\theta \in R$
- 8) If  $\sin \theta = \frac{x^2 - y^2}{x^2 + y^2}$  then find the values of  $\cos \theta$ ,  $\tan \theta$  in terms of  $x$  and  $y$ .
- 9) If  $\sec \theta = \sqrt{2}$  and  $\frac{3\pi}{2} < \theta < 2\pi$  then evaluate  

$$\frac{1 + \tan \theta + \operatorname{cosec} \theta}{1 + \cot \theta - \operatorname{cosec} \theta}$$

10) Prove the following:

- i)  $\sin^2 A \cos^2 B + \cos^2 A \sin^2 B + \cos^2 A \cos^2 B + \sin^2 A \sin^2 B = 1$
- ii) 
$$\frac{(1 + \cot \theta + \tan \theta)(\sin \theta - \cos \theta)}{\sec^3 \theta - \operatorname{cosec}^3 \theta} = \sin^2 \theta \cos^2 \theta$$
- iii) 
$$\left( \tan \theta + \frac{1}{\cos \theta} \right)^2 + \left( \tan \theta - \frac{1}{\cos \theta} \right)^2 = 2 \left( \frac{1 + \sin^2 \theta}{1 - \sin^2 \theta} \right)$$
- iv)  $2 \sec^2 \theta - \sec^4 \theta - 2 \operatorname{cosec}^2 \theta + \operatorname{cosec}^4 \theta = \cot^4 \theta - \tan^4 \theta$
- v)  $\sin^4 \theta + \cos^4 \theta = 1 - 2 \sin^2 \theta \cos^2 \theta$
- vi)  $2(\sin^6 \theta + \cos^6 \theta) - 3(\sin^4 \theta + \cos^4 \theta) + 1 = 0$

II) Answer the following.

- 1) Find the trigonometric functions of :  
 $90^\circ$ ,  $120^\circ$ ,  $225^\circ$ ,  $240^\circ$ ,  $270^\circ$ ,  $315^\circ$ ,  $-120^\circ$ ,  
 $-150^\circ$ ,  $-180^\circ$ ,  $-210^\circ$ ,  $-300^\circ$ ,  $-330^\circ$
- 2) State the signs of  
 i)  $\operatorname{cosec} 520^\circ$     ii)  $\cot 1899^\circ$     iii)  $\sin 986^\circ$

vii)  $\cos^4\theta - \sin^4\theta + 1 = 2\cos^2\theta$

viii)  $\sin^4\theta + 2\sin^2\theta \cdot \cos^2\theta = 1 - \cos^4\theta$

ix)  $\frac{\sin^3\theta + \cos^3\theta}{\sin\theta + \cos\theta} + \frac{\sin^3\theta - \cos^3\theta}{\sin\theta - \cos\theta} = 2$

x)  $\tan^2\theta - \sin^2\theta = \sin^4\theta \sec^2\theta$

xi)  $(\sin\theta + \operatorname{cosec}\theta)^2 + (\cos\theta + \sec\theta)^2 = \tan^2\theta + \cot^2\theta + 7$

xii)  $\sin^8\theta - \cos^8\theta = (\sin^2\theta - \cos^2\theta)(1 - 2\sin^2\theta \cos^2\theta)$

xiii)  $\sin^6A + \cos^6A = 1 - 3\sin^2A + 3\sin^4A$

xiv)  $(1 + \tan A \cdot \tan B)^2 + (\tan A - \tan B)^2 = \sec^2 A \cdot \sec^2 B$

xv)  $\frac{1 + \cot\theta + \operatorname{cosec}\theta}{1 - \cot\theta + \operatorname{cosec}\theta} = \frac{\operatorname{cosec}\theta + \cot\theta - 1}{\cot\theta - \operatorname{cosec}\theta + 1}$

xvi)  $\frac{\tan\theta + \sec\theta - 1}{\tan\theta + \sec\theta + 1} = \frac{\tan\theta}{\sec\theta + 1}$

xvii)  $\frac{\operatorname{cosec}\theta + \cot\theta - 1}{\operatorname{cosec}\theta + \cot\theta + 1} = \frac{1 - \sin\theta}{\cos\theta}$

xviii)  $\frac{\operatorname{cosec}\theta + \cot\theta + 1}{\cot\theta + \operatorname{cosec}\theta - 1} = \frac{\cot\theta}{\operatorname{cosec}\theta - 1}$



# 3 Trigonometry - II

## Let's Study

- Trigonometric functions of sum and difference of angles.
- Trigonometric functions of allied angles.
- Trigonometric functions of multiple angles.
- Factorization formulae.
- Trigonometric functions of angles of a triangle.

## Let's Recall

In the previous chapter we have studied trigonometric functions in different quadrants.

**3.1 Compound angle :** Compound angles are sum or difference of given angles.

Following are theorems about trigonometric functions of sum and difference of two angles.

## Let's Derive

**Theorem : 1)** For any two angles A and B,  $\cos(A-B) = \cos A \cos B + \sin A \sin B$

### Proof :

Draw a unit standard circle. Take points P and Q on the circle so that OP makes an angle A with positive X-axis and OQ makes an angle B with positive X-axis.

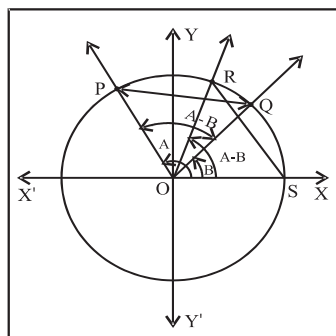

**Fig. 3.1**

$\therefore \angle XOP = A, \angle XOQ = B$ . From figure  $OP = OQ = 1$

$\therefore$  Co-ordinates of P and Q are  $(\cos A, \sin A)$  and  $(\cos B, \sin B)$  respectively .

$$\begin{aligned} \therefore d(PQ) &= \sqrt{(\cos A - \cos B)^2 + (\sin A - \sin B)^2} \\ &= \sqrt{\cos^2 A - 2\cos A \cos B + \cos^2 B + \sin^2 A - 2\sin A \sin B + \sin^2 B} \\ &= \sqrt{(\cos^2 A + \sin^2 A) + (\cos^2 B + \sin^2 B) - 2(\cos A \cos B + \sin A \sin B)} \\ &= \sqrt{1 + 1 - 2(\cos A \cos B + \sin A \sin B)} \\ &= \sqrt{2 - 2(\cos A \cos B + \sin A \sin B)} \end{aligned}$$

$$[d(PQ)]^2 = 2 - 2(\cos A \cos B + \sin A \sin B) \dots(1)$$

Now consider OQ as new X-axis. Draw new Y-axis perpendicular to it.

$\therefore \angle QOP = A - B$

$\therefore$  Co-ordinates of P and Q are  $(\cos(A-B), \sin(A-B))$

and  $(1, 0)$  respectively.

$P \equiv (\cos(A-B), \sin(A-B)), Q \equiv (1, 0)$

$$\begin{aligned} \therefore d(PQ) &= \sqrt{[\cos(A-B) - 1]^2 + [\sin(A-B) - 0]^2} \\ &= \sqrt{\cos^2(A-B) - 2\cos(A-B) + 1 + \sin^2(A-B)} \\ &= \sqrt{\cos^2(A-B) + \sin^2(A-B) + 1 - 2\cos(A-B)} \\ &= \sqrt{1 + 1 - 2\cos(A-B)} \\ &= \sqrt{2 - 2\cos(A-B)} \\ [d(PQ)]^2 &= 2 - 2\cos(A-B) \dots(2) \end{aligned}$$

From equation (1) and (2) we get

$$2-2 \cos (A-B)=2-2(\cos A \cos B+\sin A \sin B)$$

$$\therefore -2 \cos (A-B)=-2(\cos A \cos B+\sin A \sin B)$$

$$\therefore \cos (A-B)=\cos A \cos B+\sin A \sin B$$

**Theorem : 2)** For any two angles A and B ,

$$\cos (A+B)=\cos A \cos B-\sin A \sin B$$

**Proof :** We know that

$$\cos (x-y)=\cos x \cos y+\sin x \sin y$$

Put  $x=A, y=-B$  we get

$$\cos (A+B)=\cos A \cos B+\sin A (-\sin B)$$

$$\therefore \cos (-\theta)=\cos \theta, \sin (-\theta)=-\sin \theta$$

$$\therefore \cos (A+B)=\cos A \cos B-\sin A \sin B$$

**Results :**

$$1) \cos \left(\frac{\pi}{2}-\theta\right)=\sin \theta$$

**Proof :** We know that

$$\cos (x-y)=\cos x \cos y+\sin x \sin y$$

Put  $x=\frac{\pi}{2}, y=\theta$  we get

$$\cos \left(\frac{\pi}{2}-\theta\right)=\cos \frac{\pi}{2} \cos \theta+\sin \frac{\pi}{2} \sin \theta$$

$$=0 \cdot \cos \theta+1 \cdot \sin \theta$$

$$=\sin \theta$$

$$\therefore \cos \left(\frac{\pi}{2}-\theta\right)=\sin \theta$$

**Similarly**

$$2) \cos \left(\frac{\pi}{2}+\theta\right)=-\sin \theta$$

$$3) \sin \left(\frac{\pi}{2}-\theta\right)=\cos \theta$$

$$4) \sin \left(\frac{\pi}{2}+\theta\right)=\cos \theta$$

$$5) \tan \left(\frac{\pi}{2}-\theta\right)=\frac{\sin \left(\frac{\pi}{2}-\theta\right)}{\cos \left(\frac{\pi}{2}-\theta\right)}=\frac{\cos \theta}{\sin \theta}=\cot \theta$$

$$6) \tan \left(\frac{\pi}{2}+\theta\right)=-\cot \theta$$

**Theorem : 3)** For any two angles A and B,

$$\sin (A-B)=\sin A \cos B-\cos A \sin B$$

**Proof :** We know that  $\cos \left(\frac{\pi}{2}-\theta\right)=\sin \theta$

Putting  $\theta=A-B$ , we get

$$\sin (A-B)=\cos \left[\frac{\pi}{2}-(A-B)\right]$$

$$=\cos \left(\left(\frac{\pi}{2}-A\right)+B\right)$$

$$=\cos \left(\frac{\pi}{2}-A\right) \cos B-\sin \left(\frac{\pi}{2}-A\right) \sin B$$

$$\therefore \sin (A-B)=\sin A \cos B-\cos A \sin B$$

$$\left[\because \cos \left(\frac{\pi}{2}-\theta\right)=\sin \theta, \sin \left(\frac{\pi}{2}-\theta\right)=\cos \theta\right]$$

**Theorem : 4)** For any two angles A and B,

$$\sin (A+B)=\sin A \cos B+\cos A \sin B \quad [\text{verify}]$$

**Theorem : 5)** For any two angles A and B,

$$\tan (A+B)=\frac{\tan A+\tan B}{1-\tan A \tan B}$$

**Proof :** Consider  $\tan (A+B)=\frac{\sin (A+B)}{\cos (A+B)}$

$$=\frac{\frac{\sin A \cos B+\cos A \sin B}{\cos A \cos B}}{\frac{\cos A \cos B-\sin A \sin B}{\cos A \cos B}} \quad (\text{dividing numerator and denominator by } \cos A \cos B)$$

and denominator by  $\cos A \cos B$ )

$$=\frac{\frac{\sin A \cos B}{\cos A \cos B}+\frac{\cos A \sin B}{\cos A \cos B}}{\frac{\cos A \cos B}{\cos A \cos B}-\frac{\sin A \sin B}{\cos A \cos B}}$$

$$\begin{aligned} & \frac{\sin A}{\cos A} + \frac{\sin B}{\cos B} \\ = & 1 - \frac{\sin A}{\cos A} \frac{\sin B}{\cos B} \\ = & \frac{\tan A + \tan B}{1 - \tan A \tan B} \\ \therefore \tan (A+B) &= \frac{\tan A + \tan B}{1 - \tan A \tan B} \end{aligned}$$

**Theorem : 6)** For any two angles A and B,

$$\tan (A-B) = \frac{\tan A - \tan B}{1 + \tan A \tan B} \quad (\text{Activity})$$

**Results :**

- 1) If none of the angles A, B and (A+B) is a multiple of  $\pi$

$$\text{then, } \cot (A+B) = \frac{\cot A \cot B - 1}{\cot B + \cot A}$$

- 2) If none of the angles A, B and (A-B) is a multiple of  $\pi$

$$\text{then, } \cot (A-B) = \frac{\cot A \cot B + 1}{\cot B - \cot A}$$

### SOLVED EXAMPLES

**Ex. 1)** Find the value of  $\cos 15^\circ$

**Solution :**  $\cos 15^\circ = \cos(45^\circ - 30^\circ)$

$$= \cos 45^\circ \cos 30^\circ + \sin 45^\circ \sin 30^\circ$$

$$= \frac{1}{\sqrt{2}} \frac{\sqrt{3}}{2} + \frac{1}{\sqrt{2}} \frac{1}{2}$$

$$= \frac{\sqrt{3}}{2\sqrt{2}} + \frac{1}{2\sqrt{2}}$$

$$= \frac{\sqrt{3} + 1}{2\sqrt{2}}$$

**Ex. 2)** Find the value of  $\tan \frac{13\pi^c}{12}$

**Solution :**  $\tan \frac{13\pi^c}{12} = \tan \left( \pi^c + \frac{\pi^c}{12} \right)$

$$= \frac{\tan \pi + \tan \frac{\pi}{12}}{1 - \tan \pi \tan \frac{\pi}{12}}$$

$$= \frac{0 + \tan \frac{\pi}{12}}{1 + 0 \times \tan \frac{\pi}{12}}$$

$$= \tan \frac{\pi}{12}$$

$$= \tan \left( \frac{\pi}{4} - \frac{\pi}{6} \right)$$

$$= \frac{\tan \frac{\pi}{4} - \tan \frac{\pi}{6}}{1 + \tan \frac{\pi}{4} \tan \frac{\pi}{6}}$$

$$= \frac{1 - \frac{1}{\sqrt{3}}}{1 + 1 \times \frac{1}{\sqrt{3}}}$$

$$= 2 - \sqrt{3}$$

**Ex. 3)** Show that  $\frac{\sin(x+y)}{\sin(x-y)} = \frac{\tan x + \tan y}{\tan x - \tan y}$

**Solution :** L.H.S. =  $\frac{\sin(x+y)}{\sin(x-y)}$

$$= \frac{\sin x \cos y + \cos x \sin y}{\sin x \cos y - \cos x \sin y}$$

(dividing numerator and denominator by  $\cos x \cos y$ )

$$= \frac{\frac{\sin x}{\cos x} + \frac{\sin y}{\cos y}}{\frac{\sin x}{\cos x} - \frac{\sin y}{\cos y}}$$

$$= \frac{\tan x + \tan y}{\tan x - \tan y}$$

$$= \text{R.H.S.}$$

**Ex. 4)** Show that :  $\tan 3x \tan 2x \tan x = \tan 3x - \tan 2x - \tan x$

**Solution :**  $\tan (3x) = \tan (2x+x)$

$$\therefore \tan (3x) = \frac{\tan 2x + \tan x}{1 - \tan 2x \tan x}$$

$$\therefore \tan 3x [1 - \tan 2x \tan x] = \tan 2x + \tan x$$

$$\therefore \tan 3x - \tan 3x \tan 2x \tan x = \tan 2x + \tan x$$

$$\therefore \tan 3x - \tan 2x - \tan x = \tan 3x \tan 2x \tan x$$

$$\therefore \tan 3x \tan 2x \tan x = \tan 3x - \tan 2x - \tan x$$

**Ex. 5)** Show that  $\cos\left(\frac{\pi}{4} + x\right) + \cos\left(\frac{\pi}{4} - x\right)$   
 $= \sqrt{2} \cos x$

**Solution :** L.H.S. =  $\cos\left(\frac{\pi}{4} + x\right) + \cos\left(\frac{\pi}{4} - x\right)$

$$= \cos \frac{\pi}{4} \cos x - \sin \frac{\pi}{4} \sin x + \cos \frac{\pi}{4} \cos x$$

$$+ \sin \frac{\pi}{4} \sin x$$

$$= \frac{1}{\sqrt{2}} \cos x + \frac{1}{\sqrt{2}} \cos x$$

$$= \frac{2}{\sqrt{2}} \cos x = \sqrt{2} \cos x = \text{R. H.S.}$$

**Ex. 6)** If  $\tan A - \tan B = x$  and  $\cot B - \cot A = y$   
 then show that

$$\cot (A-B) = \frac{1}{x} + \frac{1}{y}$$

**Solution :**  $\cot B - \cot A = y$

$$\therefore \frac{1}{\tan B} - \frac{1}{\tan A} = y$$

$$\therefore \frac{\tan A - \tan B}{\tan A \tan B} = y$$

$$\therefore \frac{x}{\tan A \tan B} = y$$

$$\therefore \tan A \tan B = \frac{x}{y}$$

$$\text{Now } \cot (A-B) = \frac{1}{\tan (A-B)}$$

$$= \frac{1 + \tan A \tan B}{\tan A - \tan B}$$

$$= \frac{1 + \frac{x}{y}}{\frac{x}{y}} = \frac{x+y}{xy} = \frac{1}{y} + \frac{1}{x}$$

$$\therefore \cot (A-B) = \frac{1}{y} + \frac{1}{x}$$

**Ex. 7)** If

$$\tan \alpha = \frac{1}{\sqrt{x(x^2+x+1)}}, \tan \beta = \frac{\sqrt{x}}{\sqrt{x^2+x+1}} \text{ and } \tan \gamma = \sqrt{x^{-3} + x^{-2} + x^{-1}}$$

then show that

$$\alpha + \beta = \gamma$$

**Solution :** We know that

$$\tan(\alpha + \beta) = \frac{\tan \alpha + \tan \beta}{1 - \tan \alpha \tan \beta}$$

$$\therefore \tan (\alpha + \beta) =$$

$$= \left[ \frac{\frac{1}{\sqrt{x(x^2+x+1)}} + \frac{\sqrt{x}}{\sqrt{x^2+x+1}}}{1 - \frac{1}{\sqrt{x(x^2+x+1)}} \cdot \frac{\sqrt{x}}{\sqrt{x^2+x+1}}} \right]$$

$$= \frac{(x+1)\sqrt{x^2+x+1}}{\sqrt{x} \cdot x(x+1)}$$

$$= \sqrt{\frac{x^2}{x^3} + \frac{x}{x^3} + \frac{1}{x^3}}$$

$$= \sqrt{x^{-1} + x^{-2} + x^{-3}}$$

$$= \tan \gamma$$

$$\therefore \alpha + \beta = \gamma$$

**Ex. 8)** If  $\sin A + \sin B = x$  and  $\cos A + \cos B = y$  then

show that  $\sin(A+B) = \frac{2xy}{x^2 + y^2}$

**Solution :**

$$y^2 + x^2 = (\cos A + \cos B)^2 + (\sin A + \sin B)^2$$

$$= \cos^2 A + 2\cos A \cos B + \cos^2 B + \sin^2 A + \sin^2 B + 2\sin A \sin B$$

$$y^2 + x^2 = (\cos^2 A + \sin^2 A) + (\cos^2 B + \sin^2 B) + 2(\cos A \cos B + \sin A \sin B)$$

$$= 1 + 1 + 2\cos(A-B)$$

$$\therefore x^2 + y^2 = 2 + 2\cos(A-B) \quad \dots\dots\dots (I)$$

$$y^2 - x^2 = (\cos A + \cos B)^2 - (\sin A + \sin B)^2$$

$$= (\cos^2 A - \sin^2 A) + (\cos^2 B - \sin^2 B) + 2[\cos A \cos B - \sin A \sin B]$$

$$= \cos 2A + \cos 2B + 2 \cos(A+B)$$

$$= 2\cos\left[\frac{2A+2B}{2}\right] \cdot \cos\left[\frac{2A-2B}{2}\right]$$

$$+ 2\cos(A+B)$$

$$= 2\cos(A+B) \cos(A-B) + 2\cos(A+B)$$

$$= \cos(A+B) [2\cos(A-B) + 2] \quad [\text{from (I)}]$$

$$y^2 - x^2 = \cos(A+B) (x^2 + y^2)$$

$$\therefore \frac{y^2 - x^2}{x^2 + y^2} = \cos(A+B)$$

$$\therefore \sin(A+B) =$$

$$\therefore \sin(A+B) = \sqrt{1 - \left(\frac{y^2 - x^2}{x^2 + y^2}\right)^2}$$

$$= \sqrt{\frac{(y^2 + x^2)^2 - (y^2 - x^2)^2}{(y^2 + x^2)^2}}$$

$$= \sqrt{\frac{y^4 + 2x^2y^2 + x^4 - y^4 - 2x^2y^2 - x^4}{(x^2 + y^2)^2}}$$

$$= \sqrt{\frac{4x^2y^2}{(x^2 + y^2)^2}}$$

$$= \frac{2xy}{x^2 + y^2}$$

**EXERCISE 3.1**

1) Find the values of

- i)  $\sin 15^\circ$       ii)  $\cos 75^\circ$       iii)  $\tan 105^\circ$
- iv)  $\cot 225^\circ$

2) Prove the following.

i)  $\cos\left(\frac{\pi}{2} - x\right) \cos\left(\frac{\pi}{2} - y\right) - \sin\left(\frac{\pi}{2} - x\right) \sin\left(\frac{\pi}{2} - y\right) = -\cos(x+y)$

ii)  $\tan\left(\frac{\pi}{4} + \theta\right) = \frac{1 - \tan \theta}{1 + \tan \theta}$

iii)  $\left(\frac{1 + \tan x}{1 - \tan x}\right)^2 = \frac{\tan\left(\frac{\pi}{4} + x\right)}{\tan\left(\frac{\pi}{4} - x\right)}$

iv)  $\sin[(n+1)A] \cdot \sin[(n+2)A] + \cos[(n+1)A] \cdot \cos[(n+2)A] = \cos A$

v)  $\sqrt{2} \cos\left(\frac{\pi}{4} - A\right) = \cos A + \sin A$

vi)  $\frac{\cos(x-y)}{\cos(x+y)} = \frac{\cot x \cot y + 1}{\cot x \cot y - 1}$

vii)  $\cos(x+y) \cdot \cos(x-y) = \cos^2 y - \sin^2 x$

viii)  $\frac{\tan 5A - \tan 3A}{\tan 5A + \tan 3A} = \frac{\sin 2A}{\sin 8A}$

ix)  $\tan 8\theta - \tan 5\theta - \tan 3\theta = \tan 8\theta \tan 5\theta \tan 3\theta$

x)  $\tan 50^\circ = \tan 40^\circ + 2 \tan 10^\circ$

xi)  $\frac{\cos 27^\circ + \sin 27^\circ}{\cos 27^\circ - \sin 27^\circ} = \tan 72^\circ$

xii)  $\tan 10^\circ + \tan 35^\circ + \tan 10^\circ \cdot \tan 35^\circ = 1$

xiii)  $\frac{\cot A \cot 4A + 1}{\cot A \cot 4A - 1} = \frac{\cos 3A}{\cos 5A}$

xiv)  $\frac{\cos 15^\circ - \sin 15^\circ}{\cos 15^\circ + \sin 15^\circ} = \frac{1}{\sqrt{3}}$

3) If  $\sin A = \frac{-5}{13}$ ,  $\pi < A < \frac{3\pi}{2}$  and

$\cos B = \frac{3}{5}$ ,  $\frac{3\pi}{2} < B < 2\pi$

find i)  $\sin(A+B)$  ii)  $\cos(A-B)$   
iii)  $\tan(A+B)$

4) If  $\tan A = \frac{5}{6}$ ,  $\tan B = \frac{1}{11}$ , prove that  $A+B = \frac{\pi}{4}$



**Let's Learn**

**3.2 Trigonometric functions of allied angles.**

**Allied angles :** If the sum or difference of the measures of two angles is either '0' or an integral multiple of  $\frac{\pi}{2}$  then these angles are said to be allied angles.

If  $\theta$  is the measure of an angle the

$-\theta, \frac{\pi}{2} \pm \theta, \pi \pm \theta, \frac{3\pi}{2} \pm \theta, 2\pi - \theta$  are its allied angles.

We have already proved the following results :

1)  $\sin(\frac{\pi}{2} - \theta) = \cos \theta$ ,  $\cos(\frac{\pi}{2} - \theta) = \sin \theta$ ,  
 $\tan(\frac{\pi}{2} - \theta) = \cot \theta$

2)  $\sin(\frac{\pi}{2} + \theta) = \cos \theta$ ,  $\cos(\frac{\pi}{2} + \theta) = -\sin \theta$ ,  
 $\tan(\frac{\pi}{2} + \theta) = -\cot \theta$

Similarly we can also prove the following results :

1)  $\sin(\pi - \theta) = \sin \theta$ ,  $\cos(\pi - \theta) = -\cos \theta$ ,  
 $\tan(\pi - \theta) = -\tan \theta$

2)  $\sin(\pi + \theta) = -\sin \theta$ ,  $\cos(\pi + \theta) = -\cos \theta$ ,  
 $\tan(\pi + \theta) = \tan \theta$

3)  $\sin(\frac{3\pi}{2} - \theta) = -\cos \theta$ ,  $\cos(\frac{3\pi}{2} - \theta) = -\sin \theta$ ,  
 $\tan(\frac{3\pi}{2} - \theta) = \cot \theta$

4)  $\sin(\frac{3\pi}{2} + \theta) = -\cos \theta$ ,  $\cos(\frac{3\pi}{2} + \theta) = \sin \theta$ ,

$\tan(\frac{3\pi}{2} + \theta) = -\cot \theta$

5)  $\sin(2\pi - \theta) = -\sin \theta$ ,  $\cos(2\pi - \theta) = \cos \theta$ ,  
 $\tan(2\pi - \theta) = -\tan \theta$

Above results are tabulated in following table .

allied angles/ Trigonometric functions	$-\theta$	$\frac{\pi}{2} - \theta$	$\frac{\pi}{2} + \theta$	$\pi - \theta$	$\pi + \theta$	$2\pi - \theta$	$2\pi + \theta$
sin	$-\sin \theta$	$\cos \theta$	$\cos \theta$	$\sin \theta$	$-\sin \theta$	$-\sin \theta$	$\sin \theta$
cos	$\cos \theta$	$\sin \theta$	$-\sin \theta$	$-\cos \theta$	$-\cos \theta$	$\cos \theta$	$\cos \theta$
tan	$-\tan \theta$	$\cot \theta$	$-\cot \theta$	$-\tan \theta$	$\tan \theta$	$\tan \theta$	$\tan \theta$

**SOLVED EXAMPLES**

**Ex. 1)** Find the values of

i)  $(\sin 495^\circ)$  ii)  $\cos 930^\circ$  iii)  $\tan 840^\circ$

**Solution :**

i)  $\sin(495^\circ) = \sin 495^\circ$  ii)  $\cos 930^\circ$   
 $= \sin(360^\circ + 135^\circ) = \cos(2 \times 360^\circ + 210^\circ)$   
 $= \sin 135^\circ = \cos 210^\circ$

$= \sin(\frac{\pi}{2} + 45^\circ) = \cos(\pi + 30^\circ)$   
 $= \cos 45^\circ = \frac{1}{\sqrt{2}} = -\cos 30^\circ = -\frac{\sqrt{3}}{2}$

iii)  $\tan 840^\circ = \tan(2 \times 360^\circ + 120^\circ) = \tan 120^\circ = \tan(\frac{\pi}{2} + 30^\circ) = -\cot 30^\circ = -\sqrt{3}$

**Ex. 2)** Show that :

i)  $\cos 24^\circ + \cos 55^\circ + \cos 125^\circ + \cos 204^\circ + \cos 300^\circ = \frac{1}{2}$

**Solution :**

L.H.S. =  $\cos 24^\circ + \cos 55^\circ + \cos 125^\circ + \cos 204^\circ + \cos 300^\circ$

$$\begin{aligned}
 &= \cos 24^\circ + \cos 55^\circ + \cos (180^\circ - 55^\circ) + \\
 &\quad \cos (180^\circ + 24^\circ) + \cos (360^\circ - 60^\circ) \\
 &= \cos 24^\circ + \cos 55^\circ - \cos 55^\circ - \cos 24^\circ \\
 &\quad + \cos 60^\circ \\
 &= \cos 60^\circ = \frac{1}{2} = R.H.S.
 \end{aligned}$$

$$\begin{aligned}
 \text{ii) } \sec 840^\circ \cdot \cot (-945^\circ) + \sin 600^\circ \cdot \tan (-690^\circ) \\
 = \frac{3}{2}
 \end{aligned}$$

**Solution :**

$$\begin{aligned}
 \sec 840^\circ &= \sec (2 \times 360^\circ + 120^\circ) = \sec 120^\circ \\
 &= \sec (90^\circ + 30^\circ) = -\operatorname{cosec} 30^\circ \\
 &= -2
 \end{aligned}$$

$$\begin{aligned}
 \cot (-945^\circ) &= -\cot 945^\circ = -\cot (2 \times 360^\circ + 225^\circ) \\
 &= -\cot 225^\circ \\
 &= -\cot (180^\circ + 45^\circ) = -\cot 45^\circ = -1
 \end{aligned}$$

$$\begin{aligned}
 \sin 600^\circ &= \sin (360^\circ + 240^\circ) = \sin 240^\circ \\
 &= \sin (180^\circ + 60^\circ) \\
 &= -\sin 60^\circ = -\frac{\sqrt{3}}{2}
 \end{aligned}$$

$$\begin{aligned}
 \tan (-690^\circ) &= -\tan 690^\circ = -\tan (2 \times 360^\circ - 30^\circ) \\
 &= -(-\tan 30^\circ) \\
 &= \tan 30^\circ = \frac{1}{\sqrt{3}}
 \end{aligned}$$

L.H.S.

$$\begin{aligned}
 &= \sec 840^\circ \cdot \cot (-945^\circ) + \sin 600^\circ \cdot \tan (-690^\circ) \\
 &= -2 \times -1 + \left( -\frac{\sqrt{3}}{2} \times \frac{1}{\sqrt{3}} \right) \\
 &= 2 - \frac{1}{2} = \frac{4-1}{2} = \frac{3}{2} = R.H.S.
 \end{aligned}$$

$$\begin{aligned}
 \text{iii) } \frac{\operatorname{cosec} (90^\circ - \theta) \cdot \sin (180^\circ - \theta) \cot (360^\circ - \theta)}{\sec (180^\circ + \theta) \tan (90^\circ + \theta) \sin (-\theta)} = 1
 \end{aligned}$$

L.H.S.

$$\begin{aligned}
 &= \frac{\operatorname{cosec} (90^\circ - \theta) \cdot \sin (180^\circ - \theta) \cot (360^\circ - \theta)}{\sec (180^\circ + \theta) \tan (90^\circ + \theta) \sin (-\theta)} \\
 &= \frac{\sec \theta \sin \theta (-\cot \theta)}{(-\sec \theta)(-\cot \theta)(-\sin \theta)}
 \end{aligned}$$

$$= \frac{-\sec \theta \sin \theta \cot \theta}{-\sec \theta \cot \theta \sin \theta} = 1 = R.H.S.$$

$$\text{iv) } \frac{\cot \left( \frac{\pi}{2} + \theta \right) \sin (-\theta) \cot (\pi - \theta)}{\cos (2\pi - \theta) \sin (\pi + \theta) \tan (2\pi - \theta)} = -\operatorname{cosec} \theta$$

L.H.S.

$$= \frac{\cot \left( \frac{\pi}{2} + \theta \right) \sin (-\theta) \cot (\pi - \theta)}{\cos (2\pi - \theta) \sin (\pi + \theta) \tan (2\pi - \theta)}$$

$$= \frac{(-\tan \theta)(-\sin \theta)(-\cot \theta)}{\cos \theta (-\sin \theta)(-\tan \theta)}$$

$$= \frac{-\cot \theta}{+\cos \theta}$$

$$= -\frac{\cos \theta}{\sin \theta} \times \frac{1}{\cos \theta} = \frac{1}{\sin \theta} = -\operatorname{cosec} \theta = R.H.S.$$

**Ex. 3) Prove the following :**

$$\text{i) } \sin \frac{\pi}{15} + \sin \frac{4\pi}{15} - \sin \frac{14\pi}{15} - \sin \frac{11\pi}{15} = 0$$

**Solution :** L.H.S

$$= \sin \frac{\pi}{15} + \sin \frac{4\pi}{15} - \sin \frac{14\pi}{15} - \sin \frac{11\pi}{15}$$

$$= \sin \frac{\pi}{15} + \sin \frac{4\pi}{15} - \sin \left( \pi - \frac{\pi}{15} \right) - \sin \left( \pi - \frac{4\pi}{15} \right)$$

$$= \sin \frac{\pi}{15} + \sin \frac{4\pi}{15} - \sin \frac{\pi}{15} - \sin \frac{4\pi}{15}$$

$$= 0$$

$$= R.H.S.$$

$$\text{ii) } \sin^2\left(\frac{\pi}{4} - x\right) + \sin^2\left(\frac{\pi}{4} + x\right) = 1$$

**Solution :** consider  $\frac{\pi}{4} - x = y \therefore x = \frac{\pi}{4} - y$

$$\begin{aligned} \text{L.H.S.} &= \sin^2\left(\frac{\pi}{4} - x\right) + \sin^2\left(\frac{\pi}{4} + x\right) \\ &= \sin^2 y + \sin^2\left(\frac{\pi}{4} + \frac{\pi}{4} - y\right) \\ &= \sin^2 y + \cos^2 y \\ &= 1 = \text{R.H.S.} \end{aligned}$$

$$\text{iii) } \sin^2 \frac{\pi}{8} + \sin^2 \frac{3\pi}{8} + \sin^2 \frac{5\pi}{8} + \sin^2 \frac{7\pi}{8} = 2$$

**Solution :** L.H.S.

$$\begin{aligned} &= \sin^2 \frac{\pi}{8} + \sin^2 \frac{3\pi}{8} + \sin^2 \frac{5\pi}{8} + \sin^2 \frac{7\pi}{8} \\ &= \sin^2 \frac{\pi}{8} + \sin^2 \frac{3\pi}{8} \\ &\quad + \sin^2\left(\frac{4\pi + \pi}{8}\right) + \sin^2\left(\frac{4\pi + 3\pi}{8}\right) \\ &= \sin^2 \frac{\pi}{8} + \sin^2 \frac{3\pi}{8} + \sin^2\left(\frac{\pi}{2} + \frac{\pi}{8}\right) + \sin^2\left(\frac{\pi}{2} + \frac{3\pi}{8}\right) \\ &= \sin^2 \frac{\pi}{8} + \sin^2 \frac{3\pi}{8} + \cos^2 \frac{\pi}{8} + \cos^2 \frac{3\pi}{8} \\ &= 1 + 1 \\ &= 2 = \text{R.H.S.} \end{aligned}$$

iv)

$$\cos^2\left(\frac{\pi}{10}\right) + \cos^2\left(\frac{2\pi}{5}\right) + \cos^2\left(\frac{3\pi}{5}\right) + \cos^2\left(\frac{9\pi}{10}\right) = 2$$

**Solution :** L.H.S

$$\begin{aligned} &= \cos^2\left(\frac{\pi}{10}\right) + \cos^2\left(\frac{2\pi}{5}\right) + \cos^2\left(\frac{3\pi}{5}\right) + \cos^2\left(\frac{9\pi}{10}\right) \\ &= \cos^2\left(\frac{\pi}{10}\right) + \cos^2\left(\frac{\pi}{2} - \frac{\pi}{10}\right) + \cos^2\left(\frac{\pi}{2} + \frac{\pi}{10}\right) + \cos^2\left(\pi - \frac{\pi}{10}\right) \\ &= \cos^2\left(\frac{\pi}{10}\right) + \sin^2\left(\frac{\pi}{10}\right) + \cos^2\left(\frac{\pi}{10}\right) + \sin^2\left(\frac{\pi}{10}\right) \\ &= 1 + 1 \\ &= 2 = \text{R.H.S.} \end{aligned}$$

### EXERCISE 3.2

1) Find the value of :

- |                                      |                           |
|--------------------------------------|---------------------------|
| i) $\sin 690^\circ$                  | ii) $\sin (495^\circ)$    |
| iii) $\cos 315^\circ$                | iv) $\cos (600^\circ)$    |
| v) $\tan 225^\circ$                  | vi) $\tan (-690^\circ)$   |
| vii) $\sec 240^\circ$                | viii) $\sec (-855^\circ)$ |
| ix) $\operatorname{cosec} 780^\circ$ | x) $\cot (-1110^\circ)$   |

2) Prove the following:

- $\frac{\cos(\pi + x)\cos(-x)}{\sin(\pi - x)\cos\left(\frac{\pi}{2} + x\right)} = \cot^2 x$
- $\cos\left(\frac{3\pi}{2} + x\right)\cos(2\pi + x)[\cot\left(\frac{3\pi}{2} - x\right) + \cot(2\pi + x)] = 1$
- $\sec 840^\circ \cdot \cot(-945^\circ) + \sin 600^\circ \tan(-690^\circ) = \frac{3}{2}$
- $\frac{\operatorname{cosec}(90^\circ - x)\sin(180^\circ - x)\cot(360^\circ - x)}{\sec(180^\circ + x)\tan(90^\circ + x)\sin(-x)} = 1$
- $\frac{\sin^3(\pi + x)\sec^2(\pi - x)\tan(2\pi - x)}{\cos^2\left(\frac{\pi}{2} + x\right)\sin(\pi - x)\operatorname{cosec}^2 - x} = \tan^3 x$
- $\cos\theta + \sin(270^\circ + \theta) - \sin(270^\circ - \theta) + \cos(180^\circ + \theta) = 0$



### Let's Learn

### 3.3 Trigonometric functions of multiple angles.

Angles of the form  $2\theta, 3\theta, 4\theta$  etc. are integral multiple of  $\theta$  these angles are called multiple angles and angles of the form  $\frac{\theta}{2}, \frac{3\theta}{2}$  etc. are called submultiple angles of  $\theta$ .

### 3.3.1 Trigonometric functions of double angles

(2θ)

**Theorem :** For any angle θ,

$$1) \sin 2\theta = 2\sin\theta \cos\theta = \frac{2\tan\theta}{1+\tan^2\theta}$$

$$2) \cos 2\theta = \cos^2\theta - \sin^2\theta = 2\cos^2\theta - 1$$

$$= 1 - 2\sin^2\theta = \frac{1-\tan^2\theta}{1+\tan^2\theta}$$

$$3) \tan 2\theta = \frac{2\tan\theta}{1-\tan^2\theta}$$

**Proof:** 1)  $\sin 2\theta = \sin(\theta + \theta)$

$$= \sin\theta \cos\theta + \cos\theta \sin\theta$$

$$= 2\sin\theta \cos\theta \dots\dots(1)$$

$$= \frac{2\sin\theta \cos\theta}{1}$$

$$= \frac{2\sin\theta \cos\theta}{\sin^2\theta + \cos^2\theta}$$

$$= \frac{2\sin\theta \cos\theta / \cos^2\theta}{(\sin^2\theta + \cos^2\theta) / \cos^2\theta}$$

$$= \frac{2\sin\theta \cos\theta}{\frac{\sin^2\theta}{\cos^2\theta} + 1}$$

$$= \frac{2\tan\theta}{1+\tan^2\theta} \dots\dots(2)$$

From (1) and (2)

$$\sin 2\theta = 2\sin\theta \cos\theta = \frac{2\tan\theta}{1+\tan^2\theta}$$

$$2) \cos 2\theta = \cos(\theta + \theta)$$

$$= \cos\theta \cos\theta - \sin\theta \sin\theta$$

$$= \cos^2\theta - \sin^2\theta \dots\dots(1)$$

$$= \cos^2\theta - (1 - \cos^2\theta)$$

$$= \cos^2\theta - 1 + \cos^2\theta$$

$$= 2\cos^2\theta - 1 \dots\dots(2)$$

$$= 2(1 - \sin^2\theta) - 1$$

$$= 2 - 2\sin^2\theta - 1$$

$$= 1 - 2\sin^2\theta \dots\dots(3)$$

$$= \cos^2\theta - \sin^2\theta$$

$$= \frac{\cos^2\theta - \sin^2\theta}{1}$$

$$= \frac{\cos^2\theta - \sin^2\theta}{\cos^2\theta + \sin^2\theta}$$

$$= \frac{\cos^2\theta - \sin^2\theta}{\frac{\cos^2\theta}{\cos^2\theta}}$$

$$= \frac{1 - \frac{\sin^2\theta}{\cos^2\theta}}{1 + \frac{\sin^2\theta}{\cos^2\theta}}$$

$$= \frac{1 - \tan^2\theta}{1 + \tan^2\theta} \dots\dots(4)$$

From (1), (2), (3) and (4) we get

$$\cos 2\theta = \cos^2\theta - \sin^2\theta = 2\cos^2\theta - 1$$

$$= 1 - 2\sin^2\theta$$

$$= \frac{1 - \tan^2\theta}{1 + \tan^2\theta}$$

$$3) \tan 2\theta = \frac{2\tan\theta}{1+\tan^2\theta}$$

Note that the substitution  $2\theta = t$  transforms  $\sin 2\theta = 2\sin\theta \cdot \cos\theta$  into  $\sin t = 2\sin \frac{t}{2} \cdot \cos \frac{t}{2}$ .

Similarly,

$$\cos 2\theta = \cos^2\theta - \sin^2\theta \text{ and } \cos t = \cos^2 \frac{t}{2} - \sin^2 \frac{t}{2}$$

$$\tan 2\theta = \frac{2\tan\theta}{1+\tan^2\theta} \text{ and } \tan t = \frac{2\tan \frac{t}{2}}{1-\tan^2 \frac{t}{2}}$$

$$\begin{aligned} \text{Also if } \tan \frac{\theta}{2} = t \text{ then } \sin \theta &= \frac{2t}{1-t^2} &= \frac{3 \tan \theta - \tan^3 \theta}{1-3 \tan^2 \theta} \\ \text{and } \cos \theta &= \frac{1-t^2}{1+t^2} \text{ and } \tan \theta = \frac{2t}{1-t^2} &\therefore \tan 3\theta = \frac{3 \tan \theta - \tan^3 \theta}{1-3 \tan^2 \theta} \end{aligned}$$

### 3.3.2 Trigonometric functions of triple angle (3θ)

**Theorem :** 1) For any angle θ

$$1) \sin 3\theta = 3 \sin \theta - 4 \sin^3 \theta$$

$$2) \cos 3\theta = 4 \cos^3 \theta - 3 \cos \theta$$

$$3) \tan 3\theta = \frac{3 \tan \theta - \tan^3 \theta}{1 - 3 \tan^2 \theta}$$

**Proof:**

$$\begin{aligned} 1) \sin 3\theta &= \sin (2\theta + \theta) \\ &= \sin 2\theta \cos \theta + \cos 2\theta \sin \theta \\ &= 2 \sin \theta \cos \theta \cdot \cos \theta + (1 - 2 \sin^2 \theta) \sin \theta \\ &= 2 \sin \theta \cos^2 \theta + \sin \theta - 2 \sin^3 \theta \\ &= 2 \sin \theta (1 - \sin^2 \theta) + \sin \theta - 2 \sin^3 \theta \\ &= 2 \sin \theta - 2 \sin^3 \theta + \sin \theta - 2 \sin^3 \theta \\ &= 3 \sin \theta - 4 \sin^3 \theta \\ \therefore \sin 3\theta &= 3 \sin \theta - 4 \sin^3 \theta \end{aligned}$$

**(Activity)**

$$2) \cos 3\theta = \cos (2\theta + \theta)$$

$$3) \tan 3\theta = \tan (2\theta + \theta)$$

$$\begin{aligned} &= \frac{\tan 2\theta + \tan \theta}{1 - \tan 2\theta \tan \theta} \\ &= \frac{\left( \frac{2 \tan \theta}{1 - \tan^2 \theta} \right) + \tan \theta}{\left( 1 - \frac{2 \tan \theta}{1 - \tan^2 \theta} \right) \tan \theta} \\ &= \frac{2 \tan \theta + \tan \theta (1 - \tan^2 \theta)}{1 - \tan^2 \theta} \\ &= \frac{(1 - \tan^2 \theta) - 2 \tan^2 \theta}{1 - \tan^2 \theta} \\ &= \frac{2 \tan \theta + \tan \theta - \tan^3 \theta}{1 - 3 \tan^2 \theta} \end{aligned}$$

### SOLVED EXAMPLES

**Ex. 1)** Prove that  $1 + \tan \theta \tan \frac{\theta}{2} = \sec \theta$

**Solution :**

$$\begin{aligned} \text{L.H.S} &= 1 + \tan \theta \tan \left( \frac{\theta}{2} \right) \\ &= 1 + \frac{\sin \theta}{\cos \theta} \cdot \frac{\sin \frac{\theta}{2}}{\cos \frac{\theta}{2}} \\ &= 1 + \frac{2 \sin \frac{\theta}{2} \cos \frac{\theta}{2} \cdot \sin \frac{\theta}{2}}{\cos \theta \cos \frac{\theta}{2}} \\ &= 1 + \frac{2 \sin^2 \frac{\theta}{2}}{\cos \theta} \\ &= 1 + \frac{1 - \cos \theta}{\cos \theta} \\ &= \frac{\cos \theta + 1 - \cos \theta}{\cos \theta} \\ &= \frac{1}{\cos \theta} = \sec \theta = \text{R.H.S} \end{aligned}$$

**Ex. 2)** Prove that  $\tan 20^\circ \tan 40^\circ \tan 60^\circ \tan 80^\circ = 3$

**Solution :**

$$\begin{aligned} \text{L.H.S.} &= \tan 20^\circ \tan 40^\circ \tan 60^\circ \tan 80^\circ \\ &= \tan 20^\circ \tan 40^\circ \cdot \sqrt{3} \tan 80^\circ \\ &= \sqrt{3} \tan 20^\circ \tan (60^\circ - 20^\circ) \tan (60^\circ + 20^\circ) \end{aligned}$$

$$\begin{aligned}
 &= \sqrt{3} \tan 20^\circ \cdot \frac{\tan 60^\circ - \tan 20^\circ}{1 + \tan 60^\circ \tan 20^\circ} \cdot \frac{\tan 60^\circ + \tan 20^\circ}{1 - \tan 60^\circ \tan 20^\circ} = \frac{-3\cos^3\theta + 3\cos\theta}{\cos\theta} + \frac{3\sin\theta - 3\sin^3\theta}{\sin\theta} \\
 &= \sqrt{3} \tan 20^\circ \cdot \frac{\sqrt{3} - \tan 20^\circ}{1 + \sqrt{3}\tan 20^\circ} \cdot \frac{\sqrt{3} + \tan 20^\circ}{1 - \sqrt{3}\tan 20^\circ} = \frac{3\cos\theta(1 - \cos^2\theta)}{\cos\theta} + \frac{3\sin\theta(1 - \sin^2\theta)}{\sin\theta} \\
 &= \sqrt{3} \tan 20^\circ \cdot \frac{3 - \tan^2 20^\circ}{1 - 3\tan^2 20^\circ} = 3 \sin^2\theta + 3 \cos^2\theta \\
 &= \sqrt{3} \frac{3\tan 20^\circ - \tan^3 20^\circ}{1 - 3\tan^2 20^\circ} = 3(\sin^2\theta + \cos^2\theta) \\
 &= \sqrt{3} \tan [3(20)]^\circ = 3(1) = 3 = \text{R.H.S.} \\
 &= \sqrt{3} \tan 60^\circ \\
 &= \sqrt{3} \cdot \sqrt{3} = 3 = \text{R. H. S}
 \end{aligned}$$

**Ex. 3)** Prove that  $2\operatorname{cosec}2x + \operatorname{cosec}x = \operatorname{sec}x \cdot \cot(x/2)$

**Solution :** L.H.S. =  $2\operatorname{cosec}2x + \operatorname{cosec}x$

$$\begin{aligned}
 &= \frac{2}{\sin 2x} + \frac{1}{\sin x} \\
 &= \frac{2}{2\sin x \cos x} + \frac{1}{\sin x} \\
 &= \frac{1 + \cos x}{\sin x \cos x} \\
 &= \frac{2\cos^2(x/2)}{2\sin(x/2)\cos(x/2)\cos x} \\
 &= \frac{\cos(x/2)}{\sin(x/2)} \cdot \frac{1}{\cos x} \\
 &= \cot(x/2) \cdot \operatorname{sec}x = \text{R. H. S.}
 \end{aligned}$$

**Ex. 4)** Prove that  $\frac{\cos^3\theta - \cos 3\theta}{\cos\theta} + \frac{\sin^3\theta + \sin 3\theta}{\sin\theta} = 3$

**Solution :** L.H.S.

$$\begin{aligned}
 &= \frac{\cos^3\theta - \cos 3\theta}{\cos\theta} + \frac{\sin^3\theta + \sin 3\theta}{\sin\theta} \\
 &= \frac{\cos^3\theta - [4\cos^3\theta - 3\cos\theta]}{\cos\theta} + \frac{\sin^3\theta + [3\sin\theta - 4\sin^3\theta]}{\sin\theta}
 \end{aligned}$$

**Ex. 5)** Prove that  $\frac{\tan 5A + \tan 3A}{\tan 5A - \tan 3A} = 4\cos^2 A \cdot \cos 4A$

**Soln. :** L.H.S. =  $\frac{\tan 5A + \tan 3A}{\tan 5A - \tan 3A}$

$$\begin{aligned}
 &= \frac{\frac{\sin 5A}{\cos 5A} + \frac{\sin 3A}{\cos 3A}}{\frac{\sin 5A}{\cos 5A} - \frac{\sin 3A}{\cos 3A}} \\
 &= \frac{\frac{\sin 5A \cos 3A + \cos 5A \sin 3A}{\cos 5A \cos 3A}}{\frac{\sin 5A \cos 3A - \cos 5A \sin 3A}{\cos 5A \cos 3A}} \\
 &= \frac{\sin 5A \cos 3A + \cos 5A \sin 3A}{\sin 5A \cos 3A - \cos 5A \sin 3A} \\
 &= \frac{\sin 8A}{\sin 2A} = \frac{2\sin 4A \cos 4A}{\sin 2A} \\
 &= \frac{2 \cdot 2\sin 2A \cos 2A \cos 4A}{\sin 2A} \\
 &= 4 \cos^2 A \cos 4A = \text{R. H. S.}
 \end{aligned}$$

**Ex. 6)** Show that  $(\cos\theta + i\sin\theta)^3 = \cos 3\theta + i\sin 3\theta$ , where  $i^2 = -1$ .

**Solution :** L.H.S. =  $[\cos\theta + i\sin\theta]^3$

$$\begin{aligned}
 &= \cos^3\theta + 3i\cos^2\theta\sin\theta + 3i^2\cos\theta\sin^2\theta + i^3\sin^3\theta \\
 &= \cos^3\theta + 3i(1 - \sin^2\theta)\sin\theta - 3\cos\theta\sin^2\theta - i\sin^3\theta \\
 &= \cos^3\theta + 3i\sin\theta - 3i\sin^3\theta - 3\cos\theta(1 - \cos^2\theta) - i\sin^3\theta \\
 &= \cos^3\theta + 3i\sin\theta - 3i\sin^3\theta - 3\cos\theta + 3\cos^3\theta - i\sin^3\theta
 \end{aligned}$$

$$\begin{aligned}
 &= [4 \cos^3 \theta - 3 \cos \theta] + i [3 \sin \theta - 4 \sin^3 \theta] \\
 &= \cos 3\theta + i \sin 3\theta \\
 &= \text{R.H.S.}
 \end{aligned}$$

$$\begin{aligned}
 &= \tan \left( \frac{\pi}{4} + A \right) \\
 &= \text{R.H.S.}
 \end{aligned}$$

**Ex. 7)** Show that  $4 \sin \theta \cos^3 \theta - 4 \cos \theta \sin^3 \theta = \sin 4\theta$

**Solution:**

$$\begin{aligned}
 \text{L.H.S.} &= 4 \sin \theta \cos^3 \theta - 4 \cos \theta \sin^3 \theta \\
 &= 4 \sin \theta \cos \theta [\cos^2 - \sin^2 \theta] \\
 &= 2 \cdot (2 \sin \theta \cos \theta) (\cos^2 \theta - \sin^2 \theta) \\
 &= 2 \cdot \sin 2\theta \cdot \cos 2\theta \\
 &= \sin 4\theta \\
 &= \text{R.H.S.}
 \end{aligned}$$

**Ex. 8)** Show that  $\sqrt{\frac{1 + \sin 2A}{1 - \sin 2A}} = \tan \left( \frac{\pi}{4} + A \right)$

**Solution :**

$$\begin{aligned}
 \text{L.H.S.} &= \sqrt{\frac{1 + \sin 2A}{1 - \sin 2A}} \\
 &= \sqrt{\frac{\sin^2 A + \cos^2 A + 2 \sin A \cos A}{\sin^2 A + \cos^2 A - 2 \sin A \cos A}} \\
 &= \sqrt{\frac{(\sin A + \cos A)^2}{(\cos A - \sin A)^2}} \\
 &= \frac{\sin A + \cos A}{\cos A - \sin A} \\
 &= \frac{\cos A + \sin A}{\cos A - \sin A} \\
 &= \frac{1 + \frac{\sin A}{\cos A}}{1 - \frac{\sin A}{\cos A}} \\
 &= \frac{1 + \tan A}{1 - \tan A} \\
 &= \frac{\tan \frac{\pi}{4} + \tan A}{1 - \tan \frac{\pi}{4} \tan A} \quad \left[ \because 1 = \tan \frac{\pi}{4} \right]
 \end{aligned}$$

**Ex. 9)** Find  $\sin \frac{x}{2}, \cos \frac{x}{2}, \tan \frac{x}{2}$

if  $\tan x = \frac{4}{3}, x$  lies in II quadrant.

**Solution :** we know that  $1 + \tan^2 \theta = \sec^2 \theta$

$$\sec^2 x = 1 + \left( -\frac{4}{3} \right)^2 = 1 + \frac{16}{9} = \frac{9+16}{9} = \frac{25}{9}$$

$$\sec x = \pm \frac{5}{3}$$

But  $x$  lies in II quadrant.

$\therefore \sec x$  is negative.

$$\therefore \sec x = -\frac{5}{3} \quad \therefore \cos x = -\frac{3}{5}$$

$$\sin x = \sqrt{1 - \cos^2 x} = \sqrt{1 - \left( -\frac{3}{5} \right)^2} = \sqrt{1 - \frac{9}{25}} = \pm \frac{4}{5}$$

$$\therefore \sin x = \frac{4}{5} \quad \left[ \because x \text{ lies in II quadrant} \right]$$

$$\text{But } \sin \frac{x}{2} = \sqrt{\frac{1 - \cos x}{2}} = \sqrt{\frac{1 - \left( -\frac{3}{5} \right)}{2}}$$

$$= \sqrt{\frac{5+3}{2 \times 5}} = \sqrt{\frac{4}{5}} = \frac{2}{\sqrt{5}}$$

$$\cos \frac{x}{2} = \sqrt{\frac{1 + \cos x}{2}} = \sqrt{\frac{1 - \left( -\frac{3}{5} \right)}{2}}$$

$$= \sqrt{\frac{5-3}{2 \times 5}} = \sqrt{\frac{1}{5}} = \frac{1}{\sqrt{5}}$$

$$\tan \frac{x}{2} = \frac{\sin \frac{x}{2}}{\cos \frac{x}{2}} = \sqrt{\frac{4}{5}} = \sqrt{\frac{4}{5} \times \frac{5}{1}} = \sqrt{4} = 2$$

$$\therefore \sin \frac{x}{2} = \frac{2}{\sqrt{5}}, \cos \frac{x}{2} = \frac{1}{\sqrt{5}}, \tan \frac{x}{2} = 2$$

**Ex. 10)** Find the value of  $\tan \frac{\pi}{8}$

**Solution :** let  $x = \frac{\pi}{8} \therefore 2x = \frac{\pi}{4}$

$$\text{we have } \tan 2x = \frac{2 \tan x}{1 - \tan^2 x}$$

$$\therefore \tan \frac{\pi}{4} = \frac{2 \tan \frac{\pi}{8}}{1 - \tan^2 \frac{\pi}{8}}$$

$$\text{let } y = \tan \frac{\pi}{8} \quad \therefore 1 = \frac{2y}{1 - y^2}$$

$$\therefore 1 - y^2 = 2y$$

$$\therefore y^2 + 2y - 1 = 0$$

$$\therefore y = \frac{-2 \pm 2\sqrt{2}}{2} = -1 \pm \sqrt{2}$$

Since  $\frac{\pi}{8}$  lies in I quadrant  $y = \tan \frac{\pi}{8}$  positive

$$\therefore \tan \frac{\pi}{8} = \sqrt{2} - 1$$

**Ex. 11)** Prove that

$$\cos^2 x + \cos^2 \left( x + \frac{\pi}{3} \right) + \cos^2 \left( \pi - \frac{2\pi}{3} \right) = \frac{3}{2}$$

**Solution :** L.H.S.

$$= \cos^2 x + \cos^2 \left( x + \frac{\pi}{3} \right) + \cos^2 \left( \pi - \frac{2\pi}{3} \right)$$

$$= \frac{1 + \cos 2x}{2} + \frac{1 + \cos 2 \left( x + \frac{\pi}{3} \right)}{2} +$$

$$\frac{1 + \cos 2 \left( x - \frac{2\pi}{3} \right)}{2}$$

$$= \frac{1}{2} [3 + \cos 2x + \cos \left( 2x + \frac{2\pi}{3} \right)$$

$$+ \cos \left( 2x - \frac{2\pi}{3} \right)]$$

$$= \frac{1}{2} [3 + \cos 2x + 2 \cos 2x \cos \frac{2\pi}{3}]$$

$$= \frac{1}{2} [3 + \cos 2x + 2 \cos 2x \cos \left( \pi - \frac{2\pi}{3} \right)]$$

$$= \frac{1}{2} [3 + \cos 2x - 2 \cos 2x \cos \frac{\pi}{3}]$$

$$= \frac{1}{2} [3 + \cos 2x - \cos 2x]$$

$$= \frac{3}{2} = \text{R. H. S.}$$

**Ex. 12)** Find  $\sin \frac{\pi}{10}$

**Solution :**  $\frac{\pi^c}{10} = 18^\circ$

Let,  $\theta = 18^\circ$ ,  $2\theta = 36^\circ$ ,  $3\theta = 54^\circ$

We have  $2\theta + 3\theta = 90^\circ$

$$2\theta = 90^\circ - 3\theta$$

$$\therefore \sin 2\theta = \sin (90^\circ - 3\theta)$$

$$2 \sin \theta \cdot \cos \theta = \cos 3\theta$$

$$\therefore 2 \sin \theta \cdot \cos \theta = 4 \cdot \cos^3 \theta - 3 \cos \theta$$

$$2 \sin \theta = 4 \cdot \cos^2 \theta - 3$$

$$2 \sin \theta = 4 (1 - \sin^2 \theta) - 3$$

$$2 \sin \theta = 4 - 4 \sin^2 \theta - 3$$

$$4 \sin^2 \theta + 2 \sin \theta - 1 = 0$$

$$\therefore \sin \theta = \frac{-2 \pm \sqrt{4 + (4)(4)(1)}}{2(4)}$$

$$= \frac{-2 \pm 2\sqrt{5}}{2(4)}$$

$$\therefore \sin \theta = \frac{-1 \pm \sqrt{5}}{4}$$

$$\therefore \sin \theta = \frac{-1 + \sqrt{5}}{4}$$

[ $\because \theta$  is an acute angle]

$$\therefore \sin 18^\circ = \frac{-1 + \sqrt{5}}{4}$$

$$\therefore \sin \frac{\pi}{10} = \frac{-1 + \sqrt{5}}{4}$$

**EXERCISE 3.3**

- 1) Find values of : i)  $\sin \frac{\pi}{8}$  ii)  $\cos \frac{\pi}{8}$
- 2) Find  $\sin 2x, \cos 2x, \tan 2x$  if  $\sec x = \frac{-13}{5}$ ,  $\frac{\pi}{2} < x < \pi$
- 3) Prove the following:
  - i)  $\frac{1 - \cos 2\theta}{1 + \cos 2\theta} = \tan^2 \theta$
  - ii)  $(\sin 3x + \sin x)\sin x + (\cos 3x - \cos x)\cos x = 0$
  - iii)  $(\cos x - \cos y)^2 + (\sin x - \sin y)^2 = 4\cos^2 \frac{(x+y)}{2}$
  - iv)  $(\cos x - \cos y)^2 + (\sin x - \sin y)^2 = 4\sin^2 \frac{(x-y)}{2}$
  - v)  $\tan x + \cot x = 2 \operatorname{cosec} 2x$
  - vi)  $\frac{\cos x + \sin x}{\cos x - \sin x} - \frac{\cos x - \sin x}{\cos x + \sin x} = 2 \tan 2x$
  - vii)  $\sqrt{2 + \sqrt{2 + \sqrt{2 + \cos 8x}}} = 2 \cos x$
  - viii)  $16 \sin \theta \cos \theta \cos 2\theta \cos 4\theta \cos 8\theta = \sin 16\theta$
  - ix)  $\frac{\sin 3x}{\cos x} + \frac{\cos 3x}{\sin x} = 2 \cot 2x$
  - x)  $\frac{\cos x}{1 + \sin x} = \frac{\cot\left(\frac{x}{2}\right) - 1}{\cot\left(\frac{x}{2}\right) + 1}$
  - xi)  $\frac{\tan\left(\frac{\theta}{2}\right) + \cot\left(\frac{\theta}{2}\right)}{\cot\left(\frac{\theta}{2}\right) - \tan\left(\frac{\theta}{2}\right)} = \sec \theta$
  - xii)  $\frac{1}{\tan 3A - \tan A} - \frac{1}{\cot 3A - \cot A} = \cot 2A$
  - xiii)  $\cos 7^\circ \cos 14^\circ \cos 28^\circ \cos 56^\circ = \frac{\sin 68^\circ}{16 \cos 83^\circ}$
  - xiv)  $\frac{\sin^2(-160^\circ)}{\sin^2 70^\circ} + \frac{\sin(180^\circ - \theta)}{\sin \theta} = \sec^2 20^\circ$

- xv)  $\frac{2\cos 4x + 1}{2\cos x + 1} = (2 \cos x - 1)(2 \cos 2x - 1)$
- xvi)  $\cos^2 x + \cos^2(x + 120^\circ) + \cos^2(x - 120^\circ) = \frac{3}{2}$
- xvii)  $2\operatorname{cosec} 2x + \operatorname{cosec} x = \sec x \cot\left(\frac{x}{2}\right)$
- xviii)  $4\cos x \cos\left(x + \frac{\pi}{3}\right) + \cos^2\left(\pi - \frac{2\pi}{3}\right) = \cos 3x$
- xix)  $\sin x \tan\left(\frac{x}{2}\right) + 2\cos x = \frac{2}{1 + \tan^2\left(\frac{x}{2}\right)}$



**Let's Learn**

**3.4 Factorization formulae:**

Formulae for expressing sums and differences of trigonometric functions as products of sine and cosine functions are called factorization formulae. Formulae to express products in terms of sums and differences are called defactorization formulae.

**3.4.1 Formulae for conversion of sum or difference into product.**

**Theorem:** 9) For any angles C and D,

- 1)  $\sin C + \sin D = 2 \sin\left(\frac{C+D}{2}\right) \cos\left(\frac{C-D}{2}\right)$
- 2)  $\sin C - \sin D = 2 \cos\left(\frac{C+D}{2}\right) \sin\left(\frac{C-D}{2}\right)$
- 3)  $\cos C + \cos D = 2 \cos\left(\frac{C+D}{2}\right) \cos\left(\frac{C-D}{2}\right)$
- 4)  $\cos C - \cos D = -2 \sin\left(\frac{C+D}{2}\right) \sin\left(\frac{C-D}{2}\right)$   
 $= 2 \sin\left(\frac{C+D}{2}\right) \sin\left(\frac{D-C}{2}\right)$

**Proof:** We know that

$$\text{Let, } A = \frac{C+D}{2} \quad \text{and } B = \frac{C-D}{2}$$

$$\therefore A+B = C \quad \text{and } A-B = D$$

using these values in equations

$$\sin(A + B) + \sin(A - B) = 2 \sin A \cos B$$

$$\sin(A - B) + \sin(A + B) = 2 \cos A \sin B$$

we get

$$\sin C + \sin D = 2 \sin \left( \frac{C+D}{2} \right) \cos \left( \frac{C-D}{2} \right)$$

$$\sin C - \sin D = 2 \cos \left( \frac{C+D}{2} \right) \sin \left( \frac{C-D}{2} \right)$$

Similarly

the equations,

$$\cos(A + B) = \cos A \cos B - \sin A \sin B \dots\dots (3)$$

$$\cos(A - B) = \cos A \cos B + \sin A \sin B \dots\dots (4)$$

gives,

$$\cos C + \cos D = 2 \cos \left( \frac{C+D}{2} \right) \cos \left( \frac{C-D}{2} \right)$$

$$\therefore \cos C - \cos D = -2 \sin \left( \frac{C+D}{2} \right) \sin \left( \frac{C-D}{2} \right)$$

$$\therefore \sin(-\theta) = \sin \theta$$

$$\begin{aligned} \therefore -\sin \left( \frac{C-D}{2} \right) &= \sin \left( -\left( \frac{C-D}{2} \right) \right) \\ &= \sin \left( \frac{D-C}{2} \right) \end{aligned}$$

$$\therefore \cos C - \cos D = 2 \sin \left( \frac{C+D}{2} \right) \sin \left( \frac{D-C}{2} \right)$$

### 3.4.2 Formulae for conversion of product in to sum or difference :

For any angles A and B

1)  $2 \sin A \cos B = \sin(A + B) + \sin(A - B)$

2)  $2 \cos A \sin B = \sin(A + B) - \sin(A - B)$

3)  $2 \cos A \cos B = \cos(A + B) + \cos(A - B)$

4)  $2 \sin A \sin B = \cos(A - B) - \cos(A + B)$

### SOLVED EXAMPLES

**Ex. 1)** Prove the following :

i)  $\sin 40^\circ - \cos 70^\circ = \sqrt{3} \cos 80^\circ$

ii)  $\cos 40^\circ + \cos 50^\circ + \cos 70^\circ + \cos 80^\circ = \cos 20^\circ + \cos 10^\circ$

**Solution :**

$$\begin{aligned} \text{i) LHS} &= \sin 40^\circ - \cos 70^\circ \\ &= \sin(90^\circ - 50^\circ) - \cos 70^\circ \\ &= \cos 50^\circ - \cos 70^\circ \\ &= -2 \sin 60^\circ \sin(-10^\circ) \\ &= 2 \sin 60^\circ \sin 10^\circ \\ &= 2 \times \frac{\sqrt{3}}{2} \cos 80^\circ = \sqrt{3} \cos 80^\circ \\ &= \text{R.H.S} \end{aligned}$$

L.H.S.

$$\begin{aligned} &= \cos 40^\circ + \cos 50^\circ + \cos 70^\circ + \cos 80^\circ \\ &= (\cos 80^\circ + \cos 40^\circ) + (\cos 70^\circ + \cos 50^\circ) \\ &= 2 \cos \left( \frac{80+40}{2} \right) \cos \left( \frac{80-40}{2} \right) + 2 \cos \left( \frac{70+50}{2} \right) \cos \left( \frac{70-50}{2} \right) \\ &= 2 \cos 60^\circ \cos 20^\circ + 2 \cos 60^\circ \cos 10^\circ \\ &= 2 \cos 60^\circ (\cos 20^\circ + \cos 10^\circ) \\ &= 2 \times \frac{1}{2} (\cos 20^\circ + \cos 10^\circ) \\ &= \cos 20^\circ + \cos 10^\circ = \text{R. H. S.} \end{aligned}$$

**Ex. 2)** Express the following as sum or difference of two trigonometric function:

i)  $2 \sin 4\theta \cos 2\theta$

$$\begin{aligned} \text{Solution :} &= 2 \sin 4\theta \cos 2\theta \\ &= \sin(4\theta + 2\theta) + \sin(4\theta - 2\theta) \\ &= \sin 6\theta + \sin 2\theta \end{aligned}$$

$$\begin{aligned}
 \text{ii) } & 4 \sin \left( \frac{A+B}{2} \right) \sin \left( \frac{A-B}{2} \right) \\
 &= 2 \times \left[ \cos \left( \frac{A+B}{2} - \frac{A-B}{2} \right) - \cos \left( \frac{A+B}{2} + \frac{A-B}{2} \right) \right] \\
 &= 2[\cos B - \cos A] \\
 &= 2\cos B - 2\cos A
 \end{aligned}$$

**Ex. 3)** Show that

$$\text{i) } \frac{\sin 8x + \sin 2x}{\cos 2x - \cos 8x} = \cos 3x$$

**Solution :** L.H.S

$$\begin{aligned}
 &= \frac{\sin 8x + \sin 2x}{\cos 2x - \cos 8x} \\
 &= \frac{2 \sin \left( \frac{8x+2x}{2} \right) \cos \left( \frac{8x-2x}{2} \right)}{2 \sin \left( \frac{2x+8x}{2} \right) \sin \left( \frac{8x-2x}{2} \right)} \\
 &= \frac{2 \sin 5x \cos 3x}{2 \sin 5x \sin 3x} \\
 &= \cot 3x \\
 &= \text{R. H. S.}
 \end{aligned}$$

$$\text{ii) } \frac{\sin 2\alpha + \sin 2\beta}{\sin 2\alpha - \sin 2\beta} = \frac{\tan(\alpha + \beta)}{\tan(\alpha - \beta)}$$

**Solution :**

$$\begin{aligned}
 \text{L.H.S.} &= \frac{\sin 2\alpha + \sin 2\beta}{\sin 2\alpha - \sin 2\beta} \\
 &= \frac{2 \sin \left( \frac{2\alpha+2\beta}{2} \right) \cos \left( \frac{2\alpha-2\beta}{2} \right)}{2 \cos \left( \frac{2\alpha+2\beta}{2} \right) \sin \left( \frac{2\alpha-2\beta}{2} \right)} \\
 &= \frac{\sin(\alpha + \beta)}{\cos(\alpha + \beta)} \cdot \frac{\cos(\alpha - \beta)}{\sin(\alpha - \beta)} \\
 &= \tan(\alpha + \beta) \cdot \cot(\alpha - \beta) \\
 &= \frac{\tan(\alpha + \beta)}{\tan(\alpha - \beta)} \\
 &= \text{R. H.S.}
 \end{aligned}$$

**Ex. 4)** Prove that following.

$$\text{i) } \frac{\cos(7x-5y) + \cos(7y-5x)}{\sin(7x-5y) + \sin(7y-5x)} = \cot(x+y)$$

**Solution :** L.H.S.

$$\begin{aligned}
 &= \frac{\cos(7x-5y) + \cos(7y-5x)}{\sin(7x-5y) + \sin(7y-5x)} \\
 &= \frac{2 \cos \left( \frac{7x-5y+7y-5x}{2} \right) \cos \left( \frac{7x-5y-7y+5x}{2} \right)}{2 \sin \left( \frac{7x-5y+7y-5x}{2} \right) \cos \left( \frac{7x-5y-7y+5x}{2} \right)} \\
 &= \frac{\cos(x+y) \cos(6x-6y)}{\sin(x+y) \cos(6x-6y)} \\
 &= \frac{\cos(x+y)}{\sin(x+y)} = \cot(x+y) = \text{R. H. S.}
 \end{aligned}$$

$$\text{ii) } \sin 6\theta + \sin 4\theta - \sin 2\theta = 4 \cos \theta \sin 2\theta \cos 3\theta$$

**Solution :** L.H.S.

$$\begin{aligned}
 &= \sin 6\theta + \sin 4\theta - \sin 2\theta \\
 &= 2 \sin \left( \frac{6\theta+4\theta}{2} \right) \cos \left( \frac{6\theta-4\theta}{2} \right) - 2 \sin \theta \cos \theta \\
 &= 2 \sin 5\theta \cos \theta - 2 \sin \theta \cos \theta \\
 &= 2 \cos \theta [\sin 5\theta - \sin \theta] \\
 &= 2 \cos \theta \left[ 2 \cos \left( \frac{5\theta+\theta}{2} \right) \sin \left( \frac{5\theta-\theta}{2} \right) \right] \\
 &= 2 \cos \theta \cdot 2 \cos 3\theta \sin 2\theta \\
 &= 4 \cos \theta \sin 2\theta \cos 3\theta \\
 &= \text{R.H.S.}
 \end{aligned}$$

$$\text{iii) } \frac{\cos 3x \sin 9x - \sin x \cos 5x}{\cos x \cos 5x - \sin 3x \sin 9x} = \tan 8x$$

**Solution :** L.H.S.

$$\begin{aligned}
 &= \frac{\cos 3x \sin 9x - \sin x \cos 5x}{\cos x \cos 5x - \sin 3x \sin 9x} \\
 &= \frac{2 \cos 3x \sin 9x - 2 \sin x \cos 5x}{2 \cos x \cos 5x - 2 \sin 3x \sin 9x}
 \end{aligned}$$

$$\begin{aligned}
 &= \frac{[\sin(3x+9x) - \sin(3x-9x)] - [\sin(x+5x) + \sin(x-5x)]}{[\cos(x+5x) + \cos(x-5x)] - [\cos(9x-3x) - \cos(3x+9x)]} \\
 &= \frac{\sin 12x - \sin(-6x) - \sin 6x - \sin(-4x)}{\cos 6x + \cos(-4x) - \cos 6x + \cos 12x} \\
 &= \frac{\sin 12x + \sin 6x - \sin 6x + \sin 4x}{\cos 6x + \cos 4x - \cos 6x + \cos 12x} \\
 &= \frac{\sin 12x + \sin 4x}{\cos 12x + \cos 4x} \\
 &= \frac{2 \sin\left(\frac{12x+4x}{2}\right) \cos\left(\frac{12-4x}{2}\right)}{2 \cos\left(\frac{12x+4x}{2}\right) \cos\left(\frac{12x-4x}{2}\right)} \\
 &= \frac{\sin 8x}{\cos 8x} = \tan 8x = \text{R.H.S.}
 \end{aligned}$$

$$\text{iv) } \cos 20^\circ \cos 40^\circ \cos 60^\circ \cos 80^\circ = \frac{1}{16}$$

**Solution :** L.H.S.

$$\begin{aligned}
 &= \cos 20^\circ \cos 40^\circ \cos 60^\circ \cos 80^\circ \\
 &= \cos 20^\circ \cdot \cos 40^\circ \cdot \frac{1}{2} \cdot \cos 80^\circ \\
 &= \frac{1}{2} [\cos 20^\circ \cos 40^\circ \cos 80^\circ] \\
 &= \frac{1}{4} [\cos(20^\circ+40^\circ) + \cos(20^\circ-40^\circ)] \cos 80^\circ \\
 &= \frac{1}{4} [\cos 60^\circ + \cos(-20^\circ)] \cos 80^\circ \\
 &= \frac{1}{4} \left[ \frac{1}{2} \cos 80^\circ + \cos 20^\circ \cos 80^\circ \right] \\
 &= \frac{1}{4} \left[ \frac{1}{2} \cos 80^\circ + \cos 20^\circ \cos 80^\circ \right] \\
 &= \frac{1}{8} \cos 80^\circ + \frac{1}{4} \cdot \frac{1}{2} \cdot 2 \cos 20^\circ \cos 80^\circ \\
 &= \frac{1}{8} \cos 80^\circ + \frac{1}{8} [\cos(20+80) + \cos(20-80)] \\
 &= \frac{1}{8} \cos 80^\circ + \frac{1}{8} [\cos 100^\circ + \cos(-60)^\circ] \\
 &= \frac{1}{8} [\cos 80^\circ + [\cos 180^\circ - 80^\circ]] + \frac{1}{8} \times \frac{1}{2} \\
 &= \frac{1}{8} [\cos 80^\circ - \cos 80^\circ] + \frac{1}{16} = \frac{1}{16} \\
 &= \text{R.H.S.}
 \end{aligned}$$

### EXERCISE 3.4

1) Express the following as a sum or difference of two trigonometric function.

- $2 \sin 4x \cos 2x$
- $2 \sin \frac{2\pi}{3} \cos \frac{\pi}{2}$
- $2 \cos 4\theta \cos 2\theta$
- $2 \cos 35^\circ \cos 75^\circ$

2) Prove the following :

- $\frac{\sin 2x + \sin 2y}{\sin 2x - \sin 2y} = \frac{\tan(x+y)}{\tan(x-y)}$
- $\sin 6x + \sin 4x \sin 2x = 4 \cos x \sin 2x \cos 3x$
- $\frac{\sin x - \sin 3x + \sin 5x - \sin 7x}{\cos x - \cos 3x - \cos 5x + \cos 7x} = \cot 2x$
- $\sin 18^\circ \cos 39^\circ + \sin 6^\circ \cos 15^\circ = \sin 24^\circ \cos 33^\circ$
- $\cos 20^\circ \cos 40^\circ \cos 60^\circ \cos 80^\circ = \frac{1}{16}$
- $\sin 20^\circ \sin 40^\circ \sin 60^\circ \sin 80^\circ = \frac{3}{16}$



### Let's Learn

### 3.5 Trigonometric functions of angles of a triangle

Notation: In  $\Delta ABC$ ;  $m \angle BAC = A$ ,  
 $m \angle ABC = B$ ,  $m \angle ACB = C$   
 $\therefore A + B + C = \pi$

**Result 1)** In  $\Delta ABC$ ,  $A + B + C = \pi$   
 $\therefore A + B = \pi - C$   
 $\therefore \sin(A + B) = \sin(\pi - C)$   
 $\therefore \sin(A + B) = \sin C$

**Similarly:**

$$\begin{aligned}
 \sin(B + C) &= \sin A \quad \text{and} \\
 \sin(C + B) &= \sin A
 \end{aligned}$$

**Result 2)** In  $\Delta ABC$ ,  $A+B+C = \pi$

$$\begin{aligned} \therefore B + C &= \pi - A \\ \therefore \cos(B + C) &= \cos(\pi - A) \\ \therefore \cos(B + C) &= -\cos A \end{aligned}$$

**Similarly:**

$$\begin{aligned} \cos(A + B) &= -\cos C \quad \text{and} \\ \cos(C + A) &= -\cos B \end{aligned}$$

**Result 3)** for any  $\Delta ABC$

$$\text{i) } \sin\left(\frac{A+B}{2}\right) = \cos\frac{C}{2}$$

$$\sin\left(\frac{B+C}{2}\right) = \cos\frac{A}{2}$$

$$\sin\left(\frac{C+A}{2}\right) = \cos\frac{B}{2}$$

$$\text{ii) } \cos\left(\frac{A+B}{2}\right) = \sin\frac{C}{2}$$

$$\cos\left(\frac{B+C}{2}\right) = \sin\frac{A}{2}$$

$$\cos\left(\frac{C+A}{2}\right) = \sin\frac{B}{2}$$

**Proof.**

i) In  $\Delta ABC$ ,  $A+B+C = \pi \therefore A+B = \pi - C$

$$\therefore \left(\frac{A+B}{2}\right) = \frac{\pi - C}{2} = \frac{\pi}{2} - \frac{C}{2}$$

$$\sin\left(\frac{A+B}{2}\right) = \sin\left(\frac{\pi}{2} - \frac{C}{2}\right) = \cos\frac{C}{2}$$

$$\sin\left(\frac{A+B}{2}\right) = \cos\frac{C}{2}$$

**Verify.**

$$1) \sin\left(\frac{B+C}{2}\right) = \cos\frac{A}{2}$$

$$2) \cos\left(\frac{B+C}{2}\right) = \sin\frac{A}{2}$$

ii) In  $\Delta ABC$ ,  $A+B+C = \pi \therefore B + C = \pi - A$

$$\therefore \cos\left(\frac{A+C}{2}\right) = \cos\left(\frac{\pi}{2} - \frac{B}{2}\right) = \sin\frac{B}{2}$$

$$\therefore \cos\left(\frac{A+C}{2}\right) = \sin\frac{B}{2}$$

**Verify.**

$$1) \cos\left(\frac{A+B}{2}\right) = \sin\frac{C}{2}$$

$$2) \cos\left(\frac{B+C}{2}\right) = \sin\frac{A}{2}$$

### SOLVED EXAMPLES

**Ex. 1)** In  $\Delta ABC$  prove that

$$\text{i) } \sin 2A + \sin 2B - \sin 2C = 4 \cos A \cos B \sin C$$

**Solution :** L.H.S. =  $\sin 2A + \sin 2B - \sin 2C$

$$= 2 \sin\left(\frac{2A+2B}{2}\right) \cos\left(\frac{2A-2B}{2}\right) - \sin 2C$$

$$= 2 \sin(A+B) \cos(A-B) - 2 \sin C \cos C$$

$$= 2 \sin(\pi - C) \cos(A-B) - 2 \sin C \cos[\pi - (A+B)]$$

$$= 2 \sin C \cos(A-B) + 2 \sin C \cos(A+B)$$

$$= 2 \sin C [\cos(A-B) + \cos(A+B)]$$

$$= 2 \sin C \cdot 2 \cos\left(\frac{A-B+A+B}{2}\right) \cos\left(\frac{A-B-A-B}{2}\right)$$

$$= 4 \sin C \cos A \cos B$$

$$= 4 \cos A \cos B \sin C$$

$$= \text{R.H.S.}$$

$$\text{ii) } \cos A + \cos B + \cos C = 1 + 4 \sin\frac{A}{2} \sin\frac{B}{2} \sin\frac{C}{2}$$

**Solution :** L.H.S =  $\cos A + \cos B + \cos C$

$$= 2 \cos\left(\frac{A+B}{2}\right) \cos\left(\frac{A-B}{2}\right) + 1 - 2 \sin^2\frac{C}{2}$$

$$= 2 \cos\left(\frac{\pi - C}{2}\right) \cos\left(\frac{A-B}{2}\right) + 1 - 2 \sin^2\frac{C}{2}$$

$$\begin{aligned}
 &= 1 + 2 \sin \frac{C}{2} \cos \left( \frac{A-B}{2} \right) - 2 \sin^2 \frac{C}{2} \\
 &= 1 + 2 \sin \frac{C}{2} \left[ \cos \left( \frac{A-B}{2} \right) - \sin \frac{C}{2} \right] \\
 &= 1 + 2 \sin \frac{C}{2} \left[ \cos \left( \frac{A-B}{2} \right) - \sin \left( \frac{\pi}{2} - \frac{A+B}{2} \right) \right] \\
 &= 1 + 2 \sin \frac{C}{2} \left[ \cos \left( \frac{A-B}{2} \right) - \cos \left( \frac{A+B}{2} \right) \right] \\
 &= 1 + 2 \sin \frac{C}{2} \cdot 2 \sin \left( \frac{A-B+A+B}{4} \right) \sin \left( \frac{A+B-A+B}{4} \right) \\
 &= 1 + 4 \sin \frac{C}{2} \sin \frac{A}{2} \sin \frac{B}{2} \\
 &= 1 + 4 \sin \frac{A}{2} \sin \frac{B}{2} \sin \frac{C}{2} \\
 &= \text{R.H.S.}
 \end{aligned}$$

iii)  $\sin^2 A + \sin^2 B - \sin^2 C = 2 \sin A \sin B \sin C$

**Solution :** L.H.S. =  $\sin^2 A + \sin^2 B - \sin^2 C$

$$\begin{aligned}
 &= \frac{1 - \cos 2A}{2} + \frac{1 - \cos 2B}{2} - \sin^2 C \\
 &= \frac{1}{2} [2 - \cos 2A - \cos 2B] - \sin^2 C \\
 &= 1 - \frac{1}{2} [\cos 2A + \cos 2B] - \sin^2 C \\
 &= 1 - \frac{1}{2} \cdot 2 \cos \left( \frac{2A+2B}{2} \right) \cos \left( \frac{2A-2B}{2} \right) - \sin^2 C \\
 &= 1 - \sin^2 C - \cos(A+B) + \cos(A-B) \\
 &= \cos^2 C - \cos[\pi - C] \cos(A-B) \\
 &= \cos^2 C + \cos C \cos(A-B) \\
 &= \cos C [\cos C + \cos(A-B)] \\
 &= \cos C [\cos[\pi - (A+B)] + \cos(A-B)] \\
 &= \cos C [-\cos(A+B) + \cos(A-B)] \\
 &= \cos C [\cos(A-B) - \cos(A+B)]
 \end{aligned}$$

$$\begin{aligned}
 &= \cos C \cdot 2 \sin \left( \frac{A-B+A+B}{2} \right) \sin \left( \frac{A+B-A+B}{2} \right) \\
 &= 2 \cos C \sin A \sin B \\
 &= 2 \sin A \sin B \cos C \\
 &= \text{R. H.S.}
 \end{aligned}$$

iv)  $\cot A \cot B + \cot B \cot C + \cot C \cot A = 1$

**Solution :** In  $\triangle ABC$ ,  $A + B + C = \pi$

$$\begin{aligned}
 \therefore A + B &= \pi - C \\
 \therefore \tan(A+B) &= \tan(\pi - C) \\
 \therefore \frac{\tan A + \tan B}{1 - \tan A \tan B} &= \tan(\pi - C) \\
 \therefore \tan A + \tan B &= -\tan C + \tan A \tan B \tan C \\
 \therefore \tan A + \tan B + \tan C &= \tan A \tan B \tan C \\
 \therefore \frac{1}{\cot A} + \frac{1}{\cot B} + \frac{1}{\cot C} &= \frac{1}{\cot A} \cdot \frac{1}{\cot B} \cdot \frac{1}{\cot C} \\
 \therefore \cot A \cot B + \cot B \cot C + \cot C \cot A &= 1
 \end{aligned}$$

v)  $\tan \frac{A}{2} \tan \frac{B}{2} + \tan \frac{B}{2} \tan \frac{C}{2} + \tan \frac{C}{2} \tan \frac{A}{2} = 1$

**Solution :** In  $\triangle ABC$ ,  $A + B + C = \pi$

$$\begin{aligned}
 \therefore A + B &= \pi - C \quad \therefore \frac{A+B}{2} = \frac{\pi - C}{2} = \frac{\pi}{2} - \frac{C}{2} \\
 \tan \left( \frac{A}{2} + \frac{B}{2} \right) &= \tan \left( \frac{\pi}{2} - \frac{C}{2} \right) \\
 \therefore \frac{\tan \frac{A}{2} + \tan \frac{B}{2}}{1 - \tan \frac{A}{2} \tan \frac{B}{2}} &= \cot \frac{C}{2} \\
 \therefore \frac{\tan \frac{A}{2} + \tan \frac{B}{2}}{1 - \tan \frac{A}{2} \tan \frac{B}{2}} &= \frac{1}{\tan \frac{C}{2}} \\
 \therefore \left[ \tan \frac{A}{2} + \tan \frac{B}{2} \right] \tan \frac{C}{2} &= 1 - \tan \frac{A}{2} \tan \frac{B}{2} \\
 \therefore \tan \frac{A}{2} \tan \frac{C}{2} + \tan \frac{B}{2} \tan \frac{C}{2} &= 1 - \tan \frac{A}{2} \tan \frac{B}{2} \\
 \therefore \tan \frac{A}{2} \tan \frac{C}{2} + \tan \frac{B}{2} \tan \frac{C}{2} + \tan \frac{A}{2} \tan \frac{B}{2} &= 1
 \end{aligned}$$

$$\text{vi) } \frac{\cos A - \cos B + \cos C + 1}{\cos A + \cos B + \cos C - 1} = \cot \frac{A}{2} \cot \frac{C}{2}$$

$$= \cot \frac{C}{2} \cdot \frac{2 \sin \frac{B}{2} \cos \frac{A}{2}}{2 \sin \frac{A}{2} \sin \frac{B}{2}}$$

$$\text{Solution : L.H.S.} = \frac{\cos A - \cos B + \cos C + 1}{\cos A + \cos B + \cos C - 1}$$

$$= \frac{[\cos A - \cos B] + [1 + \cos C]}{[\cos A + \cos B] - [1 - \cos C]}$$

$$= \cot \frac{C}{2} \frac{\cos \frac{A}{2}}{\sin \frac{A}{2}}$$

$$= \frac{2 \sin \left( \frac{A+B}{2} \right) \sin \left( \frac{B-A}{2} \right) + 2 \cos^2 \frac{C}{2}}{2 \cos \left( \frac{A+B}{2} \right) \cos \left( \frac{A-B}{2} \right) + \left( -2 \sin^2 \frac{C}{2} \right)}$$

$$= \cot \frac{C}{2} \cot \frac{A}{2}$$

$$= \text{R.H.S.}$$

$$= \frac{2 \sin \left( \frac{\pi - C}{2} \right) \sin \left( \frac{B-A}{2} \right) + 2 \cos^2 \frac{C}{2}}{2 \cos \left( \frac{\pi - C}{2} \right) \cos \left( \frac{A-B}{2} \right) + \left( -2 \sin^2 \frac{C}{2} \right)}$$

### EXERCISE 3.5

In  $\triangle ABC$ ,  $A + B + C = \pi$  show that

$$= \frac{2 \cos \frac{C}{2} \sin \left( \frac{B-A}{2} \right) + 2 \cos^2 \frac{C}{2}}{2 \sin \frac{C}{2} \cos \left( \frac{A+B}{2} \right) - 2 \sin^2 \frac{C}{2}}$$

$$1) \cos 2A + \cos 2B + \cos 2C = -1 - 4 \cos A \cos B \cos C$$

$$= \frac{\cos \frac{C}{2} \left[ \sin \left( \frac{B-A}{2} \right) + \cos \frac{C}{2} \right]}{\sin \frac{C}{2} \left[ \cos \left( \frac{A+B}{2} \right) - \sin \frac{C}{2} \right]}$$

$$2) \sin A + \sin B + \sin C = 4 \cos \frac{A}{2} \cos \frac{B}{2} \cos \frac{C}{2}$$

$$= \cot \frac{C}{2} \frac{\left[ \sin \left( \frac{A+B}{2} \right) + \sin \left( \frac{B-A}{2} \right) \right]}{\left[ \cos \left( \frac{A-B}{2} \right) - \sin \left( \frac{\pi - A+B}{2} \right) \right]}$$

$$3) \cos A + \cos B - \cos C = 4 \cos \frac{A}{2} \cos \frac{B}{2} \sin \frac{C}{2} - 1$$

$$= \cot \frac{C}{2} \frac{\sin \left( \frac{A+B}{2} \right) + \sin \left( \frac{B-A}{2} \right)}{\cos \left( \frac{A-B}{2} \right) - \cos \left( \frac{A+B}{2} \right)}$$

$$4) \sin^2 A + \sin^2 B + \sin^2 C = 2 \sin A \sin B \cos C$$

$$= \cot \frac{C}{2} \cdot \frac{2 \sin \frac{\left( \frac{A+B}{2} + \frac{B-A}{2} \right)}{2} \cos \frac{\left( \frac{A+B}{2} - \frac{B-A}{2} \right)}{2}}{2 \sin \frac{\left( \frac{A-B}{2} + \frac{A+B}{2} \right)}{2} \sin \frac{\left( \frac{A+B}{2} - \frac{A-B}{2} \right)}{2}}$$

$$5) \sin^2 \frac{A}{2} + \sin^2 \frac{B}{2} - \sin^2 \frac{C}{2} = 1 - 2 \cos \frac{A}{2} \cos \frac{B}{2} \sin \frac{C}{2}$$

$$6) \tan \frac{A}{2} \tan \frac{B}{2} + \tan \frac{B}{2} \tan \frac{C}{2} + \tan \frac{C}{2} \tan \frac{A}{2} = 1$$

$$7) \cot \frac{A}{2} + \cot \frac{B}{2} + \cot \frac{C}{2} = \cot \frac{A}{2} \cot \frac{B}{2} \cot \frac{C}{2}$$

$$8) \tan 2A + \tan 2B + \tan 2C = \tan 2A \tan 2B \tan 2C$$

$$9) \cos^2 A + \cos^2 B - \cos^2 C = 1 - 2 \sin A \sin B \cos C$$



**Let's Remember**

1)  $\cos (A - B) = \cos A \cos B + \sin A \sin B$

2)  $\cos (A + B) = \cos A \cos B - \sin A \sin B$

3)  $\sin (A + B) = \sin A \cos B + \cos A \sin B$

4)  $\sin (A - B) = \sin A \cos B - \cos A \sin B$

5)  $\cos \left( \frac{\pi}{2} - \theta \right) = \sin \theta$ ,  $\cos \left( \frac{\pi}{2} + \theta \right) = -\sin \theta$ ,  
 $\tan \left( \frac{\pi}{2} - \theta \right) = \cot \theta$ ,  $\tan \left( \frac{\pi}{2} + \theta \right) = -\cot \theta$

6)  $\sin \left( \frac{\pi}{2} + \theta \right) = \cos \theta$ ,  $\cos \left( \frac{\pi}{2} + \theta \right) = -\sin \theta$ ,  
 $\tan \left( \frac{\pi}{2} + \theta \right) = -\cot \theta$

7)  $\tan (A + B) = \frac{\tan A + \tan B}{1 - \tan A \tan B}$

8)  $\tan (A - B) = \frac{\tan A - \tan B}{1 + \tan A \tan B}$

9)  $\sin (\pi - \theta) = \sin \theta$ ,  $\cos (\pi - \theta) = -\cos \theta$ ,  
 $\tan (\pi - \theta) = -\tan \theta$

10)  $\sin (\pi + \theta) = -\sin \theta$ ,  $\cos (\pi + \theta) = -\cos \theta$ ,  
 $\tan (\pi + \theta) = \tan \theta$

11)  $\sin \left( \frac{3\pi}{2} - \theta \right) = -\cos \theta$ ,  $\cos \left( \frac{3\pi}{2} - \theta \right) = \sin \theta$ ,  
 $\tan \left( \frac{3\pi}{2} - \theta \right) = -\cot \theta$

12)  $\sin \left( \frac{3\pi}{2} + \theta \right) = \cos \theta$ ,  $\cos \left( \frac{3\pi}{2} + \theta \right) = -\sin \theta$ ,  
 $\tan \left( \frac{3\pi}{2} + \theta \right) = -\cot \theta$

13)  $\sin (2\pi - \theta) = -\sin \theta$ ,  $\cos (2\pi - \theta) = \cos \theta$ ,  
 $\tan (2\pi - \theta) = -\tan \theta$

14)  $\sin 2\theta = 2\sin \theta \cos \theta = \frac{2 \tan \theta}{1 + \tan^2 \theta}$

$\cos 2\theta = \cos^2 \theta - \sin^2 \theta = 2\cos^2 \theta - 1$   
 $= 1 - 2\sin^2 \theta = \frac{1 - \tan^2 \theta}{1 + \tan^2 \theta}$

$\tan 2\theta = \frac{2 \tan \theta}{1 - \tan^2 \theta}$

15)  $\sin 3\theta = 3 \sin \theta - 4 \sin^3 \theta$

$\cos 3\theta = 4\cos^3 \theta - 3\cos \theta$

$\tan 3\theta = \frac{3 \tan \theta - \tan^3 \theta}{1 - 3 \tan^2 \theta}$

16)  $\sin \frac{\theta}{2} = 2 \sin \frac{\theta}{4} \cos \frac{\theta}{4} = \frac{2 \tan \frac{\theta}{4}}{1 + \tan^2 \frac{\theta}{4}}$

$\cos \frac{\theta}{2} = \cos^2 \frac{\theta}{4} - \sin^2 \frac{\theta}{4} = 2\cos^2 \frac{\theta}{4} - 1$

$= 1 - 2\sin^2 \frac{\theta}{4} = \frac{1 - \tan^2 \frac{\theta}{4}}{1 + \tan^2 \frac{\theta}{4}}$

$\tan \frac{\theta}{2} = \frac{2 \tan \frac{\theta}{4}}{1 - \tan^2 \frac{\theta}{4}}$

17)  $1 + \cos \theta = 2\cos^2 \frac{\theta}{2}$ ,  $1 - \cos \theta = 2\sin^2 \frac{\theta}{2}$

$1 + \cos 2\theta = 2\cos^2 \theta$ ,  $1 - \cos 2\theta = 2\sin^2 \theta$

18)  $\sin C + \sin D = 2 \sin \left( \frac{C+D}{2} \right) \cos \left( \frac{C-D}{2} \right)$

$\sin C - \sin D = 2 \cos \left( \frac{C+D}{2} \right) \sin \left( \frac{C-D}{2} \right)$

$\cos C + \cos D = 2 \cos \left( \frac{C+D}{2} \right) \cos \left( \frac{C-D}{2} \right)$

$\cos C - \cos D = -2 \sin \left( \frac{C+D}{2} \right) \sin \left( \frac{C-D}{2} \right)$

$\cos C - \cos D = 2 \sin \left( \frac{C+D}{2} \right) \sin \left( \frac{D-C}{2} \right)$

$$19) \begin{aligned} 2 \sin A \cos B &= \sin(A+B) + \sin(A-B) \\ 2 \cos A \sin B &= \sin(A+B) - \sin(A-B) \\ 2 \cos A \cos B &= \cos(A+B) + \cos(A-B) \\ 2 \sin A \sin B &= \cos(A-B) - \cos(A+B) \end{aligned}$$

20) For  $\triangle ABC$ ,

$$\begin{aligned} \sin(A+B) &= \sin C, \sin(B+C) = \sin A \\ \sin(A+C) &= \sin B \end{aligned}$$

$$\begin{aligned} \cos(A+B) &= -\cos C, \cos(B+C) = -\cos A \\ \cos(A+C) &= -\cos B \end{aligned}$$

$$\begin{aligned} \sin\left(\frac{A+B}{2}\right) &= \cos\frac{C}{2}, \sin\left(\frac{B+C}{2}\right) \\ &= \cos\frac{A}{2}, \sin\left(\frac{A+C}{2}\right) = \cos\frac{B}{2} \end{aligned}$$

$$\begin{aligned} \cos\left(\frac{A+B}{2}\right) &= \sin\frac{C}{2}, \cos\left(\frac{B+C}{2}\right) \\ &= \sin\frac{A}{2}, \cos\left(\frac{A+C}{2}\right) = \sin\frac{B}{2} \end{aligned}$$

**Activity :**

**Verify the following.**

$$i) \sin 18^\circ = \sin \frac{\pi}{10} = \frac{\sqrt{5}-1}{4} = \cos 72^\circ = \cos \frac{2\pi}{5}$$

$$ii) \cos 36^\circ = \cos \frac{\pi}{5} = \frac{\sqrt{5}+1}{4} = \sin 54^\circ = \sin \left(\frac{3\pi}{10}\right)$$

$$iii) \sin 72^\circ = \sin \frac{2\pi}{5} = \sqrt{\frac{10+2\sqrt{5}}{4}} = \cos 18^\circ = \cos \frac{\pi}{10}$$

$$iv) \sin 36^\circ = \sin \frac{\pi}{5} = \sqrt{\frac{10-2\sqrt{5}}{4}} = \cos 54^\circ = \cos \frac{3\pi}{10}$$

$$v) \sin 15^\circ = \sin \frac{\pi}{12} = \frac{\sqrt{3}-1}{2\sqrt{2}} = \cos 75^\circ = \cos \frac{5\pi}{12}$$

$$vi) \cos 15^\circ = \cos \frac{\pi}{12} = \frac{\sqrt{3}+1}{2\sqrt{2}} = \sin 75^\circ = \sin \frac{5\pi}{12}$$

$$vii) \tan 15^\circ = \tan \frac{\pi}{12} = \frac{\sqrt{3}-1}{\sqrt{3}+1} = \cot 75^\circ = \cot \frac{5\pi}{12}$$

$$viii) \tan 75^\circ = \tan \frac{\pi}{12} = 2 + \sqrt{3}$$

$$= \frac{\sqrt{3}+1}{\sqrt{3}-1} = \cot 15^\circ = \cot \frac{\pi}{12}$$

$$ix) \tan(22.5^\circ) = \tan \frac{\pi}{8} = \sqrt{2} - 1 = \cot 67.5^\circ = \cot \frac{3\pi}{8}$$

$$x) \tan(67.5^\circ) = \tan \frac{3\pi}{8} = \sqrt{2} + 1 = \cot(22.5^\circ) = \cot \frac{\pi}{8}$$

### MISCELLANEOUS EXERCISE - 3

**D) Select correct option from the given alternatives.**

- The value of  $\sin(n+1)A \sin(n+2)A + \cos(n+1)A \cos(n+2)A$  is equal to  
A)  $\sin A$  B)  $\cos A$  C)  $-\cos A$  D)  $\sin 2A$
- If  $\tan A - \tan B = x$  and  $\cot B - \cot A = y$  then  $\cot(A-B) = \dots$   
A)  $\frac{1}{y} - \frac{1}{x}$  B)  $\frac{1}{x} - \frac{1}{y}$   
C)  $\frac{1}{x} + \frac{1}{y}$  D)  $\frac{xy}{x-y}$
- If  $\sin \theta = n \sin(\theta + 2\alpha)$  then  $\tan(\theta + \alpha)$  is equal to  
A)  $\frac{1+n}{2-n} \tan \alpha$  B)  $\frac{1-n}{1+n} \tan \alpha$   
C)  $\tan \alpha$  D)  $\frac{1+n}{1-n} \tan \alpha$

- 4) The value of  $\frac{\cos \theta}{1 + \sin \theta}$  is equal to.....
- A)  $\tan\left(\frac{\theta}{2} - \frac{\pi}{4}\right)$       B)  $\tan\left(-\frac{\pi}{4} - \frac{\theta}{2}\right)$   
 C)  $\tan\left(\frac{\pi}{4} - \frac{\theta}{2}\right)$       D)  $\tan\left(\frac{\pi}{4} + \frac{\theta}{2}\right)$
- 5) The value of  $\cos A \cos(60^\circ - A) \cos(60^\circ + A)$  is equal to.....
- A)  $\frac{1}{2} \cos 3A$       B)  $\cos 3A$   
 C)  $\frac{1}{4} \cos 3A$       D)  $4 \cos 3A$
- 6) The value of  $\sin \frac{\pi}{14} \sin \frac{3\pi}{14} \sin \frac{5\pi}{14} \sin \frac{7\pi}{14} \sin \frac{9\pi}{14} \sin \frac{11\pi}{14} \sin \frac{13\pi}{14}$  is ....
- A)  $\frac{1}{16}$       B)  $\frac{1}{64}$       C)  $\frac{1}{128}$       D)  $\frac{1}{256}$
- 7) If  $\alpha + \beta + \kappa = \pi$  then the value of  $\sin^2 \alpha + \sin^2 \beta - \sin^2 \kappa$  is equal to.....
- A)  $2 \sin \alpha$       B)  $2 \sin \alpha \cos \beta \sin \kappa$   
 C)  $2 \sin \alpha \sin \beta \cos \kappa$       D)  $2 \sin \alpha \sin \beta \sin \kappa$
- 8) Let  $0 < A, B < \frac{\pi}{2}$  satisfying the equation  $3 \sin^2 A + 2 \sin^2 B = 1$  and  $3 \sin 2A - 2 \sin 2B = 0$  then  $A + 2B$  is equal to....
- A)  $\pi$       B)  $\frac{\pi}{2}$       C)  $\frac{\pi}{4}$       D)  $2\pi$
- 9) In  $\Delta ABC$  if  $\cot A \cot B \cot C > 0$  then the triangle is....
- A) Acute angled      B) right angled  
 C) obtuse angled  
 D) isosceles right angled
- 10) The numerical value of  $\tan 20^\circ \tan 80^\circ \cot 50^\circ$  is equal to.....
- A)  $\sqrt{3}$       B)  $\frac{1}{\sqrt{3}}$       C)  $2\sqrt{3}$       D)  $\frac{1}{2\sqrt{3}}$
- II) Prove the following.**
- 1)  $\tan 20^\circ \tan 80^\circ \cot 50^\circ = \sqrt{3}$
- 2) If  $\sin \alpha \sin \beta - \cos \alpha \cos \beta + 1 = 0$  then prove  $\cot \alpha \tan \beta = -1$
- 3)  $\cos \frac{2\pi}{15} \cos \frac{4\pi}{15} \cos \frac{8\pi}{15} \cos \frac{16\pi}{15} = \frac{1}{16}$
- 4)  $(1 + \cos \frac{\pi}{8})(1 + \cos \frac{3\pi}{8})(1 + \cos \frac{5\pi}{8})(1 + \cos \frac{7\pi}{8}) = \frac{1}{8}$
- 5)  $\cos 12^\circ + \cos 84^\circ + \cos 156^\circ + \cos 132^\circ = -\frac{1}{2}$
- 6)  $\cos\left(\frac{\pi}{4} + x\right) + \cos\left(\frac{\pi}{4} - x\right) = \sqrt{2} \cos x$
- 7)  $\frac{\sin 5x - 2 \sin 3x + \sin x}{\cos 5x - \cos x} = \tan x$
- 8)  $\sin^2 6x - \sin^2 4x = \sin 2x \sin 10x$
- 9)  $\cos^2 2x - \cos^2 6x = \sin 4x \sin 8x$
- 10)  $\cot 4x (\sin 5x + \sin 3x) = \cot x (\sin 5x - \sin 3x)$
- 11)  $\frac{\cos 9x - \cos 5x}{\sin 17x - \sin 3x} = -\frac{\sin 2x}{\cos 10x}$
- 12) If  $\sin 2A = \lambda \sin 2B$  then prove that  $\frac{\tan(A+B)}{\tan(A-B)} = \frac{\lambda+1}{\lambda-1}$
- 13)  $\frac{2 \cos 2A + 1}{2 \cos 2A - 1} = \tan(60^\circ + A) \tan(60^\circ - A)$
- 14)  $\tan A + \tan(60^\circ + A) + \tan(120^\circ + A) = -\tan 3A$
- 15)  $3 \tan^6 10^\circ - 27 \tan^4 10^\circ + 33 \tan^2 10^\circ = 1$

16)  $\operatorname{cosec} 48^\circ + \operatorname{cosec} 96^\circ +$   
 $\operatorname{cosec} 192^\circ + \operatorname{cosec} 384^\circ = 0$

17)  $3(\sin x - \cos x)^4 + 6(\sin x + \cos x)^2 +$   
 $4(\sin^6 x + \cos^6 x) = 13$

18)  $\tan A + 2 \tan 2A + 4 \tan 4A + 8 \cot 8A = \cot A$

19) If  $A + B + C = \frac{3\pi}{2}$  then  $\cos 2A +$   
 $\cos 2B + \cos 2C = 1 - 4 \sin A \sin B \sin C$

20) In any triangle ABC,  $\sin A - \cos B = \cos C$   
then  $\angle B = \pi/2$

21)  $\frac{\tan^3 x}{1 + \tan^2 x} + \frac{\cot^3 x}{1 + \cot^2 x} = \sec x \operatorname{cosec} x - 2 \sin x \cos x$

22)  $\sin 20^\circ \sin 40^\circ \sin 80^\circ = \frac{\sqrt{3}}{8}$

23)  $\sin 18^\circ = \frac{\sqrt{5}-1}{4}$

24)  $\cos 36^\circ = \frac{\sqrt{5}+1}{4}$

25)  $\sin 36^\circ = \sqrt{\frac{10-2\sqrt{5}}{4}}$

26)  $\sin \frac{\pi}{8} = \frac{1}{2} \sqrt{2-\sqrt{2}}$

27)  $\tan \frac{\pi}{8} = \sqrt{2}-1$

28)  $\tan 6^\circ \tan 42^\circ \tan 66^\circ \tan 78^\circ = 1$

29)  $\sin 47^\circ + \sin 61^\circ - \sin 11^\circ - \sin 2^\circ = \cos 7^\circ$

30)  $\sqrt{3} \operatorname{cosec} 20^\circ - \sec 20^\circ = 4$

31) In  $\triangle ABC$ ,  $\angle C = \frac{2\pi}{3}$  then prove that  
 $\cos^2 A + \cos^2 B - \cos A \cos B = \frac{3}{4}$



# 4 Determinants and Matrices

## Let's Study

- Definition and Expansion of Determinants
- Minors and Co-factors of determinants
- Properties of Determinants
- Applications of Determinants
- Introduction and types of Matrices
- Operations on Matrices
- Properties of related matrices

$$\begin{array}{cc}
 \left| \begin{array}{cc} a & b \\ c & d \end{array} \right| & \begin{array}{l} \leftarrow 1^{\text{st}} \text{ row} \\ \leftarrow 2^{\text{nd}} \text{ row} \end{array} \\
 \begin{array}{c} \uparrow \\ 1^{\text{st}} \\ \text{column} \end{array} & \begin{array}{c} \uparrow \\ 2^{\text{nd}} \\ \text{column} \end{array}
 \end{array}$$

The value of the determinant  $\begin{vmatrix} a & b \\ c & d \end{vmatrix}$  is  $ad - bc$ .

## SOLVED EXAMPLES

### 4.1 Introduction

We have learnt to solve simultaneous equations in two variables using determinants. We will now learn more about the determinants because they are useful in Engineering applications, and Economics, etc.

The concept of a determinant was discussed by the German Mathematician G.W. Leibnitz (1676-1714) and Cramer (1750) developed the rule for solving linear equations using determinants.

## Let's Recall

#### 4.1.1 Value of a Determinant

In standard X we have studied a method of solving simultaneous equations in two unknowns using determinants of order two. In this chapter, we shall study determinants of order three.

The representation  $\begin{vmatrix} a & b \\ c & d \end{vmatrix}$  is defined as the

determinant of order two. Numbers a, b, c, d are called elements of the determinant. In this arrangement, there are two rows and two columns.

**Ex.** Evaluate i)  $\begin{vmatrix} 7 & 9 \\ -4 & 3 \end{vmatrix}$       ii)  $\begin{vmatrix} \cos \theta & \sin \theta \\ -\sin \theta & \cos \theta \end{vmatrix}$

iii)  $\begin{vmatrix} 4 & i \\ -2i & 7 \end{vmatrix}$  where  $i^2 = -1$       iv)  $\begin{vmatrix} \log_4^2 & \log_4^2 \\ 2 & 4 \end{vmatrix}$

#### Solution :

i)  $\begin{vmatrix} 7 & 9 \\ -4 & 3 \end{vmatrix} = 7 \times 3 - (-4) \times 9 = 21 + 36 = 57$

ii)  $\begin{vmatrix} \cos \theta & \sin \theta \\ -\sin \theta & \cos \theta \end{vmatrix} = \cos^2 \theta - (-\sin^2 \theta)$   
 $= \cos^2 \theta + \sin^2 \theta = 1$

iii)  $\begin{vmatrix} 4 & i \\ -2i & 7 \end{vmatrix} = 4 \times 7 - (-2i) \times i = 28 + 2i^2$   
 $= 28 + 2(-1) \quad [ \because i^2 = -1 ]$   
 $= 28 - 2 = 26$

iv)  $\begin{vmatrix} \log_4^2 & \log_4^2 \\ 2 & 4 \end{vmatrix} = 4 \times \log_4 2 - 2 \times \log_4^2$   
 $= \log_4 2^4 - \log_4 2^2$

$$\begin{aligned}
 &= \log_4 16 - \log_4 4 \\
 &= 2 \log_4 4 - \log_4 4 \\
 &= 2 \times 1 - 1 = 2 - 1 = 1
 \end{aligned}$$

$$D = \begin{vmatrix} a_{11} & a_{12} & a_{13} \\ a_{21} & a_{22} & a_{23} \\ a_{31} & a_{32} & a_{33} \end{vmatrix}$$



### Let's Understand

#### 4.1.2 Determinant of order 3

**Definition** - A determinant of order 3 is a square arrangement of 9 elements enclosed between two vertical bars. The elements are arranged in 3 rows and 3 columns as given below.

$$\begin{vmatrix} a_{11} & a_{12} & a_{13} \\ a_{21} & a_{22} & a_{23} \\ a_{31} & a_{32} & a_{33} \end{vmatrix} \begin{matrix} R_1 \\ R_2 \\ R_3 \end{matrix} \begin{matrix} R_1 \text{ are the rows} \\ C_j \text{ are the column} \\ R_3 \end{matrix} \\
 \begin{matrix} C_1 \\ C_2 \\ C_3 \end{matrix}$$

Here  $a_{ij}$  represents the element in  $i^{\text{th}}$  row and  $j^{\text{th}}$  column of the determinant.

e.g.  $a_{31}$  represents the element in 3<sup>rd</sup> row and 1<sup>st</sup> column.

In general, we denote determinant by Capital Letters or by  $\Delta$  (delta).

We can write the rows and columns separately. e.g. here the 2<sup>nd</sup> row is  $[a_{21} \ a_{22} \ a_{23}]$  and 3<sup>rd</sup> column is

$$\begin{bmatrix} a_{13} \\ a_{23} \\ a_{33} \end{bmatrix}$$

#### Expansion of Determinant

We will find the value or expansion of a 3x3 determinant. We give here the expansion by the 1<sup>st</sup> row of the determinant D.

There are six ways of expanding a determinant of order 3, corresponding to each of three rows ( $R_1, R_2, R_3$ ) and three columns ( $C_1, C_2, C_3$ ).

The determinant can be expanded as follows:

$$D = a_{11} \begin{vmatrix} a_{22} & a_{23} \\ a_{32} & a_{33} \end{vmatrix} - a_{12} \begin{vmatrix} a_{21} & a_{23} \\ a_{31} & a_{33} \end{vmatrix} + a_{13} \begin{vmatrix} a_{21} & a_{22} \\ a_{31} & a_{32} \end{vmatrix}$$

#### SOLVED EXAMPLES

Evaluate:

i)  $\begin{vmatrix} 3 & -4 & 5 \\ 1 & 1 & -2 \\ 2 & 3 & -1 \end{vmatrix}$

ii)  $\begin{vmatrix} \sec \theta & \tan \theta & 0 \\ \tan \theta & \sec \theta & 0 \\ 0 & 0 & 1 \end{vmatrix}$

iii)  $\begin{vmatrix} 2-i & 3 & -1 \\ 3 & 2-i & 0 \\ 2 & -1 & 2-i \end{vmatrix}$  where  $i = \sqrt{-1}$

**Solution :**

$$\begin{aligned}
 \text{i) } \begin{vmatrix} 3 & -4 & 5 \\ 1 & 1 & -2 \\ 2 & 3 & -1 \end{vmatrix} &= 3 \begin{vmatrix} 1 & -2 \\ 3 & -1 \end{vmatrix} - (-4) \begin{vmatrix} 1 & -2 \\ 2 & -1 \end{vmatrix} \\
 &+ 5 \begin{vmatrix} 1 & 1 \\ 2 & 3 \end{vmatrix} \\
 &= 3(-1+6) + 4(-1+4) + 5(3-2) \\
 &= 3 \times 5 + 4 \times 3 + 5 \times 1 \\
 &= 15 + 12 + 5 \\
 &= 32
 \end{aligned}$$

$$\begin{aligned}
 \text{ii) } & \begin{vmatrix} \sec \theta & \tan \theta & 0 \\ \tan \theta & \sec \theta & 0 \\ 0 & 0 & 1 \end{vmatrix} \\
 &= \sec \theta \begin{vmatrix} \sec \theta & 0 \\ 0 & 1 \end{vmatrix} - \tan \theta \begin{vmatrix} \tan \theta & 0 \\ 0 & 1 \end{vmatrix} \\
 &+ 0 \begin{vmatrix} \tan \theta & \sec \theta \\ 0 & 0 \end{vmatrix} \\
 &= \sec \theta (\sec \theta - 0) - \tan \theta (\tan \theta - 0) + 0 \\
 &= \sec^2 \theta - \tan^2 \theta \\
 &= 1
 \end{aligned}$$

$$\begin{aligned}
 \text{iii) } & \begin{vmatrix} 2-i & 3 & -1 \\ 3 & 2-i & 0 \\ 2 & -1 & 2-i \end{vmatrix} \\
 &= (2-i)[(2-i)^2 - 0] - 3[3(2-i) - 0] \\
 &\quad - 1[-3 - 2(2-i)] \\
 &= (2-i)^3 - 9(2-i) + 3 + 2(2-i) \\
 &= 8 - 12i + 6i^2 - i^3 - 18 + 9i + 3 + 4 - 2i \\
 &= 8 - 12i + 6(-1) + i - 18 + 9i + 3 + 4 - 2i \\
 &\quad \text{(since } i^2 = -1) \\
 &= 8 - 6 - 18 + 7 - 12i + 9i - 2i + i \\
 &= -9 - 4i
 \end{aligned}$$



### Let's Learn

#### 4.1.3 Minors and Cofactors of elements of determinants

Let  $A = \begin{vmatrix} a_{11} & a_{12} & a_{13} \\ a_{21} & a_{22} & a_{23} \\ a_{31} & a_{32} & a_{33} \end{vmatrix}$  be a given determinant.

#### Definitions

**The minor of  $a_{ij}$**  - It is defined as the determinant obtained by eliminating the  $i^{\text{th}}$  row and  $j^{\text{th}}$  column of  $A$ . That is the row and the column that contain the element  $a_{ij}$  are omitted. We denote the minor of the element  $a_{ij}$  by  $M_{ij}$ .

In case of above determinant  $A$

$$\text{Minor of } a_{11} = M_{11} = \begin{vmatrix} a_{22} & a_{23} \\ a_{32} & a_{33} \end{vmatrix} = a_{22} \cdot a_{33} - a_{32} \cdot a_{23}$$

$$\text{Minor of } a_{12} = M_{12} = \begin{vmatrix} a_{21} & a_{23} \\ a_{31} & a_{33} \end{vmatrix} = a_{21} \cdot a_{33} - a_{31} \cdot a_{23}$$

$$\text{Minor of } a_{13} = M_{13} = \begin{vmatrix} a_{21} & a_{22} \\ a_{31} & a_{32} \end{vmatrix} = a_{21} \cdot a_{32} - a_{31} \cdot a_{22}$$

Similarly we can find minors of other elements.

#### Cofactor of $a_{ij}$ -

$$\text{cofactor of } a_{ij} = (-1)^{i+j} \text{ minor of } a_{ij} = C_{ij}$$

$$\therefore \text{Cofactor of element } a_{ij} = C_{ij} = (-1)^{i+j} M_{ij}$$

The same definition can also be given for

elements in  $2 \times 2$  determinant. Thus in  $\begin{vmatrix} a & b \\ c & d \end{vmatrix}$

The minor of  $a$  is  $d$ .

The minor of  $b$  is  $c$ .

The minor of  $c$  is  $b$ .

The minor of  $d$  is  $a$ .

#### SOLVED EXAMPLES

**Ex. 1)** Find Minors and Cofactors of the elements of determinant

$$\text{i) } \begin{vmatrix} 2 & -3 \\ 4 & 7 \end{vmatrix}$$

$$\text{Solution : Here } \begin{vmatrix} a_{11} & a_{12} \\ a_{21} & a_{22} \end{vmatrix} = \begin{vmatrix} 2 & -3 \\ 4 & 7 \end{vmatrix}$$

$$M_{11} = 7$$

$$C_{11} = (-1)^{1+1} M_{11} = (-1)^{1+1} \cdot 7 = 7$$

$$M_{12} = 4$$

$$C_{11} = (-1)^{1+1} M_{12} = (-1)^{1+2} \cdot 4 = -4$$

$$M_{21} = -3$$

$$C_{21} = (-1)^{1+1} M_{21} = (-1)^{2+1} \cdot (-3) = 3$$

$$M_{22} = 2$$

$$C_{22} = (-1)^{1+1} M_{22} = (-1)^{2+2} \cdot 2 = 2$$

$$\text{ii) } \begin{vmatrix} 1 & 2 & -3 \\ -2 & 0 & 4 \\ 5 & -1 & 3 \end{vmatrix}$$

**Solution :**

$$\text{Here } \begin{vmatrix} a_{11} & a_{12} & a_{13} \\ a_{21} & a_{22} & a_{23} \\ a_{31} & a_{32} & a_{33} \end{vmatrix} = \begin{vmatrix} 1 & 2 & -3 \\ -2 & 0 & 4 \\ 5 & -1 & 3 \end{vmatrix}$$

$$M_{11} = \begin{vmatrix} 0 & 4 \\ -1 & 3 \end{vmatrix} = 0 + 4 = 4$$

$$C_{11} = (-1)^{1+1} M_{11} = (-1)^{1+1} \cdot 4 = 4$$

$$M_{12} = \begin{vmatrix} -2 & 4 \\ 5 & 3 \end{vmatrix} = -6 - 20 = -26$$

$$C_{12} = (-1)^{1+2} M_{12} = (-1)^{1+2} \cdot (-26) = 26$$

$$M_{13} = \begin{vmatrix} -2 & 0 \\ 5 & -1 \end{vmatrix} = 2 - 0 = 2$$

$$C_{13} = (-1)^{1+3} M_{13} = (-1)^{1+3} \cdot 2 = 2$$

$$M_{21} = \begin{vmatrix} 2 & -3 \\ -1 & 3 \end{vmatrix} = 6 - 3 = 3$$

$$C_{21} = (-1)^{2+1} M_{21} = (-1)^{2+1} \cdot 3 = -3$$

$$M_{22} = \begin{vmatrix} 1 & -3 \\ 5 & 3 \end{vmatrix} = 3 + 15 = 18$$

$$C_{22} = (-1)^{2+2} M_{22} = (-1)^{1+1} \cdot 18 = 18$$

$$M_{23} = \begin{vmatrix} 1 & 2 \\ 5 & -1 \end{vmatrix} = -1 - 10 = -11$$

$$C_{23} = (-1)^{2+3} M_{23} = (-1)^{2+3} \cdot (-11) = 11$$

$$M_{31} = \begin{vmatrix} 2 & -3 \\ 0 & 4 \end{vmatrix} = 8 - 0 = 8$$

$$C_{31} = (-1)^{3+1} M_{31} = (-1)^{3+1} \cdot 8 = 8$$

$$M_{32} = \begin{vmatrix} 1 & -3 \\ -2 & 4 \end{vmatrix} = 4 - 6 = -2$$

$$C_{32} = (-1)^{3+2} M_{32} = (-1)^{3+2} \cdot (-2) = 2$$

$$M_{33} = \begin{vmatrix} 1 & 2 \\ -2 & 0 \end{vmatrix} = 0 + 4 = 4$$

$$C_{33} = (-1)^{3+3} M_{33} = (-1)^{3+3} \cdot 4 = 4$$

**Expansion of determinant by using Minor and cofactors of any row/column**

$$A = \begin{vmatrix} a_{11} & a_{12} & a_{13} \\ a_{21} & a_{22} & a_{23} \\ a_{31} & a_{32} & a_{33} \end{vmatrix}$$

$$= a_{11}C_{11} + a_{12}C_{12} + a_{13}C_{13} \text{ (By 1<sup>st</sup> row)}$$

$$= a_{12}C_{12} + a_{22}C_{22} + a_{32}C_{32} \text{ (By 2<sup>nd</sup> column)}$$

**Ex. 2)** Find value of x if

$$\text{i) } \begin{vmatrix} x & -1 & 2 \\ 2x & 1 & -3 \\ 3 & -4 & 5 \end{vmatrix} = -10$$

$$\therefore x(5 - 12) - (-1)(10x + 9) + 2(-8x - 3) = -10$$

$$\therefore x(-7) + (10x + 9) - 16x - 6 = -10$$

$$\therefore -7x + 10x - 16x + 9 - 6 + 10 = 0$$

$$\therefore 10x - 23x + 13 = 0$$

$$\therefore 13x = 13$$

$$\therefore x = 1$$

$$\text{ii) } \begin{vmatrix} x & 3 & 2 \\ x & x & 1 \\ 1 & 0 & 1 \end{vmatrix} = 9$$

$$\therefore x(x-0) - 3(x-1) + 2(0-x) = 9$$

$$\therefore x^2 - 3x + 3 - 2x = 9$$

$$\therefore x^2 - 5x + 3 = 9$$

$$\therefore x^2 - 5x - 6 = 0$$

$$\therefore (x-6)(x+1) = 0$$

$$\therefore x-6 = 0 \text{ or } x+1 = 0$$

$$\therefore x = 6 \text{ or } x = -1$$

**Ex. 3)** Find the value of  $\begin{vmatrix} 1 & -1 & 2 \\ -2 & 3 & 5 \\ -2 & 0 & -1 \end{vmatrix}$  by

expanding along a) 2<sup>nd</sup> row b) 3<sup>rd</sup> column and Interpret the result.

a) Expansion along the 2<sup>nd</sup> row

$$= a_{21}c_{21} + a_{22}c_{22} + a_{23}c_{23}$$

$$= -2(-1)^{2+1} \begin{vmatrix} -1 & 2 \\ 0 & -1 \end{vmatrix} + 3(-1)^{2+2} \begin{vmatrix} 1 & 2 \\ -2 & -1 \end{vmatrix}$$

$$+ 5(-1)^{2+3} \begin{vmatrix} 1 & -1 \\ -2 & 0 \end{vmatrix}$$

$$= 2(+1(-0)) + 3(-1+4) - 5(0-2)$$

$$= 2(1) + 3(3) - 5(-2)$$

$$= 2 + 9 + 10$$

$$= 21$$

b) Expansion along 3<sup>rd</sup> column

$$= a_{13}c_{13} + a_{23}c_{23} + a_{33}c_{33}$$

$$= 2(-1)^{1+3} \begin{vmatrix} -2 & 3 \\ -2 & 0 \end{vmatrix} + 5(-1)^{2+3} \begin{vmatrix} 1 & -1 \\ -2 & 0 \end{vmatrix} +$$

$$- 1(-1)^{3+3} \begin{vmatrix} 1 & -1 \\ -2 & 3 \end{vmatrix}$$

$$= 2(0 + 6) - 5(0-2) - 1(3-2)$$

$$= 2(6) - 5(-2) - 1(1)$$

$$= 12 + 10 - 1$$

$$= 22 - 1$$

$$= 21$$

**Interpretation:** From (a) and (b) it is seen that the expansion of determinant by both ways gives the same value.

### EXERCISE 4.1

Q.1) Find the value of determinant

$$\text{i) } \begin{vmatrix} 2 & -4 \\ 7 & -15 \end{vmatrix} \quad \text{ii) } \begin{vmatrix} 2i & 3 \\ 4 & -i \end{vmatrix} \quad \text{iii) } \begin{vmatrix} 3 & -4 & 5 \\ 1 & 1 & -2 \\ 2 & 3 & 1 \end{vmatrix}$$

$$\text{iv) } \begin{vmatrix} a & h & g \\ h & b & f \\ g & f & c \end{vmatrix}$$

Q.2) Find the value of x if

$$\text{i) } \begin{vmatrix} x^2 - x + 1 & x + 1 \\ x + 1 & x + 1 \end{vmatrix} = 0 \quad \text{ii) } \begin{vmatrix} x & -1 & 2 \\ 2x & 1 & -3 \\ 3 & -4 & 5 \end{vmatrix} = 29$$

$$\text{Q.3 Find } x \text{ and } y \text{ if } \begin{vmatrix} 4i & i^3 & 2i \\ 1 & 3i^2 & 4 \\ 5 & -3 & i \end{vmatrix} = x+iy \text{ where } i^2 = -1$$

Q.4) Find the minor and cofactor of element of the determinant

$$D = \begin{vmatrix} 2 & -1 & 3 \\ 1 & 2 & -1 \\ 5 & 7 & 2 \end{vmatrix}$$

Q.5) Evaluate  $A = \begin{vmatrix} 2 & -3 & 5 \\ 6 & 0 & 4 \\ 1 & 5 & -7 \end{vmatrix}$  Also find minor

and cofactor of elements in the 2<sup>nd</sup> row of determinant and verify

a)  $-a_{21} \cdot M_{21} + a_{22} \cdot M_{22} - a_{23} \cdot M_{23}$  = value of A

b)  $a_{21} C_{21} + a_{22} C_{22} + a_{23} C_{23}$  = value of A

where  $M_{21}, M_{22}, M_{23}$  are minor of  $a_{21}, a_{22}, a_{23}$  and  $C_{21}, C_{22}, C_{23}$  are cofactor of  $a_{21}, a_{22}, a_{23}$

Q.6) Find the value of determinant expanding along third column

$$\begin{vmatrix} -1 & 1 & 2 \\ -2 & 3 & -4 \\ -3 & 4 & 0 \end{vmatrix}$$

### 4.2 Properties of Determinants

In the previous section we have learnt how to expand the determinant. Now we will study some properties of determinants. They will help us to evaluate the determinant more easily.

**Let's Verify...**

**Property 1** - The value of determinant remains unchanged if its rows are turned into columns and columns are turned into rows.

Verification:

$$\begin{aligned} \text{Let } D &= \begin{vmatrix} a_1 & b_1 & c_1 \\ a_2 & b_2 & c_2 \\ a_3 & b_3 & c_3 \end{vmatrix} \\ &= a_1 (b_2 c_3 - b_3 c_2) - b_1 (a_2 c_3 - a_3 c_2) + c_1 (a_2 b_3 - a_3 b_2) \end{aligned} \quad \text{----- (i)}$$

$$\begin{aligned} \text{Let } D_1 &= \begin{vmatrix} a_1 & a_2 & a_3 \\ b_1 & b_2 & b_3 \\ c_1 & c_2 & c_3 \end{vmatrix} \\ &= a_1 (b_2 c_3 - b_3 c_2) - a_2 (b_1 c_3 - c_1 b_3) + a_3 (b_1 c_2 - c_1 b_2) \end{aligned}$$

$$\begin{aligned} &= a_1 (b_2 c_3 - b_3 c_2) - a_2 (b_1 c_3 + c_1 b_3) + a_3 (b_1 c_2 - c_1 b_2) \\ &= a_1 (b_2 c_3 - b_3 c_2) - b_1 (a_2 c_3 - a_3 c_2) + c_1 (a_2 b_3 - b_2 a_3) \end{aligned} \quad \text{----- (ii)}$$

From (i) and (ii)  $D = D_1$

**Ex.**

Let  $A = \begin{vmatrix} 1 & 2 & -1 \\ 3 & -1 & 2 \\ 0 & 2 & 1 \end{vmatrix}$

$$\begin{aligned} &= 1 \begin{vmatrix} -1 & 2 \\ 2 & 1 \end{vmatrix} - 2 \begin{vmatrix} 3 & 2 \\ 0 & 1 \end{vmatrix} - 1 \begin{vmatrix} 3 & -1 \\ 0 & 2 \end{vmatrix} \\ &= 1(-1-4) - 2(3-0) - 1(6-0) \\ &= -5 - 6 - 6 \\ &= -17 \end{aligned} \quad \text{----- (i)}$$

by interchanging rows and columns of A we get determinant  $A_1$

$$\begin{aligned} A_1 &= \begin{vmatrix} 1 & 3 & 0 \\ 2 & -1 & 2 \\ -1 & 2 & 1 \end{vmatrix} = 1 \begin{vmatrix} -1 & 2 \\ 2 & 1 \end{vmatrix} - 3 \begin{vmatrix} 2 & 2 \\ -1 & 1 \end{vmatrix} \\ &+ 0 \begin{vmatrix} 2 & -1 \\ -1 & 2 \end{vmatrix} \\ &= 1(-1-4) - 3(2+2) + 0 \\ &= -5 - 12 \\ &= -17 \end{aligned} \quad \text{----- (ii)}$$

∴  $A = A_1$  from (i) and (ii)

**Property 2** - If any two rows (or columns) of the determinant are interchanged then the value of determinant changes its sign.

The operation  $R_i \leftrightarrow R_j$  change the sign of the determinant.

**Note :** We denote the interchange of rows by  $R_i \leftrightarrow R_j$  and interchange of columns by  $C_i \leftrightarrow C_j$ .

**Property 3** - If any two rows (or columns) of a determinant are identical then the value of determinant is zero.

$R_1 \leftrightarrow R_2 \quad D = D_1$   
 then  $D_1 = -D$  ..... (property 2) ..... (I)  
 But  $R_1 = R_2$  hence  $D_1 = D$  ..... (II)  
 $\therefore$  adding I and II  
 $2D_1 = 0 \Rightarrow D_1 = 0$   
 i.e.  $D = 0$

**Property 4** - If each element of a row (or a column) of determinant is multiplied by a constant  $k$  then the value of the new determinant is  $k$  times the value of given determinant.

The operation  $R_i \rightarrow kR_i$  gives multiple of the determinant by  $k$ .

**Remark** i) Using this property we can take out any common factor from any one row (or any one column) of the given determinant

ii) If corresponding elements of any two rows (or columns) of determinant are proportional (in the same ratio) then the value of the determinant is zero.

**Property 5** - If each element of a row (or column) is expressed as the sum of two numbers then the determinant can be expressed as sum of two determinants

For example,

$$\begin{vmatrix} a_1 + x_1 & b_1 + y_1 & c_1 + z_1 \\ a_2 & b_2 & c_2 \\ a_3 & b_3 & c_3 \end{vmatrix} = \begin{vmatrix} a_1 & b_1 & c_1 \\ a_2 & b_2 & c_2 \\ a_3 & b_3 & c_3 \end{vmatrix} + \begin{vmatrix} x_1 & y_1 & z_1 \\ a_2 & b_2 & c_2 \\ a_3 & b_3 & c_3 \end{vmatrix}$$

**Property 6** - If a constant multiple of all elements of any row (or column) is added to the corresponding elements of any other row (or column) then the value of new determinant so obtained is the same as that of the original determinant. The operation  $R_i \leftrightarrow R_i + kR_j$  does not change the value of the determinant.

Verification

$$A = \begin{vmatrix} a_1 & b_1 & c_1 \\ a_2 & b_2 & c_2 \\ a_3 & b_3 & c_3 \end{vmatrix}$$

$$R_1 \rightarrow R_1 + kR_3$$

$$A_1 = \begin{vmatrix} a_1 + ka_3 & b_1 + kb_3 & c_1 + kc_3 \\ a_2 & b_2 & c_2 \\ a_3 & b_3 & c_3 \end{vmatrix}$$

Simplifying  $A_1$ , using the previous properties, we get  $A_1 = A$ .

**Ex. :** Let  $B = \begin{vmatrix} 1 & 2 & 3 \\ -1 & 2 & 0 \\ 1 & 2 & 1 \end{vmatrix} = 1(2 \cdot 0) - 2(-1 \cdot 0) + 3(-2 \cdot 2) = 2 + 2 - 12 = 4 - 12 = -8$  -----(i)

Now,  $B = \begin{vmatrix} 1 & 2 & 3 \\ -1 & 2 & 0 \\ 1 & 2 & 1 \end{vmatrix}$

$$R_1 \rightarrow R_1 + 2R_2$$

$$B_1 = \begin{vmatrix} 1 + 2(-1) & 2 + 2(2) & 3 + 2(0) \\ -1 & 2 & 0 \\ 1 & 2 & 1 \end{vmatrix}$$

$$B_1 = \begin{vmatrix} -1 & 6 & 3 \\ -1 & 2 & 0 \\ 1 & 2 & 1 \end{vmatrix} = -1(2 \cdot 0) - 6(-1 \cdot 0) + 3(-2 \cdot 2) = -2 + 6 - 12 = 6 - 14 = -8$$
 -----(ii)

From (i) and (ii)  $B = B_1$

**Remark :** If more than one operation from above are done, make sure that these operations are completed one at a time. Else there can be mistake in calculation.

**Main diagonal of determinant :** The main diagonal (principal diagonal) of determinant  $A$  is collection of entries  $a_{ij}$  where  $i = j$

OR

**Main diagonal of determinant :** The set of elements  $(a_{11}, a_{22}, a_{33}, \dots, a_{nn})$  is called the main diagonal of the determinant  $A$ .

e.g.  $D = \begin{vmatrix} a_{11} & a_{12} & a_{13} \\ a_{21} & a_{22} & a_{23} \\ a_{31} & a_{32} & a_{33} \end{vmatrix}$  here  $a_{11}, a_{22}, a_{33}$  are

element of main diagonal

**Property 7 - (Triangle property) -** If each element of a determinant above or below the main diagonal is zero then the value of the determinant is equal to product of its diagonal elements.

that is

$$\begin{vmatrix} a_1 & b_1 & c_1 \\ 0 & b_2 & c_2 \\ 0 & 0 & c_3 \end{vmatrix} = \begin{vmatrix} a_1 & 0 & 0 \\ a_2 & b_2 & 0 \\ a_3 & b_3 & c_3 \end{vmatrix} = a_1 b_2 c_3$$

**Remark :** If all elements in any row or any column of a determinant are zeros then the value of the determinant is zero.

### SOLVED EXAMPLES

**Ex. 1)** Show that

i)  $\begin{vmatrix} 101 & 202 & 303 \\ 505 & 606 & 707 \\ 1 & 2 & 3 \end{vmatrix} = 0$

$$\text{LHS} = \begin{vmatrix} 101 & 202 & 303 \\ 505 & 606 & 707 \\ 1 & 2 & 3 \end{vmatrix}$$

$$R_1 \rightarrow R_1 - R_3$$

$$= \begin{vmatrix} 100 & 200 & 300 \\ 505 & 606 & 707 \\ 1 & 2 & 3 \end{vmatrix}$$

$$= \begin{vmatrix} 100 \times 1 & 100 \times 2 & 100 \times 3 \\ 505 & 606 & 707 \\ 1 & 2 & 3 \end{vmatrix}$$

$$= 100 \begin{vmatrix} 1 & 2 & 3 \\ 505 & 606 & 707 \\ 1 & 2 & 3 \end{vmatrix} \text{ by using property}$$

$$= 100 \times 0 \text{ (} R_1 \text{ and } R_3 \text{ are identical)}$$

$$= 0$$

ii)  $\begin{vmatrix} 312 & 313 & 314 \\ 315 & 316 & 317 \\ 318 & 319 & 320 \end{vmatrix} = 0$

$$\text{L.H.S.} = \begin{vmatrix} 312 & 313 & 314 \\ 315 & 316 & 317 \\ 318 & 319 & 320 \end{vmatrix}$$

$$C_2 \rightarrow C_2 - C_1$$

$$= \begin{vmatrix} 312 & 1 & 314 \\ 315 & 1 & 317 \\ 318 & 1 & 320 \end{vmatrix}$$

$$C_3 \rightarrow C_3 - C_1$$

$$= \begin{vmatrix} 312 & 1 & 2 \\ 315 & 1 & 2 \\ 318 & 1 & 2 \end{vmatrix}$$

take 2 common from  $C_3$

$$= 2 \begin{vmatrix} 312 & 1 & 1 \\ 315 & 1 & 1 \\ 318 & 1 & 1 \end{vmatrix}$$

$$= 2(0) \quad (C_2 \text{ and } C_3 \text{ are identical)}$$

**Ex. 2)** Prove that  $\begin{vmatrix} 1 & a & bc \\ 1 & b & ca \\ 1 & c & ab \end{vmatrix} = \begin{vmatrix} 1 & a & a^2 \\ 1 & b & b^2 \\ 1 & c & c^2 \end{vmatrix}$

$$\text{L.H.S.} = \begin{vmatrix} 1 & a & bc \\ 1 & b & ca \\ 1 & c & ab \end{vmatrix}$$

$$R_1 \rightarrow aR_1$$

$$= \frac{1}{a} \begin{vmatrix} a & a^2 & abc \\ 1 & b & ca \\ 1 & c & ab \end{vmatrix}$$

$$R_2 \rightarrow bR_2$$

$$= \frac{1}{a} \times \frac{1}{b} \begin{vmatrix} a & a^2 & abc \\ b & b^2 & abc \\ 1 & c & ab \end{vmatrix}$$

$$R_3 \rightarrow cR_3$$

$$= \frac{1}{a} \times \frac{1}{b} \times \frac{1}{c} \begin{vmatrix} a & a^2 & abc \\ b & b^2 & abc \\ c & c^2 & abc \end{vmatrix}$$

$$= \frac{1}{abc} \times abc \begin{vmatrix} a & a^2 & 1 \\ b & b^2 & 1 \\ c & c^2 & 1 \end{vmatrix}$$

(taking abc common from  $C_3$ )

$$= \begin{vmatrix} a & a^2 & 1 \\ b & b^2 & 1 \\ c & c^2 & 1 \end{vmatrix}$$

$$C_1 \leftrightarrow C_3$$

$$= (-1) \begin{vmatrix} 1 & a^2 & a \\ 1 & b^2 & b \\ 1 & c^2 & c \end{vmatrix}$$

$$C_2 \leftrightarrow C_3$$

$$= (-1)(-1) \begin{vmatrix} 1 & a & a^2 \\ 1 & b & b^2 \\ 1 & c & c^2 \end{vmatrix}$$

$$= \begin{vmatrix} 1 & a & a^2 \\ 1 & b & b^2 \\ 1 & c & c^2 \end{vmatrix} = \text{R.H.S.}$$

**Ex. 3)** If  $\begin{vmatrix} x & y & z \\ -x & y & z \\ x & -y & z \end{vmatrix} = k.xyz$  then find the value of k

**Solution :**

$$\text{L.H.S.} = \begin{vmatrix} x & y & z \\ -x & y & z \\ x & -y & z \end{vmatrix}$$

$$R_2 \rightarrow R_2 + R_1$$

$$= \begin{vmatrix} x & y & z \\ 0 & 2y & 2z \\ x & -y & z \end{vmatrix}$$

$$R_3 \rightarrow R_3 + R_1$$

$$= \begin{vmatrix} x & y & z \\ 0 & 2y & 2z \\ 2x & 0 & 2z \end{vmatrix}$$

$$= 2 \times 2 \begin{vmatrix} x & y & z \\ 0 & y & z \\ x & 0 & z \end{vmatrix} \text{ taking (2 common}$$

from  $R_2$  and  $R_3$ )

$$= 4[x(yz) - y(0 - xz) + z(0 - xy)]$$

$$= 4[xyz + xyz - xyz]$$

$$= 4xyz$$

From given condition

$$\text{L.H.S.} = \text{R.H.S.}$$

$$4xyz = kxyz$$

$$\therefore k = 4$$

### EXERCISE 4.2

Q.1) Without expanding evaluate the following determinants.

$$\text{i) } \begin{vmatrix} 1 & a & b+c \\ 1 & b & c+a \\ 1 & c & a+b \end{vmatrix} \quad \text{ii) } \begin{vmatrix} 2 & 3 & 4 \\ 5 & 6 & 8 \\ 6x & 9x & 12x \end{vmatrix} \quad \text{iii) } \begin{vmatrix} 2 & 7 & 65 \\ 3 & 8 & 75 \\ 5 & 9 & 86 \end{vmatrix}$$

Q.2) Prove that 
$$\begin{vmatrix} x+y & y+z & z+x \\ z+x & x+y & y+z \\ y+z & z+x & x+y \end{vmatrix} = 2 \begin{vmatrix} x & y & z \\ z & x & y \\ y & z & x \end{vmatrix}$$

Q.3) Using properties of determinant show that

i) 
$$\begin{vmatrix} a+b & a & b \\ a & a+c & c \\ b & c & b+c \end{vmatrix} = 4abc$$

ii) 
$$\begin{vmatrix} 1 & \log_x y & \log_x z \\ \log_y x & 1 & \log_y z \\ \log_z x & \log_z y & 1 \end{vmatrix} = 0$$

Q.5) Solve the following equations.

i) 
$$\begin{vmatrix} x+2 & x+6 & x-1 \\ x+6 & x-1 & x+2 \\ x-1 & x+2 & x+6 \end{vmatrix} = 0$$

ii) 
$$\begin{vmatrix} x-1 & x & x-2 \\ 0 & x-2 & x-3 \\ 0 & 0 & x-3 \end{vmatrix} = 0$$

Q.6) If 
$$\begin{vmatrix} 4+x & 4-x & 4-x \\ 4-x & 4+x & 4-x \\ 4-x & 4-x & 4+x \end{vmatrix} = 0$$
 then find the values of  $x$

Q.7) Without expanding determinants show that

$$\begin{vmatrix} 1 & 3 & 6 \\ 6 & 1 & 4 \\ 3 & 7 & 12 \end{vmatrix} + 4 \begin{vmatrix} 2 & 3 & 3 \\ 2 & 1 & 2 \\ 1 & 7 & 6 \end{vmatrix} = 10 \begin{vmatrix} 1 & 2 & 1 \\ 3 & 1 & 7 \\ 3 & 2 & 6 \end{vmatrix}$$

## 4.3 APPLICATIONS OF DETERMINANTS

### 4.3.1 Cramer's Rule

In linear algebra Cramer's rule is an explicit formula for the solution of a system of linear equations in many variables. In previous class we studied this with two variables. Our goal here is to expand the application of Cramer's rule to three equations in three variables (unknowns). Variables are usually denoted by  $x, y$  and  $z$ .

**Theorem** - Consider the following three linear equations in variables three  $x, y, z$ .

$$a_1x + b_1y + c_1z = d_1$$

$$a_2x + b_2y + c_2z = d_2$$

$$a_3x + b_3y + c_3z = d_3$$

Here  $a_i, b_i, c_i$  and  $d_i$  are constants.

The solution of this system of equations is

$$x = \frac{D_x}{D}, y = \frac{D_y}{D}, z = \frac{D_z}{D}$$

provided  $D \neq 0$  where

$$D = \begin{vmatrix} a_1 & b_1 & c_1 \\ a_2 & b_2 & c_2 \\ a_3 & b_3 & c_3 \end{vmatrix} \quad D_x = \begin{vmatrix} d_1 & b_1 & c_1 \\ d_2 & b_2 & c_2 \\ d_3 & b_3 & c_3 \end{vmatrix}$$

$$D_y = \begin{vmatrix} a_1 & d_1 & c_1 \\ a_2 & d_2 & c_2 \\ a_3 & d_3 & c_3 \end{vmatrix} \quad D_z = \begin{vmatrix} a_1 & b_1 & d_1 \\ a_2 & b_2 & d_2 \\ a_3 & b_3 & d_3 \end{vmatrix}$$

**Remark :**

- 1) You will find the proof of the Cramer's Rule in QR code.
- 2) If  $D = 0$  then there is no unique solution for the given system of equations.

**SOLVED EXAMPLES**

**Ex. 1)** Solve the following equation by using Cramer's rule.

$$x+y+z = 6, \quad x-y+z = 2, \quad x+2y-z = 2$$

**Solution :** Given equations are

$$x+y+z = 6 \quad x-y+z = 2 \quad x+2y-z = 2$$

$$\begin{aligned} D &= \begin{vmatrix} 1 & 1 & 1 \\ 1 & -1 & 1 \\ 1 & 2 & -1 \end{vmatrix} \\ &= 1(1-2) - 1(-1-1) + 1(2+1) \\ &= -1 + 2 + 3 \\ &= -1 + 5 \\ &= 4 \end{aligned}$$

$$\begin{aligned} Dx &= \begin{vmatrix} 6 & 1 & 1 \\ 2 & -1 & 1 \\ 2 & 2 & -1 \end{vmatrix} \\ &= 6(1-2) - 1(-2-2) + 1(4+2) \\ &= -6 + 4 + 6 \\ &= 4 \end{aligned}$$

$$\begin{aligned} Dy &= \begin{vmatrix} 1 & 6 & 1 \\ 1 & 2 & 1 \\ 1 & 2 & -1 \end{vmatrix} \\ &= 1(-2-2) - 6(-1-1) + 1(2-2) \\ &= -4 + 12 + 0 \\ &= 8 \end{aligned}$$

$$\begin{aligned} Dz &= \begin{vmatrix} 1 & 1 & 6 \\ 1 & -1 & 2 \\ 1 & 2 & 2 \end{vmatrix} \\ &= 1(-2-4) - 1(2-2) + 6(2+1) \\ &= -6 + 0 + 18 \\ &= 12 \end{aligned}$$

$$\therefore x = \frac{Dx}{D} = \frac{4}{4} = 1, \quad y = \frac{Dy}{D} = \frac{8}{4} = 2 \text{ and } z = \frac{Dz}{D} =$$

$\frac{12}{4} = 3$  are solutions of given equation.

**Ex. 2)** By using Cramer's rule solve the following linear equations.

$$x+y-z = 1, \quad 8x+3y-6z = 1, \quad -4x-y+3z = 1$$

**Solution :** Given equations are

$$\begin{aligned} x+y-z &= 1 \\ 8x+3y-6z &= 1 \\ -4x-y+3z &= 1 \end{aligned}$$

$$\begin{aligned} D &= \begin{vmatrix} 1 & 1 & -1 \\ 8 & 3 & -6 \\ -4 & 1 & 3 \end{vmatrix} \\ &= 1(9-6) - 1(24-24) - 1(-8+12) \\ &= 3 + 0 - 4 \\ &= -1 \end{aligned}$$

$$\begin{aligned} Dx &= \begin{vmatrix} 1 & 1 & -1 \\ 1 & 3 & -6 \\ 1 & -1 & 3 \end{vmatrix} \\ &= 1(9-6) - 1(3+6) - 1(-1-3) \\ &= 3 - 9 + 4 \\ &= -2 \end{aligned}$$

$$\begin{aligned} Dy &= \begin{vmatrix} 1 & 1 & -1 \\ 8 & 3 & -6 \\ -4 & 1 & 3 \end{vmatrix} \\ &= 1(3+6) - 1(24-24) - 1(8+4) \\ &= 9 - 0 - 12 \\ &= -3 \end{aligned}$$

$$\begin{aligned} Dz &= \begin{vmatrix} 1 & 1 & 1 \\ 8 & 3 & 1 \\ -4 & -1 & 1 \end{vmatrix} \\ &= 1(3+1) - 1(8+4) + 1(-8+12) \\ &= 4 - 12 + 4 \\ &= 8 - 12 \\ &= -4 \end{aligned}$$

$$\therefore x = \frac{Dx}{D} = \frac{-2}{-1} = 2, \quad y = \frac{Dy}{D} = \frac{-3}{-1} = 3 \text{ and}$$

$$\therefore z = \frac{Dz}{D} = \frac{-4}{-1} = 4$$

$\therefore x=2, y=3, z=4$  are the solutions of the given equations.

**Ex. 3)** Solve the following equations by using determinant

$$\frac{1}{x} + \frac{1}{y} + \frac{1}{z} = -2, \quad \frac{1}{x} - \frac{2}{y} + \frac{1}{z} = 3, \quad \frac{2}{x} - \frac{1}{y} + \frac{3}{z} = -1$$

**Solution :**

Put  $\frac{1}{x} = p$     $\frac{1}{y} = q$     $\frac{1}{z} = r$

∴ Equations are

$$p + q + r = -2$$

$$p - 2q + r = 3$$

$$2p - q + 3r = -1$$

$$\begin{aligned} D &= \begin{vmatrix} 1 & 1 & 1 \\ 1 & -2 & 1 \\ 2 & -1 & 3 \end{vmatrix} \\ &= 1(-6+1) - 1(3-2) + 1(-1+4) \\ &= -5 - 1 + 3 \\ &= -3 \end{aligned}$$

$$\begin{aligned} D_p &= \begin{vmatrix} -2 & 1 & 1 \\ 3 & -2 & 1 \\ -1 & -1 & 3 \end{vmatrix} \\ &= -2(-6+1) - 1(9+1) + 1(-3-2) \\ &= 10 - 10 - 5 \\ &= -5 \end{aligned}$$

$$\begin{aligned} D_q &= \begin{vmatrix} 1 & -2 & 1 \\ 1 & 3 & 1 \\ 2 & -1 & 3 \end{vmatrix} \\ &= 1(9+1) + 2(3-2) + 1(-1-6) \\ &= 10 + 2 - 7 \\ &= 5 \end{aligned}$$

$$\begin{aligned} D_r &= \begin{vmatrix} 1 & 1 & -2 \\ 1 & -2 & 3 \\ 2 & -1 & -1 \end{vmatrix} \\ &= 1(2+3) - 1(-1-6) - 2(-1+4) \\ &= 5 + 7 - 6 \\ &= 6 \end{aligned}$$

$$\therefore p = \frac{D_p}{D} = \frac{-5}{-3} = \frac{5}{3},$$

$$q = \frac{D_q}{D} = \frac{5}{-3} = -\frac{5}{3},$$

$$r = \frac{D_r}{D} = \frac{6}{-3} = -2$$

$$\therefore \frac{1}{x} = p = \frac{5}{3} \quad \therefore x = \frac{3}{5},$$

$$\therefore \frac{1}{y} = q = -\frac{5}{3} \quad \therefore y = -\frac{3}{5},$$

$$\therefore \frac{1}{z} = r = -2 \quad \therefore z = -\frac{1}{2}$$

∴  $x = \frac{3}{5}$ ,  $y = -\frac{3}{5}$ ,  $z = -\frac{1}{2}$  are the solutions of the equations.

**Ex. 4)** The cost of 2 books, 6 notebooks and 3 pens is Rs.120. The cost of 3 books, 4 notebooks and 2 pens is Rs.105. while the cost of 5 books, 7 notebooks and 4 pens is Rs.183. Using this information find the cost of 1 book, 1 notebook and 1 pen.

**Solution :** Let Rs.  $x$ , Rs.  $y$  and Rs.  $z$  be the cost of one book, one notebook and one pen respectively. Then by given information we have,

$$2x + 6y + 3z = 120$$

$$3x + 4y + 2z = 105$$

$$5x + 7y + 4z = 183$$

$$\begin{aligned} D &= \begin{vmatrix} 2 & 6 & 3 \\ 3 & 4 & 2 \\ 5 & 7 & 4 \end{vmatrix} \\ &= 2(16-14) - 6(12-10) + 3(21-20) \\ &= 2(2) - 6(2) + 3(1) \\ &= 4 - 12 + 3 \\ &= 7 - 12 \\ &= -5 \end{aligned}$$

$$\begin{aligned}
 Dx &= \begin{vmatrix} 120 & 6 & 3 \\ 105 & 4 & 2 \\ 183 & 7 & 4 \end{vmatrix} = 3 \begin{vmatrix} 40 & 6 & 3 \\ 35 & 4 & 2 \\ 61 & 7 & 4 \end{vmatrix} \\
 &= 3 [40(16-14) - 6(140-122) + 3(245-244)] \\
 &= 3[40(2) - 6(18) + 3(1)] \\
 &= 3[80 - 108 + 3] \\
 &= 3[83 - 108] \\
 &= 3[-25] = -75
 \end{aligned}$$

$$\begin{aligned}
 Dy &= \begin{vmatrix} 2 & 120 & 3 \\ 3 & 105 & 2 \\ 5 & 183 & 4 \end{vmatrix} = 3 \begin{vmatrix} 2 & 40 & 3 \\ 3 & 35 & 2 \\ 5 & 61 & 4 \end{vmatrix} \\
 &= 3[2(140-122) - 40(12-10) + 3(183-175)] \\
 &= 3[2(18) - 40(2) + 3(8)] \\
 &= 3[36 - 80 + 24] \\
 &= 3[60 - 80] \\
 &= 3[-20] \\
 &= -60
 \end{aligned}$$

$$\begin{aligned}
 Dz &= \begin{vmatrix} 2 & 6 & 40 \\ 3 & 4 & 35 \\ 5 & 7 & 61 \end{vmatrix} = 3 \begin{vmatrix} 2 & 6 & 120 \\ 3 & 4 & 105 \\ 5 & 7 & 183 \end{vmatrix} \\
 &= 3[2(244-245) - 6(183-175) + 40(21-20)] \\
 &= 3[2(-1) - 6(8) + 40(1)] \\
 &= 3[-2 - 48 + 40] \\
 &= 3[-50 + 40] \\
 &= 3[-10] \\
 &= -30
 \end{aligned}$$

$$\therefore x = \frac{Dx}{D} = \frac{-75}{-5} = 15, y = \frac{Dy}{D} = \frac{-60}{-5} = 12,$$

$$z = \frac{Dz}{D} = \frac{-30}{-5} = 6$$

$\therefore$  Rs. 15, Rs. 12, Rs. 6 are the costs of one book, one notebook and one pen respectively.

### 4.3.2 Consistency of three equations in two variables

Consider the system of three linear equations in two variables  $x$  and  $y$

$$\left. \begin{aligned}
 a_1x + b_1y + c_1 &= 0 & \text{(I)} \\
 a_2x + b_2y + c_2 &= 0 & \text{(II)} \\
 a_3x + b_3y + c_3 &= 0 & \text{(III)}
 \end{aligned} \right\}$$

These three equations are said to be consistent if they have a common solution.

**Theorem :** The necessary condition for the equation  $a_1x + b_1y + c_1 = 0$ ,  $a_2x + b_2y + c_2 = 0$ ,  $a_3x + b_3y + c_3 = 0$  to be consistent is

$$\begin{vmatrix} a_1 & b_1 & c_1 \\ a_2 & b_2 & c_2 \\ a_3 & b_3 & c_3 \end{vmatrix} = 0$$

**Proof :** Consider the system of three linear equations in two variables  $x$  and  $y$ .

$$\left. \begin{aligned}
 a_1x + b_1y + c_1 &= 0 \\
 a_2x + b_2y + c_2 &= 0 \\
 a_3x + b_3y + c_3 &= 0
 \end{aligned} \right\} \text{(I)}$$

We shall now obtain the necessary condition for the system (I) be consistent.

Consider the solution of the equations

$$\begin{aligned}
 a_2x + b_2y &= -c_2 \\
 a_3x + b_3y &= -c_3
 \end{aligned}$$

If  $\begin{vmatrix} a_2 & b_2 \\ a_3 & b_3 \end{vmatrix} \neq 0$  then by Cramer's Rule the system

of two unknowns, we have

$$x = \frac{\begin{vmatrix} -c_2 & b_2 \\ -c_3 & b_3 \end{vmatrix}}{\begin{vmatrix} a_2 & b_2 \\ a_3 & b_3 \end{vmatrix}}, \quad y = \frac{\begin{vmatrix} a_2 & -c_2 \\ a_3 & -c_3 \end{vmatrix}}{\begin{vmatrix} a_2 & b_2 \\ a_3 & b_3 \end{vmatrix}} \text{ put these}$$

values in equation  $a_1x + b_1y + c_1 = 0$  then

$$a_1 \begin{vmatrix} -c_2 & b_2 \\ -c_3 & b_3 \\ a_2 & b_2 \\ a_3 & b_3 \end{vmatrix} + b_1 \begin{vmatrix} a_2 & -c_2 \\ a_3 & -c_3 \\ a_2 & b_2 \\ a_3 & b_3 \end{vmatrix} + c_1 = 0$$

$$\text{i.e. } a_1 \begin{vmatrix} -c_2 & b_2 \\ -c_3 & b_3 \\ a_2 & b_2 \\ a_3 & b_3 \end{vmatrix} + b_1 \begin{vmatrix} a_2 & -c_2 \\ a_3 & -c_3 \\ a_2 & b_2 \\ a_3 & b_3 \end{vmatrix} + c_1 \begin{vmatrix} a_2 & b_2 \\ a_3 & b_3 \end{vmatrix} = 0$$

$$\text{i.e. } -a_1 \begin{vmatrix} c_2 & b_2 \\ c_3 & b_3 \\ a_2 & c_2 \\ a_3 & c_3 \end{vmatrix} - b_1 \begin{vmatrix} a_2 & c_2 \\ a_3 & c_3 \\ a_2 & b_2 \\ a_3 & b_3 \end{vmatrix} + c_1 \begin{vmatrix} a_2 & b_2 \\ a_3 & b_3 \end{vmatrix} = 0$$

$$\text{i.e. } a_1 \begin{vmatrix} b_2 & c_2 \\ b_3 & c_3 \\ a_2 & c_2 \\ a_3 & c_3 \end{vmatrix} - b_1 \begin{vmatrix} a_2 & c_2 \\ a_3 & c_3 \\ a_2 & b_2 \\ a_3 & b_3 \end{vmatrix} + c_1 \begin{vmatrix} a_2 & b_2 \\ a_3 & b_3 \end{vmatrix} = 0$$

$$\text{i.e. } \begin{vmatrix} a_1 & b_1 & c_1 \\ a_2 & b_2 & c_2 \\ a_3 & b_3 & c_3 \end{vmatrix} = 0$$

**Note :** This is a necessary condition that the equations are consistent. The above condition of consistency in general is not sufficient.

### SOLVED EXAMPLES

**Ex. 1)** Verify the consistency of following equations

$$2x+2y = -2, x + y = -1, 3x + 3y = -5$$

**Solution :** By condition of consistency consider

$$\begin{vmatrix} a_1 & b_1 & c_1 \\ a_2 & b_2 & c_2 \\ a_3 & b_3 & c_3 \end{vmatrix} = \begin{vmatrix} 2 & 2 & 2 \\ 1 & 1 & 1 \\ 3 & 3 & 5 \end{vmatrix}$$

$$= 2(5-3) - 2(5-3) + 2(3-3) = 4 - 4 + 0 = 0$$

But the equations have no common Solution. (why?)

**Ex. 2)** Examine the consistency of following equations.

$$\text{i) } x + y = 2, 2x + 3y = 5, 3x - 2y = 1$$

**Solution :** Write the given equation in standard form.

$$x + y - 2 = 0, 2x + 3y - 5 = 0, 3x - 2y - 1 = 0$$

$$\begin{vmatrix} a_1 & b_1 & c_1 \\ a_2 & b_2 & c_2 \\ a_3 & b_3 & c_3 \end{vmatrix} = \begin{vmatrix} 1 & 1 & -2 \\ 2 & 3 & -5 \\ 3 & -2 & -1 \end{vmatrix}$$

$$= 1(-3-10) - 1(-2+15) - 2(-4-9)$$

$$= -13 - 13 + 26 = 0$$

∴ Given equations are consistent.

$$\text{ii) } x + 2y - 3 = 0, 7x + 4y - 11 = 0, 2x + 3y + 1 = 0$$

$$\begin{vmatrix} a_1 & b_1 & c_1 \\ a_2 & b_2 & c_2 \\ a_3 & b_3 & c_3 \end{vmatrix} = \begin{vmatrix} 1 & 2 & -3 \\ 7 & 4 & -11 \\ 2 & 3 & 1 \end{vmatrix}$$

$$= 1(4+33) - 2(7+22) - 3(21-8)$$

$$= 37 - 58 - 39 = 37 - 97$$

$$= -60 \neq 0$$

∴ Given system of equations is not consistent.

$$\text{iii) } x + y = 1, 2x + 2y = 2, 3x + 3y = 5$$

**Solution :**  $x + y = 1, 2x + 2y = 2, 3x + 3y = 5$  are given equations.

Check the condition of consistency.

$$\begin{vmatrix} 1 & 1 & -1 \\ 2 & 2 & -2 \\ 3 & 3 & -5 \end{vmatrix} = 2 \begin{vmatrix} 1 & 1 & -1 \\ 1 & 1 & -1 \\ 3 & 3 & -5 \end{vmatrix}$$

$$= 2(0) = 0 \quad (R_1 \text{ and } R_2 \text{ are identical})$$

Let us examine further.

Note that lines given by the equations  $x + y = 1$  and  $3x + 3y = 5$  are parallel to each other. They do not have a common solution, so equations are not consistent.

**Ex. 3)** Find the value of k if the following equations are consistent.

$$7x - ky = 4, 2x + 5y = 9 \text{ and } 2x + y = 8$$

**Solution :** Given equations are

$$7x - ky - 4 = 0, 2x + 5y - 9 = 0,$$

$2x + y - 8 = 0$  are consistent

$$\therefore \begin{vmatrix} 7 & -k & 4 \\ 2 & 5 & -9 \\ 2 & 1 & -8 \end{vmatrix} = 0$$

$$\therefore 7(-40+9) + k(-16+18) - 4(2-10) = 0$$

$$\therefore 7(-31) + 2k - 4(-8) = 0$$

$$\therefore -217 + 2k + 32 = 0 \quad -185 + 2k = 0$$

$$\therefore 2k = 185 \quad \therefore k = \frac{185}{2}$$

### 4.3.3 Area of triangle and Collinearity of three points.

**Theorem :** If  $A(x_1, y_1)$ ,  $B(x_2, y_2)$  and  $C(x_3, y_3)$  are vertices of triangle ABC then the area of triangle is

$$\frac{1}{2} \begin{vmatrix} x_1 & y_1 & 1 \\ x_2 & y_2 & 1 \\ x_3 & y_3 & 1 \end{vmatrix}$$

**Proof :** Consider a triangle ABC in Cartesian coordinate system. Draw AP, CQ and BR perpendicular to the X axis

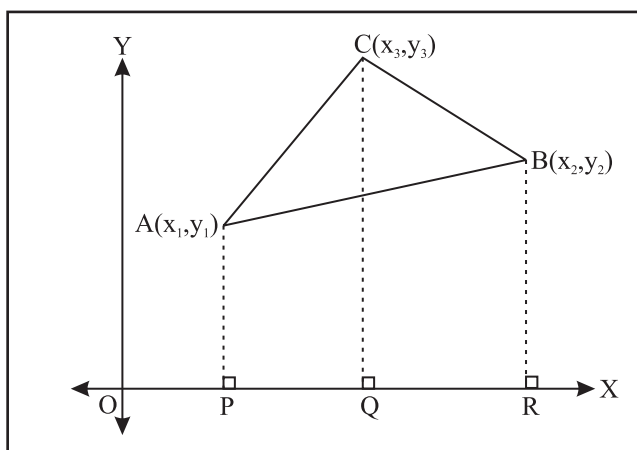

Fig. 4.1

From the figure,

Area of  $\triangle ABC$  = Area of trapezium PACQ + Area of trapezium QCBR – Area of trapezium PABR

$$\begin{aligned} \text{Area of triangle ABC} &= \frac{1}{2} \text{PQ} \cdot [\text{AP} + \text{CQ}] \\ &+ \frac{1}{2} \text{QR} \cdot [\text{QC} + \text{BR}] - \frac{1}{2} \text{PR} \cdot [\text{AP} + \text{BR}] \\ &= \frac{1}{2} (y_1 + y_3) (x_3 - x_1) + \frac{1}{2} (y_2 + y_3) (x_2 - x_3) \\ &- \frac{1}{2} (y_1 + y_2) (x_2 - x_1) \\ &= \frac{1}{2} [y_1 x_3 - x_1 y_1 + x_3 y_3 - x_1 y_3 + x_2 y_2 - x_3 y_2 + x_2 y_3 \\ &- x_3 y_3 - x_2 y_1 + x_1 y_1 - x_2 y_2 + x_1 y_2] \\ &= \frac{1}{2} [y_1 x_3 - x_1 y_3 - x_3 y_2 + x_2 y_3 - x_2 y_1 + x_1 y_2] \\ &= \frac{1}{2} [x_1 (y_2 - y_3) - x_2 (y_1 - y_3) + x_3 (y_1 - y_2)] \\ &= \frac{1}{2} \begin{vmatrix} x_1 & x_2 & x_3 \\ y_1 & y_2 & y_3 \\ 1 & 1 & 1 \end{vmatrix} = \frac{1}{2} \begin{vmatrix} x_1 & y_1 & 1 \\ x_2 & y_2 & 1 \\ x_3 & y_3 & 1 \end{vmatrix} \end{aligned}$$

#### Remark:

i) Area is a positive quantity. Hence we always take the absolute value of a determinant.

ii) If area is given, consider both positive and negative values of the determinant for calculation of unknown co-ordinates.

iii) If area of a triangle is zero then the given three points are **collinear**.

#### SOLVED EXAMPLES

**Ex. 1)** Find the area of the triangle whose vertices are  $A(-2, -3)$ ,  $B(3, 2)$  and  $C(-1, -8)$

**Solution :** Given  $(x_1, y_1) = (-2, -3)$ ,  $(x_2, y_2) = (3, 2)$ , and  $(x_3, y_3) = (-1, -8)$

We know that area of triangle

$$= \frac{1}{2} \begin{vmatrix} x_1 & y_1 & 1 \\ x_2 & y_2 & 1 \\ x_3 & y_3 & 1 \end{vmatrix} = \frac{1}{2} \begin{vmatrix} -2 & -3 & 1 \\ 3 & 2 & 1 \\ -1 & -8 & 1 \end{vmatrix}$$

$$\begin{aligned}
 &= \frac{1}{2} [-2(2+8)+3(3+1)+1(-24+2)] \\
 &= \frac{1}{2} [-20+12-22] \\
 &= \frac{1}{2} [-42+12] = \frac{1}{2} [-30] = -15
 \end{aligned}$$

Area is positive.

∴ Area of triangle = 15 square unit

This gives the area of the triangle ABC in that order of the vertices. If we consider the same triangle as ACB, then triangle is considered in opposite orientation. The area then is 15 sq. units. This also agrees with the rule that interchanging 2<sup>nd</sup> and 3<sup>rd</sup> rows changes the sign of the determinant.

**Ex. 2)** If the area of triangle with vertices P(-3, 0), Q(3, 0) and R(0, K) is 9 square unit then find the value of k.

**Solution :** Given  $(x_1, y_1) \equiv (-3, 0)$ ,  $(x_2, y_2) \equiv (3, 0)$  and  $(x_3, y_3) \equiv (0, k)$  and area of  $\Delta$  is 9 sq. unit.

We know that area of  $\Delta = \frac{1}{2} \begin{vmatrix} x_1 & y_1 & 1 \\ x_2 & y_2 & 1 \\ x_3 & y_3 & 1 \end{vmatrix}$

$$\therefore \pm 9 = \frac{1}{2} \begin{vmatrix} -3 & 0 & 1 \\ 3 & 0 & 1 \\ 0 & k & 1 \end{vmatrix} \quad (\text{Area is positive but the}$$

determinant can be of either sign)

$$\therefore \pm 9 = \frac{1}{2} [-3(0 - k) + 1(3k - 0)]$$

$$\therefore \pm 9 = \frac{1}{2} [3 \times 3k] \quad \therefore \pm 9 = 3k \quad \therefore k = \pm 3$$

**Ex. 3)** Find the area of triangle whose vertices are A(3, 7) B(4, -3) and C(5, -13). Interpret your answer.

**Solution :** Given  $(x_1, y_1) \equiv (3, 7)$ ,  $(x_2, y_2) \equiv (4, -3)$  and  $(x_3, y_3) \equiv (5, -13)$

$$\begin{aligned}
 \text{Area of } \Delta &= \frac{1}{2} \begin{vmatrix} x_1 & y_1 & 1 \\ x_2 & y_2 & 1 \\ x_3 & y_3 & 1 \end{vmatrix} = \frac{1}{2} \begin{vmatrix} 3 & 7 & 1 \\ 4 & -3 & 1 \\ 5 & -13 & 1 \end{vmatrix} \\
 &= \frac{1}{2} [3(-3+13) - 7(4-5) + 1(-52+15)]
 \end{aligned}$$

$$= \frac{1}{2} [30+7-37] = \frac{1}{2} [37-37] = 0$$

$A(\Delta ABC) = 0$  ∴ A, B, C are collinear points

**Ex. 4)** Show that the following points are collinear by determinant method.

A(2, 5), B(5, 7), C(8, 9)

**Solution :** Given A  $\equiv (x_1, y_1) = (2, 5)$ , B  $\equiv (x_2, y_2) \equiv (5, 7)$ , C  $\equiv (x_3, y_3) \equiv (8, 9)$

If  $\begin{vmatrix} x_1 & y_1 & 1 \\ x_2 & y_2 & 1 \\ x_3 & y_3 & 1 \end{vmatrix} = 0$  then, A, B, C are collinear

$$\therefore \begin{vmatrix} 2 & 5 & 1 \\ 5 & 7 & 1 \\ 8 & 9 & 1 \end{vmatrix} = 2(7-9) - 5(5-8) + 1(45-56)$$

$$= -4 + 15 - 11 = -15 + 15 = 0$$

∴ A, B, C are collinear.

### EXERCISE 4.3

**Q.1)** Solve the following linear equations by using Cramer's Rule.

i)  $x+y+z = 6$ ,  $x-y+z = 2$ ,  $x+2y-z = 2$

ii)  $x+y-2z = -10$ ,  
 $2x+y-3z = -1$ ,  $4x+6y+z = 2$

iii)  $x+z = 1$ ,  $y+z = 1$ ,  $x+y = 4$

$$\text{iv) } \frac{-2}{x} - \frac{1}{y} - \frac{3}{z} = 3, \quad \frac{2}{x} - \frac{3}{y} + \frac{1}{z} = -13$$

$$\text{and } \frac{2}{x} - \frac{3}{z} = -11$$

**Q.2)** The sum of three numbers is 15. If the second number is subtracted from the sum of first and third numbers then we get 5. When the third number is subtracted from the sum of twice the first number and the second number, we get 4. Find the three numbers.

**Q.3)** Examine the consistency of the following equations.

i)  $2x - y + 3 = 0, 3x + y - 2 = 0, 11x + 2y - 3 = 0$

ii)  $2x + 3y - 4 = 0, x + 2y = 3, 3x + 4y + 5 = 0$

iii)  $x + 2y - 3 = 0, 7x + 4y - 11 = 0, 2x + 4y - 6 = 0$

**Q.4)** Find k if the following equations are consistent.

i)  $2x + 3y - 2 = 0, 2x + 4y - k = 0, x - 2y + 3k = 0$

ii)  $kx + 3y + 1 = 0, x + 2y + 1 = 0, x + y = 0$

**Q.5)** Find the area of triangle whose vertices are

i) A(5,8), B(5,0) C(1,0)

ii) P( $\frac{3}{2}, 1$ ), Q(4, 2), R(4,  $\frac{-1}{2}$ )

iii) M(0, 5), N(-2, 3), T(1, -4)

**Q.6)** Find the area of quadrilateral whose vertices are

A(-3, 1), B(-2, -2), C(1, 4), D(3, -1)

**Q.7)** Find the value of k, if the area of triangle whose vertices are P(k, 0), Q(2, 2), R(4, 3) is  $\frac{3}{2}$  sq.unit

**Q.8)** Examine the collinearity of the following set of points

i) A(3, -1), B(0, -3), C(12, 5)

ii) P(3, -5), Q(6, 1), R(4, 2)

iii) L(0,  $\frac{1}{2}$ ), M(2, -1), N(-4,  $\frac{7}{2}$ )

### MISCELLANEOUS EXERCISE - 4 (A)

**(I) Select the correct option from the given alternatives.**

Q.1 The determinant  $D = \begin{vmatrix} a & b & a+b \\ b & c & b+c \\ a+b & b+c & 0 \end{vmatrix}$

= 0 If

A) a, b, c are in A.P.

B) a, b, c are in G.P.

C) a, b, c are in H.P.

D)  $\alpha$  is root of  $ax^2 + 2bx + c = 0$

Q.2 If  $\begin{vmatrix} x^k & x^{k+2} & x^{k+3} \\ y^k & y^{k+2} & y^{k+3} \\ z^k & z^{k+2} & z^{k+3} \end{vmatrix} = (x-y)(y-z)(z-x)$

$(\frac{1}{x} + \frac{1}{y} + \frac{1}{z})$  then

A)  $k = -3$  B)  $k = -1$  C)  $k = 1$  D)  $k = 3$

Q.3 Let  $D = \begin{vmatrix} \sin\theta \cdot \cos\phi & \sin\theta \cdot \sin\phi & \cos\theta \\ \cos\theta \cdot \cos\phi & \cos\theta \cdot \sin\phi & -\sin\theta \\ -\sin\theta \cdot \sin\phi & \sin\theta \cdot \cos\phi & 0 \end{vmatrix}$  then

A) D is independent of  $\theta$

B) D is independent of  $\phi$

C) D is a constant

D)  $\frac{dD}{d\theta}$  at  $\theta = \pi/2$  is equal to 0

Q.4 The value of a for which system of equation  $a^3x + (a + 1)^3y + (a + 2)^3z = 0$   $ax + (a + 1)y + (a + 2)z = 0$  and  $x + y + z = 0$  has non zero Soln. is

A) 0 B) -1 C) 1 D) 2

Q.5  $\begin{vmatrix} b+c & c+a & a+b \\ q+r & r+p & p+q \\ y+z & z+x & x+y \end{vmatrix} =$

- C) Determinant is number associated to square matrix  
d] None of these

A)  $2 \begin{vmatrix} c & b & a \\ r & q & p \\ z & y & x \end{vmatrix}$  B)  $2 \begin{vmatrix} b & a & c \\ q & p & r \\ y & x & z \end{vmatrix}$  C)  $2 \begin{vmatrix} a & b & c \\ p & q & r \\ x & y & z \end{vmatrix}$

**(II) Answer the following questions.**

D)  $2 \begin{vmatrix} a & c & b \\ p & r & q \\ x & z & y \end{vmatrix}$

Q.1) Evaluate i)  $\begin{vmatrix} 2 & -5 & 7 \\ 5 & 2 & 1 \\ 9 & 0 & 2 \end{vmatrix}$  ii)  $\begin{vmatrix} 1 & -3 & 12 \\ 0 & 2 & -4 \\ 9 & 7 & 2 \end{vmatrix}$

Q.6 The system  $3x - y + 4z = 3$ ,  $x + 2y - 3z = -2$  and  $6x + 5y + \lambda z = -3$  has at least one Solution when

Q.2) Evaluate determinant along second column

- A)  $\lambda = -5$       B)  $\lambda = 5$   
C)  $\lambda = 3$       D)  $\lambda = -13$

$$\begin{vmatrix} 1 & -1 & 2 \\ 3 & 2 & -2 \\ 0 & 1 & -2 \end{vmatrix}$$

Q.3) Evaluate i)  $\begin{vmatrix} 2 & 3 & 5 \\ 400 & 600 & 1000 \\ 48 & 47 & 18 \end{vmatrix}$

Q.7 If  $x = -9$  is a root of  $\begin{vmatrix} x & 3 & 7 \\ 2 & x & 2 \\ 7 & 6 & x \end{vmatrix} = 0$  has

ii)  $\begin{vmatrix} 101 & 102 & 103 \\ 106 & 107 & 108 \\ 1 & 2 & 3 \end{vmatrix}$  by using properties

other two roots are

- A) 2, -7    B) -2, 7    C) 2, 7    D) -2, -7

Q.4) Find minor and cofactor of elements of the determinant.

Q.8 If  $\begin{vmatrix} 6i & -3i & 1 \\ 4 & 3i & -1 \\ 20 & 3 & i \end{vmatrix} = x + iy$  then

i)  $\begin{vmatrix} -1 & 0 & 4 \\ -2 & 1 & 3 \\ 0 & -4 & 2 \end{vmatrix}$  ii)  $\begin{vmatrix} 1 & -1 & 2 \\ 3 & 0 & -2 \\ 1 & 0 & 3 \end{vmatrix}$

- A)  $x = 3, y = 1$     B)  $x = 1, y = 3$   
C)  $x = 0, y = 3$     D)  $x = 0, y = 0$

Q.5) Find the value of x if

Q.9 If A(0,0), B(1,3) and C(k,0) are vertices of triangle ABC whose area is 3 sq.units then value of k is

i)  $\begin{vmatrix} 1 & 4 & 20 \\ 1 & -2 & -5 \\ 1 & 2x & 5x^2 \end{vmatrix} = 0$  ii)  $\begin{vmatrix} 1 & 2x & 4x \\ 1 & 4 & 16 \\ 1 & 1 & 1 \end{vmatrix} = 0$

- A) 2    B) -3    C) 3 or -3    D) -2 or +2

Q.6) By using properties of determinant prove

Q.10 Which of the following is correct

that  $\begin{vmatrix} x+y & y+z & z+x \\ z & x & y \\ 1 & 1 & 1 \end{vmatrix} = 0$

- A) Determinant is square matrix  
B) Determinant is number associated to matrix

Q.7) Without expanding determinant show that

$$i) \begin{vmatrix} b+c & bc & b^2c^2 \\ c+a & ca & c^2a^2 \\ a+b & ab & a^2b^2 \end{vmatrix} = 0 \quad ii) \begin{vmatrix} xa & yb & zc \\ a^2 & b^2 & c^2 \\ 1 & 1 & 1 \end{vmatrix}$$

$$= \begin{vmatrix} x & y & z \\ a & b & c \\ bc & ca & ab \end{vmatrix}$$

$$iii) \begin{vmatrix} l & m & n \\ e & d & f \\ u & v & w \end{vmatrix} = \begin{vmatrix} n & f & w \\ l & e & u \\ m & d & v \end{vmatrix}$$

$$iv) \begin{vmatrix} 0 & a & b \\ -a & 0 & c \\ -b & -c & 0 \end{vmatrix} = 0$$

Q.8) If  $\begin{vmatrix} a & 1 & 1 \\ 1 & b & 1 \\ 1 & 1 & c \end{vmatrix} = 0$  then show that

$$\frac{1}{1-a} + \frac{1}{1-b} + \frac{1}{1-c} = 1$$

Q.9) Solve the following linear equations by Cramer's Rule.

i)  $2x - y + z = 1, x + 2y + 3z = 8, 3x + y - 4z = 1$

ii)  $\frac{1}{x} + \frac{1}{y} = \frac{3}{2}, \frac{1}{y} + \frac{1}{z} = \frac{5}{6}, \frac{1}{z} + \frac{1}{x} = \frac{4}{3}$

iii)  $2x + 3y + 3z = 5, x - 2y + z = -4, 3x - y - 2z = 3$

iv)  $x - y + 2z = 7, 3x + 4y - 5z = 5, 2x - y + 3z = 12$

Q.10) Find the value of k if the following equation are consistent.

i)  $(k+1)x + (k-1)y + (k-1)z = 0$

$(k-1)x + (k+1)y + (k-1)z = 0$

$(k-1)x + (k-1)y + (k+1)z = 0$

ii)  $3x + y - 2z = 0, kx + 2y - 3z = 0$  and  $2x - y = 3$

iii)  $(k-2)x + (k-1)y = 17,$

$(k-1)x + (k-2)y = 18$  and  $x + y = 5$

Q.11) Find the area of triangle whose vertices are

i) A(-1,2), B(2,4), C(0,0)

ii) P(3,6), Q(-1,3), R(2,-1)

iii) L(1,1), M(-2,2), N(5,4)

Q.12) Find the value of k

i) If area of triangle is 4 square unit and vertices are P(k, 0), Q(4, 0), R(0, 2)

ii) If area of triangle is  $33/2$  square unit and vertices are L(3,-5), M(-2,k), N(1,4)

Q.13) Find the area of quadrilateral whose vertices are A(0, -4), B(4, 0), C(-4, 0), D(0, 4)

Q.14) An amount of ₹ 5000 is put into three investments at the rate of interest of 6%, 7% and 8% per annum respectively. The total annual income is ₹ 350. If the combined income from the first two investments is ₹ 7000 more than the income from the third. Find the amount of each investment.

Q.15) Show that the lines  $x - y = 6, 4x - 3y = 20$  and  $6x + 5y + 8 = 0$  are concurrent. Also find the point of concurrence

Q.16) Show that the following points are collinear by determinant

a) L(2,5), M(5,7), N(8,9)

b) P(5,1), Q(1,-1), R(11,4)

### Further Use of Determinants

- 1) To find the volume of parallelepiped and tetrahedron by vector method
- 2) To state the condition for the equation  $ax^2 + 2hxy + by^2 + 2gx + 2fy + c = 0$  representing a pair of straight lines.
- 3) To find the shortest distance between two skew lines.
- 4) Test for intersection of two line in three dimensional geometry.

- 5) To find cross product of two vectors and scalar triple product of vectors
- 6) Formation of differential equation by eliminating arbitrary constant.



#### 4.4 Introduction to Matrices :

The theory of matrices was developed by a Mathematician Arthur Cayley. Matrices are useful in expressing numerical information in compact form. They are effectively used in expressing different operators. Hence in Economics, Statistics and Computer science they are essential.

**Definition :** A rectangular arrangement of  $mn$  numbers in  $m$  rows and  $n$  columns, enclosed in [ ] or ( ) is called a matrix of order  $m$  by  $n$ .

A matrix by itself does not have a value or any special meaning.

Order of the matrix is denoted by  $m \times n$ , read as  $m$  by  $n$ .

Each member of the matrix is called an element of the matrix.

Matrices are generally denoted by  $A, B, C, \dots$  and their elements are denoted by  $a_{ij}, b_{ij}, c_{ij}, \dots$  etc. e.g.  $a_{ij}$  is the element in  $i$ th row and  $j$ th column of the matrix.

For example, i)  $A = \begin{bmatrix} 2 & -3 & 9 \\ 1 & 0 & -7 \\ 4 & -2 & 1 \end{bmatrix}$  Here  $a_{32} = -2$

$A$  is a matrix having 3 rows and 3 columns. The order of  $A$  is  $3 \times 3$ , read as three by three. There are 9 elements in matrix  $A$ .

ii)  $B = \begin{bmatrix} -1 & -5 \\ 2 & 0 \\ 6 & 9 \end{bmatrix}$

$B$  is a matrix having 3 rows and 2 columns. The order of  $B$  is  $3 \times 2$ . There are 6 elements in matrix  $B$ .

iii)  $C = \begin{bmatrix} 1+i & 8 \\ i & -3i \end{bmatrix}$ ,  $C$  is a matrix of order  $2 \times 2$ .

iv)  $D = \begin{bmatrix} -1 & 9 & 2 \\ 3 & 0 & -3 \end{bmatrix}$ ,  $D$  is a matrix of order  $2 \times 3$ .

In general a matrix of order  $m \times n$  is represented by

$$A = [a_{ij}]_{m \times n} = \begin{bmatrix} a_{11} & a_{12} & \dots & a_{1j} & \dots & a_{1n} \\ a_{21} & a_{22} & \dots & a_{2j} & \dots & a_{2n} \\ a_{31} & a_{32} & \dots & a_{3j} & \dots & a_{3n} \\ \dots & \dots & \dots & \dots & \dots & \dots \\ a_{i1} & a_{i2} & \dots & a_{ij} & \dots & a_{in} \\ a_{m1} & a_{m2} & \dots & a_{mj} & \dots & a_{mn} \end{bmatrix}$$

Here  $a_{ij}$  = An element in  $i$ th row and  $j$ th column.

**Ex.** In matrix  $A = \begin{bmatrix} 2 & -3 & 9 \\ 1 & 0 & -7 \\ 4 & -2 & 1 \end{bmatrix} = \begin{bmatrix} a_{11} & a_{12} & a_{13} \\ a_{21} & a_{22} & a_{23} \\ a_{31} & a_{32} & a_{33} \end{bmatrix}$

$a_{11} = 2, a_{12} = -3, a_{13} = 9, a_{21} = 1, a_{22} = 0, a_{23} = -7, a_{31} = 4, a_{32} = -2, a_{33} = 1$

#### 4.4.1 Types of Matrices :

1) **Row Matrix :** A matrix having only one row is called as a row matrix. It is of order  $1 \times n$ , Where  $n \geq 1$ .

Ex. i)  $[-1 \ 2]_{1 \times 2}$  ii)  $[0 \ -3 \ 5]_{1 \times 3}$

2) **Column Matrix :** A matrix having only one column is called as a column matrix. It is of order  $m \times 1$ , Where  $m \geq 1$ .

**Ex.** i)  $\begin{bmatrix} 1 \\ 0 \end{bmatrix}_{2 \times 1}$  ii)  $\begin{bmatrix} 5 \\ -9 \\ -3 \end{bmatrix}_{3 \times 1}$

**Note :** Single element matrix is row matrix as well as column matrix. e.g.  $[5]_{1 \times 1}$

**3) Zero or Null matrix :** A matrix in which every element is zero is called as a zero or null matrix. It is denoted by O.

**Ex. i)**  $O = \begin{bmatrix} 0 & 0 & 0 \\ 0 & 0 & 0 \\ 0 & 0 & 0 \end{bmatrix}_{3 \times 3}$

**ii)**  $O = \begin{bmatrix} 0 & 0 \\ 0 & 0 \\ 0 & 0 \end{bmatrix}_{3 \times 2}$

**4) Square Matrix :** A matrix with equal number of rows and columns is called a square matrix.

Examples, **i)**  $A = \begin{bmatrix} 5 & -3 & i \\ 1 & 0 & -7 \\ 2i & -8 & 9 \end{bmatrix}_{3 \times 3}$

**ii)**  $C = \begin{bmatrix} -1 & 0 \\ 1 & -5 \end{bmatrix}_{2 \times 2}$

**Note :** A matrix of order  $n \times n$  is also called as square matrix of order n.

Let  $A = [a_{ij}]_{n \times n}$  be a square matrix of order n then

(i) The elements  $a_{11}, a_{22}, a_{33}, \dots, a_{ii}, \dots, a_{nn}$  are called the diagonal elements of matrix A.

Note that the diagonal elements are defined only for a square matrix.

(ii) Elements  $a_{ij}$ , where  $i \neq j$  are called non diagonal elements of matrix A.

(iii) Elements  $a_{ij}$ , where  $i < j$  represent elements above the diagonal.

(iv) Elements  $a_{ij}$ , where  $i > j$  represent elements below the diagonal.

Statements iii) and iv) can be verified by observing square matrices of different orders.

**5) Diagonal Matrix :** A square matrix in which every non-diagonal element is zero, is called a diagonal matrix.

**Ex. i)**  $A = \begin{bmatrix} 5 & 0 & 0 \\ 0 & 0 & 0 \\ 0 & 0 & 9 \end{bmatrix}_{3 \times 3} = \text{diag}(5, 0, 9)$

**ii)**  $B = \begin{bmatrix} -1 & 0 \\ 0 & -5 \end{bmatrix}_{2 \times 2}$

**iii)**  $C = \begin{bmatrix} -1 & 0 & 0 \\ 0 & -2 & 0 \\ 0 & 0 & -3 \end{bmatrix}_{2 \times 2}$

**Note:** If  $a_{11}, a_{22}, a_{33}$  are diagonal elements of a diagonal matrix A of order 3, then we write the matrix A as  $A = \text{Diag}$ .

**6) Scalar Matrix :** A diagonal matrix in which all the diagonal elements are same, is called as a scalar matrix.

For Ex. **i)**  $A = \begin{bmatrix} 5 & 0 & 0 \\ 0 & 5 & 0 \\ 0 & 0 & 5 \end{bmatrix}_{3 \times 3}$

**ii)**  $B = \begin{bmatrix} -2 & 0 \\ 0 & -2 \end{bmatrix}_{2 \times 2}$

**7) Unit or Identity Matrix :** A scalar matrix in which all the diagonal elements are 1 (unity), is called a Unit Matrix or an Identity Matrix. An Identity matrix of order n is denoted by  $I_n$ .

**Ex. i)**  $I_3 = \begin{bmatrix} 1 & 0 & 0 \\ 0 & 1 & 0 \\ 0 & 0 & 1 \end{bmatrix}$  **ii)**  $I_2 = \begin{bmatrix} 1 & 0 \\ 0 & 1 \end{bmatrix}$

**Note:**

1. Every Identity matrix is a Scalar matrix but every scalar matrix need not be Identity matrix. However a scalar matrix is a scalar multiple of the identity matrix.

2. Every scalar matrix is a diagonal matrix but every diagonal matrix need not be a scalar matrix.

**8) Upper Triangular Matrix :** A square matrix in which every element below the diagonal is zero, is called an upper triangular matrix. Matrix  $A = [a_{ij}]_{n \times n}$  is upper triangular if  $a_{ij} = 0$  for all  $i > j$ .

For Ex. i)  $A = \begin{bmatrix} 4 & -1 & 2 \\ 0 & 0 & 3 \\ 0 & 0 & 9 \end{bmatrix}_{3 \times 3}$

ii)  $B = \begin{bmatrix} -3 & 1 \\ 0 & 8 \end{bmatrix}_{2 \times 2}$

**9) Lower Triangular Matrix :** A square matrix in which every element above the diagonal is zero, is called a lower triangular matrix.

Matrix  $A = [a_{ij}]_{n \times n}$  is lower triangular if  $a_{ij} = 0$  for all  $i < j$ .

For Ex. i)  $A = \begin{bmatrix} 2 & 0 & 0 \\ -1 & 1 & 0 \\ -5 & 1 & 9 \end{bmatrix}_{3 \times 3}$

ii)  $B = \begin{bmatrix} 7 & 0 \\ -1 & 3 \end{bmatrix}_{2 \times 2}$

**10) Triangular Matrix :** A square matrix is called a triangular matrix if it is an upper triangular or a lower triangular matrix.

**Note :** The diagonal, scalar, unit and null matrices are also triangular matrices.

**11) Symmetric Matrix :** A square matrix  $A = [a_{ij}]_{n \times n}$  in which  $a_{ij} = a_{ji}$ , for all  $i$  and  $j$ , is called a symmetric matrix.

Ex. i)  $A = \begin{bmatrix} a & h & g \\ h & b & f \\ g & f & c \end{bmatrix}_{3 \times 3}$

ii)  $B = \begin{bmatrix} -3 & 1 \\ 1 & 8 \end{bmatrix}_{2 \times 2}$

iii)  $C = \begin{bmatrix} 2 & 4 & -7 \\ 4 & 5 & -1 \\ -7 & -1 & -3 \end{bmatrix}_{3 \times 3}$

**Note :**

The scalar matrices are symmetric. A null square matrix is symmetric.

**12) Skew-Symmetric Matrix :** A square matrix  $A = [a_{ij}]_{n \times n}$  in which  $a_{ij} = -a_{ji}$ , for all  $i$  and  $j$ , is called a skew symmetric matrix.

Here for  $i = j$ ,  $a_{ii} = -a_{ii}$ ,  $2a_{ii} = 0$ ,  $a_{ii} = 0$  for all  $i = 1, 2, 3, \dots, n$ .

In a skew symmetric matrix each diagonal element is zero.

e.g. i)  $A = \begin{bmatrix} 0 & 5 \\ -5 & 0 \end{bmatrix}_{2 \times 2}$

ii)  $B = \begin{bmatrix} 0 & 4 & -7 \\ -4 & 0 & 5 \\ 7 & -5 & 0 \end{bmatrix}_{3 \times 3}$

**Note :** A null square matrix is also a skew symmetric.

**13) Determinant of a Matrix :** Determinant of a matrix is defined only for a square matrix.

If  $A$  is a square matrix, then the same arrangement of the elements of  $A$  also gives us a determinant, by replacing square brackets by vertical bars. It is denoted by  $|A|$  or  $\det(A)$ .

If  $A = [a_{ij}]_{n \times n}$ , then is of order  $n$ .

Ex. i) If  $A = \begin{bmatrix} 1 & 3 \\ -5 & 4 \end{bmatrix}_{2 \times 2}$

then  $|A| = \begin{vmatrix} 1 & 3 \\ -5 & 4 \end{vmatrix}$

$$\text{ii) If } B = \begin{bmatrix} 2 & -1 & 3 \\ -4 & 1 & 5 \\ 7 & -5 & 0 \end{bmatrix}_{3 \times 3}$$

$$\text{then } |B| = \begin{vmatrix} 2 & -1 & 3 \\ -4 & 1 & 5 \\ 7 & -5 & 0 \end{vmatrix}$$

**14) Singular Matrix :** A square matrix A is said to be a singular matrix if  $|A| = \det(A) = 0$ , otherwise it is said to be a non-singular matrix.

**Ex.** i) If  $A = \begin{bmatrix} 6 & 3 \\ 8 & 4 \end{bmatrix}_{2 \times 2}$

$$\text{then } |A| = \begin{vmatrix} 6 & 3 \\ 8 & 4 \end{vmatrix} = 24 - 24 = 0.$$

Therefore A is a singular matrix.

$$\text{ii) If } B = \begin{bmatrix} 2 & 3 & 4 \\ 3 & 4 & 5 \\ 4 & 5 & 6 \end{bmatrix}_{3 \times 3} \quad \text{then}$$

$$|B| = \begin{vmatrix} 2 & 3 & 4 \\ 3 & 4 & 5 \\ 4 & 5 & 6 \end{vmatrix}$$

$$|B| = 2(24 - 25) - 3(18 - 20) + 4(15 - 16) \\ = -2 + 6 - 4 = 0$$

$|B| = 0$  Therefore B is a singular matrix.

$$\text{iii) } A = \begin{bmatrix} 2 & -1 & 3 \\ -7 & 4 & 5 \\ -2 & 1 & 6 \end{bmatrix}_{3 \times 3} \quad \text{then}$$

$$|A| = \begin{vmatrix} 2 & -1 & 3 \\ -7 & 4 & 5 \\ -2 & 1 & 6 \end{vmatrix}$$

$$|A| = 2(24 - 5) - (-1)(-42 + 10) + 3(-7 + 8) \\ = 38 - 32 + 3 = 9$$

$|A| = 9$ , As  $|A| \neq 0$ , A is a non-singular matrix.

**15) Transpose of a Matrix :** The matrix obtained by interchanging rows and columns of matrix A is called Transpose of matrix A. It is denoted by  $A'$  or  $A^T$ . If A is matrix of order  $m \times n$ , then order of  $A^T$  is  $n \times m$ .

If  $A^T = A' = B$  then  $b_{ij} = a_{ji}$

e.g. i) If  $A = \begin{bmatrix} -1 & 5 \\ 3 & -2 \\ 4 & 7 \end{bmatrix}_{3 \times 2}$

$$\text{then } A^T = \begin{bmatrix} -1 & 3 & 4 \\ 5 & -2 & 7 \end{bmatrix}_{2 \times 3}$$

$$\text{ii) If } B = \begin{bmatrix} 1 & 0 & -2 \\ 8 & -1 & 2 \\ 4 & 3 & 5 \end{bmatrix}_{3 \times 3}$$

$$\text{then } B^T = \begin{bmatrix} 1 & 8 & 4 \\ 0 & -1 & 3 \\ -2 & 2 & 5 \end{bmatrix}_{3 \times 3}$$

**Remark:**

- 1) If A is symmetric then  $A = A^T$
- 2) If B is skew symmetric, then  $B = -B^T$

**Activity :**

Construct a matrix of order  $2 \times 2$  where the  $a_{ij}$  th element is given by  $a_{ij} = \frac{(i+j)^2}{2+i}$

**Solution :** Let  $A = \begin{bmatrix} a_{11} & a_{12} \\ a_{21} & a_{22} \end{bmatrix}_{2 \times 2}$  be the required matrix.

Given that  $a_{ij} = \frac{(i+j)^2}{2+i}$ ,  $a_{11} = \frac{(\dots\dots)^2}{\dots\dots+1} = \frac{4}{3}$ ,

$$a_{12} = \frac{(\dots\dots)^2}{\dots\dots} = \frac{9}{3} = \dots\dots$$

$$a_{21} = \frac{(2+1)^2}{2+2} = \frac{\dots\dots}{4},$$

$$a_{22} = \frac{(\dots\dots\dots)^2}{2+2} = \frac{\dots\dots\dots}{\dots\dots\dots} = 4$$

$$\therefore A = \begin{bmatrix} \frac{4}{3} & \dots \\ \dots & 4 \\ \dots & \dots \end{bmatrix}$$

**SOLVED EXAMPLES**

**Ex. 1)** Show that the matrix  $\begin{bmatrix} x+y & y+z & z+x \\ 1 & 1 & 1 \\ z & x & y \end{bmatrix}$  is a singular matrix.

**Solution :** Let  $A = \begin{bmatrix} x+y & y+z & z+x \\ 1 & 1 & 1 \\ z & x & y \end{bmatrix}$

$$\therefore |A| = \begin{vmatrix} x+y & y+z & z+x \\ 1 & 1 & 1 \\ z & x & y \end{vmatrix}$$

Now  $|A| = (x+y)(y-x) - (y+z)(y-z) + (z+x)(x-z)$   
 $= y^2 - x^2 - y^2 + z^2 + x^2 - z^2$   
 $= 0$

$\therefore A$  is a singular matrix.

**Ex. 2)** If  $A = \begin{bmatrix} -1 & -5 \\ 2 & 0 \\ 3 & -4 \end{bmatrix}_{3 \times 2}$  Find  $(A^T)^T$ .

**Solution :** Let  $A = \begin{bmatrix} -1 & -5 \\ 2 & 0 \\ 3 & -4 \end{bmatrix}_{3 \times 2}$

$$\therefore A^T = \begin{bmatrix} -1 & 2 & 3 \\ -5 & 0 & -4 \end{bmatrix}_{2 \times 3}$$

$$\therefore (A^T)^T = \begin{bmatrix} -1 & -5 \\ 2 & 0 \\ 3 & -4 \end{bmatrix}_{3 \times 2} = A$$

**Ex. 3)** Find a, b, c if the matrix  $A = \begin{bmatrix} 2 & a & 3 \\ -7 & 4 & 5 \\ c & b & 6 \end{bmatrix}$  is a symmetric matrix.

**Solution :** Given that  $A = \begin{bmatrix} 2 & a & 3 \\ -7 & 4 & 5 \\ c & b & 6 \end{bmatrix}$  is a symmetric matrix.

$$a_{ij} = a_{ji} \text{ for all } i \text{ and } j$$

As  $a_{12} = a_{21}$

$$\therefore a = -7$$

As  $a_{32} = a_{23}$

$$\therefore b = 5$$

As  $a_{31} = a_{13}$

$$\therefore c = 3$$

**EXERCISE 4.4**

(1) Construct a matrix  $A = [a_{ij}]_{3 \times 2}$  whose elements

$a_{ij}$  are given by (i)  $a_{ij} = \frac{(i-j)^2}{5-i}$

(ii)  $a_{ij} = i - 3j$  (iii)  $a_{ij} = \frac{(i+j)^3}{5}$

(2) Classify the following matrices as, a row, a column, a square, a diagonal, a scalar, a unit, an upper triangular, a lower triangular, a symmetric or a skew-symmetric matrix.

(i)  $\begin{bmatrix} 3 & -2 & 4 \\ 0 & 0 & -5 \\ 0 & 0 & 0 \end{bmatrix}$  (ii)  $\begin{bmatrix} 0 & 4 & 7 \\ -4 & 0 & -3 \\ -7 & 3 & 0 \end{bmatrix}$

(iii)  $\begin{bmatrix} 5 \\ 4 \\ -3 \end{bmatrix}$  (iv)  $\begin{bmatrix} 9 & \sqrt{2} & -3 \end{bmatrix}$

(v)  $\begin{bmatrix} 6 & 0 \\ 0 & 6 \end{bmatrix}$       (vi)  $\begin{bmatrix} 2 & 0 & 0 \\ 3 & -1 & 0 \\ -7 & 3 & 1 \end{bmatrix}$

(vii)  $\begin{bmatrix} 3 & 0 & 0 \\ 0 & 5 & 0 \\ 0 & 0 & \frac{1}{3} \end{bmatrix}$       (viii)  $\begin{bmatrix} 10 & -15 & 27 \\ -15 & 0 & \sqrt{34} \\ 27 & \sqrt{34} & \frac{5}{3} \end{bmatrix}$

(ix)  $\begin{bmatrix} 1 & 0 & 0 \\ 0 & 1 & 0 \\ 0 & 0 & 1 \end{bmatrix}$       (x)  $\begin{bmatrix} 0 & 0 & 1 \\ 0 & 1 & 0 \\ 1 & 0 & 0 \end{bmatrix}$

(3) Which of the following matrices are singular or non singular ?

(i)  $\begin{bmatrix} a & b & c \\ p & q & r \\ 2a-p & 2b-q & 2c-r \end{bmatrix}$

(ii)  $\begin{bmatrix} 5 & 0 & 5 \\ 1 & 99 & 100 \\ 6 & 99 & 105 \end{bmatrix}$       (iii)  $\begin{bmatrix} 3 & 5 & 7 \\ -2 & 1 & 4 \\ 3 & 2 & 5 \end{bmatrix}$

(iv)  $\begin{bmatrix} 7 & 5 \\ -4 & 7 \end{bmatrix}$

(4) Find k if the following matrices are singular

(i)  $\begin{bmatrix} 7 & 3 \\ -2 & k \end{bmatrix}$       (ii)  $\begin{bmatrix} 4 & 3 & 1 \\ 7 & k & 1 \\ 10 & 9 & 1 \end{bmatrix}$

(iii)  $\begin{bmatrix} k-1 & 2 & 3 \\ 3 & 1 & 2 \\ 1 & -2 & 4 \end{bmatrix}$

(5) If  $A = \begin{bmatrix} 5 & 1 & -1 \\ 3 & 2 & 0 \end{bmatrix}$ , Find  $(A^T)^T$ .

(6) If  $A = \begin{bmatrix} 7 & 3 & 1 \\ -2 & -4 & 1 \\ 5 & 9 & 1 \end{bmatrix}$ , Find  $(A^T)^T$ .

(7) Find a, b, c if  $\begin{bmatrix} 1 & \frac{3}{5} & a \\ b & -5 & -7 \\ -4 & c & 0 \end{bmatrix}$  is a symmetric matrix.

(8) Find x, y, z if  $\begin{bmatrix} 0 & -5i & x \\ y & 0 & z \\ \frac{3}{2} & -\sqrt{2} & 0 \end{bmatrix}$  is a skew symmetric matrix.

(9) For each of the following matrices, using its transpose state whether it is a symmetric, a skew-symmetric or neither.

(i)  $\begin{bmatrix} 1 & 2 & -5 \\ 2 & -3 & 4 \\ -5 & 4 & 9 \end{bmatrix}$       (ii)  $\begin{bmatrix} 2 & 5 & 1 \\ -5 & 4 & 6 \\ -1 & -6 & 3 \end{bmatrix}$

(iii)  $\begin{bmatrix} 0 & 1+2i & i-2 \\ -1-2i & 0 & -7 \\ 2-i & 7 & 0 \end{bmatrix}$

(10) Construct the matrix  $A = [a_{ij}]_{3 \times 3}$  where  $a_{ij} = i-j$ . State whether A is symmetric or skew symmetric.

### 4.5 Algebra of Matrices :

- (1) Equality of matrices
- (2) Multiplication of a matrix by a scalar
- (3) Addition of matrices
- (4) Multiplication of two matrices.

**(1) Equality of matrices :** Two matrices A and B are said to be equal if (i) order of A = order of B and (ii) corresponding elements of A and B are same, that is if  $a_{ij} = b_{ij}$  for; all  $i, j$  and symbolically written as  $A=B$ .

**Ex.** (i) If  $A = \begin{bmatrix} 15 & 14 \\ 12 & 10 \end{bmatrix}_{2 \times 2}$

$B = \begin{bmatrix} 15 & 14 \\ 10 & 12 \end{bmatrix}_{2 \times 2}$  and  $C = \begin{bmatrix} 15 & 14 \\ 10 & 12 \end{bmatrix}_{2 \times 2}$

Here  $A \neq B$ ,  $A \neq C$  but  $B = C$  by definition of equality.

**Ex.** (ii) If  $\begin{bmatrix} 2a-b & 4 \\ -7 & 2 \end{bmatrix} = \begin{bmatrix} 1 & 4 \\ -7 & a+3b \end{bmatrix}$

then using definition of equality of matrices, we have  $2a - b = 1$  .....(1) and  $a + 3b = 2$  ..... (2)

Solving equations (1) and (2), we get  $a = \frac{5}{7}$  and  $b = \frac{3}{7}$

**(2) Multiplication of a Matrix by a scalar:**

If A is any matrix and k is a scalar, then the matrix obtained by multiplying each element of A by the scalar k is called the scalar multiple of the given matrix A and is denoted by kA.

Thus if  $A = [a_{ij}]_{m \times n}$  and k is any scalar then  $kA = [ka_{ij}]_{m \times n}$ .

Here the order of matrix A and kA are same.

**Ex.**  $A = \begin{bmatrix} -1 & 5 \\ 3 & -2 \\ 4 & 7 \end{bmatrix}_{3 \times 2}$  and  $k = \frac{3}{2}$ ,

then  $kA = \frac{3}{2}A$

$$= \frac{3}{2} \begin{bmatrix} -1 & 5 \\ 3 & -2 \\ 4 & 7 \end{bmatrix}_{3 \times 2} = \begin{bmatrix} -\frac{3}{2} & \frac{15}{2} \\ \frac{9}{2} & -3 \\ 6 & \frac{21}{2} \end{bmatrix}_{3 \times 2}$$

**(3) Addition of Two matrices :** A and B are two matrices of same order. Their addition denoted by  $A + B$  is a matrix obtained by adding the corresponding elements of A and B.

**Note:**  $A+B$  is possible only when A and B are of same order.

$A+B$  is of the same order as that of A and B.

Thus if  $A = [a_{ij}]_{m \times n}$  and  $B = [b_{ij}]_{m \times n}$  then  $A+B = [a_{ij} + b_{ij}]_{m \times n}$

**Ex.**  $A = \begin{bmatrix} 2 & 3 & 1 \\ -1 & -2 & 0 \end{bmatrix}_{2 \times 3}$  and

$B = \begin{bmatrix} -4 & 3 & 1 \\ 5 & 7 & -8 \end{bmatrix}_{2 \times 3}$  Find  $A+B$ .

**Solution :** By definition of addition,

$$A+B = \begin{bmatrix} 2+(-4) & 3+3 & 1+1 \\ -1+5 & -2+7 & 0+(-8) \end{bmatrix}_{2 \times 3}$$

$$= \begin{bmatrix} -2 & 6 & 2 \\ 4 & 5 & -8 \end{bmatrix}_{2 \times 3}$$

**Note :** If A and B are two matrices of the same order then subtraction of the two matrices is defined as,  $A-B = A+(-B)$ , where  $-B$  is the negative of matrix B.

**Ex.** If  $A = \begin{bmatrix} -1 & 4 \\ 3 & -2 \\ 0 & 5 \end{bmatrix}_{3 \times 2}$  and  $B = \begin{bmatrix} -1 & 5 \\ 2 & -6 \\ 4 & 9 \end{bmatrix}_{3 \times 2}$ ,  
Find  $A-B$ .

**Solution :** By definition of subtraction,

$$A-B = A+(-B) = \begin{bmatrix} -1 & 4 \\ 3 & -2 \\ 0 & 5 \end{bmatrix} + \begin{bmatrix} 1 & -5 \\ -2 & 6 \\ -4 & -9 \end{bmatrix}$$

$$= \begin{bmatrix} -1+1 & 4+(-5) \\ 3+(-2) & -2+6 \\ 0+(-4) & 5+(-9) \end{bmatrix} = \begin{bmatrix} 0 & -1 \\ 1 & 4 \\ -4 & -4 \end{bmatrix}$$

**Some Results on addition and scalar multiplication :** If A, B, C are three matrices conformable for addition and  $\alpha, \beta$  are scalars, then

- (i)  $A+B = B+A$ , That is, the matrix addition is commutative.
- (ii)  $(A+B)+C = A+(B+C)$ , That is, the matrix addition is associative.
- (iii) For matrix A, we have  $A+O = O+A = A$ , That is, a zero matrix is conformable for addition and it is the identity for matrix addition.
- (iv) For a matrix A, we have  $A+(-A) = (-A)+A = O$ , where O is a zero matrix conformable with matrix A for addition. Where  $(-A)$  is additive inverse of A.
- (v)  $\alpha(A \pm B) = \alpha A \pm \alpha B$
- (vi)  $(\alpha \pm \beta)A = \alpha A \pm \beta A$
- (vii)  $\alpha(\beta \cdot A) = (\alpha \cdot \beta) \cdot A$
- (viii)  $OA = O$

**SOLVED EXAMPLES**

**Ex. 1)** If  $A = \begin{bmatrix} 5 & -3 \\ 1 & 0 \\ -4 & -2 \end{bmatrix}$  and

$B = \begin{bmatrix} 2 & 7 \\ -3 & 1 \\ 2 & -2 \end{bmatrix}$ , find  $2A - 3B$ .

**Solution :** Let  $2A - 3B$

$$= 2 \begin{bmatrix} 5 & -3 \\ 1 & 0 \\ -4 & -2 \end{bmatrix} - 3 \begin{bmatrix} 2 & 7 \\ -3 & 1 \\ 2 & -2 \end{bmatrix}$$

$$= \begin{bmatrix} 10 & -6 \\ 2 & 0 \\ -8 & -4 \end{bmatrix} + \begin{bmatrix} -6 & -21 \\ 9 & -3 \\ -6 & 6 \end{bmatrix}$$

$$= \begin{bmatrix} 10-6 & -6-21 \\ 2+9 & 0-3 \\ -8-6 & -4+6 \end{bmatrix} = \begin{bmatrix} 4 & -27 \\ 11 & -3 \\ -14 & 2 \end{bmatrix}$$

**Ex. 2)** If  $A = \text{diag}(2, -5, 9)$ ,  $B = \text{diag}(-3, 7, -14)$  and  $C = \text{diag}(1, 0, 3)$ , find  $B-A-C$ .

**Solution :**  $B-A-C = B-(A+C)$

$$\begin{aligned} \text{Now, } A+C &= \text{diag}(2, -5, 9) + \text{diag}(1, 0, 3) \\ &= \text{diag}(3, -5, 12) \end{aligned}$$

$$\begin{aligned} B-A-C &= B-(A+C) \\ &= \text{diag}(-3, 7, -14) - \text{diag}(3, -5, 12) \end{aligned}$$

$$= \text{diag}(-6, 12, -26) = \begin{bmatrix} -6 & 0 & 0 \\ 0 & 12 & 0 \\ 0 & 0 & -26 \end{bmatrix}$$

**Ex. 3)** If  $A = \begin{bmatrix} 2 & 3 & -1 \\ 4 & 7 & 5 \end{bmatrix}$ ,  $B = \begin{bmatrix} 1 & 3 & 2 \\ 4 & 6 & -1 \end{bmatrix}$  and

$C = \begin{bmatrix} 1 & -1 & 6 \\ 0 & 2 & -5 \end{bmatrix}$ , find the matrix X such that

$$3A - 2B + 4X = 5C.$$

**Solution :** Since  $3A - 2B + 4X = 5C$

$$\therefore 4X = 5C - 3A + 2B$$

$$\begin{aligned} \therefore 4X &= 5 \begin{bmatrix} 1 & -1 & 6 \\ 0 & 2 & -5 \end{bmatrix} - 3 \begin{bmatrix} 2 & 3 & -1 \\ 4 & 7 & 5 \end{bmatrix} \\ &\quad + 2 \begin{bmatrix} 1 & 3 & 2 \\ 4 & 6 & -1 \end{bmatrix} \end{aligned}$$

$$= \begin{bmatrix} 5 & -5 & 30 \\ 0 & 10 & -25 \end{bmatrix} + \begin{bmatrix} -6 & -9 & 3 \\ -12 & -21 & -15 \end{bmatrix}$$

$$+ \begin{bmatrix} 2 & 6 & 4 \\ 8 & 12 & -2 \end{bmatrix}$$

$$= \begin{bmatrix} 5-6+2 & -5-9+6 & 30+3+4 \\ 0-12+8 & 10-21+12 & -25-15-2 \end{bmatrix}$$

$$= \begin{bmatrix} 1 & -8 & 37 \\ -4 & 1 & -42 \end{bmatrix}$$

$$\therefore X = \frac{1}{4} \begin{bmatrix} 1 & -8 & 37 \\ -4 & 1 & -42 \end{bmatrix} = \begin{bmatrix} \frac{1}{4} & -2 & \frac{37}{4} \\ -1 & \frac{1}{4} & -\frac{21}{2} \end{bmatrix}$$

**Ex. 4)** If  $\begin{bmatrix} 2x+1 & -1 \\ 3 & 4y \end{bmatrix} + \begin{bmatrix} -1 & 6 \\ 3 & 0 \end{bmatrix} = \begin{bmatrix} 4 & 5 \\ 6 & 12 \end{bmatrix}$ ,

find  $x$  and  $y$ .

**Solution :** Given  $\begin{bmatrix} 2x+1 & -1 \\ 3 & 4y \end{bmatrix} + \begin{bmatrix} -1 & 6 \\ 3 & 0 \end{bmatrix}$

$$= \begin{bmatrix} 4 & 5 \\ 6 & 12 \end{bmatrix}$$

$$\therefore \begin{bmatrix} 2x & 5 \\ 6 & 4y \end{bmatrix} = \begin{bmatrix} 4 & 5 \\ 6 & 12 \end{bmatrix}$$

$\therefore$  Using definition of equality of matrices, we have

$$2x = 4, \quad 4y = 12 \quad \therefore x = 2, \quad y = 3$$

**Ex. 5)** If  $X + Y = \begin{bmatrix} 2 & -1 \\ 1 & 3 \\ -3 & -2 \end{bmatrix}$  and

$$X - 2Y$$

$$= \begin{bmatrix} -2 & 1 \\ 3 & -1 \\ 4 & -2 \end{bmatrix} \text{ then find } X, Y.$$

**Solution :** Let  $A = \begin{bmatrix} 2 & -1 \\ 1 & 3 \\ -3 & -2 \end{bmatrix}$  and  $B = \begin{bmatrix} -2 & 1 \\ 3 & -1 \\ 4 & -2 \end{bmatrix}$

Let,  $X + Y = A$  .... (1),  $X - 2Y = B$  .....(2),  
Solving (1) and (2) for  $X$  and  $Y$

By (1) - (2),  $3Y = A - B$ ,  $\therefore Y = \frac{1}{3} (A - B)$

$$\therefore Y = \frac{1}{3} \left\{ \begin{bmatrix} 2 & -1 \\ 1 & 3 \\ -3 & -2 \end{bmatrix} - \begin{bmatrix} -2 & 1 \\ 3 & -1 \\ 4 & -2 \end{bmatrix} \right\} = \frac{1}{3} \begin{bmatrix} 4 & -2 \\ -2 & 4 \\ -7 & 0 \end{bmatrix}$$

$$= \begin{bmatrix} \frac{4}{3} & -\frac{2}{3} \\ -\frac{2}{3} & \frac{4}{3} \\ -\frac{7}{3} & 0 \end{bmatrix}$$

From (1)  $X + Y = A$ ,  $\therefore X = A - Y$ ,

$$\therefore X = \begin{bmatrix} 2 & -1 \\ 1 & 3 \\ -3 & -2 \end{bmatrix} - \begin{bmatrix} \frac{4}{3} & -\frac{2}{3} \\ -\frac{2}{3} & \frac{4}{3} \\ -\frac{7}{3} & 0 \end{bmatrix}$$

$$X = \begin{bmatrix} 2 - \frac{4}{3} & -1 + \frac{2}{3} \\ 1 + \frac{2}{3} & 3 - \frac{4}{3} \\ -3 + \frac{7}{3} & -2 + 0 \end{bmatrix} = \begin{bmatrix} \frac{2}{3} & -\frac{1}{3} \\ \frac{5}{3} & \frac{5}{3} \\ -\frac{2}{3} & -2 \end{bmatrix}$$

### EXERCISE 4.5

(1) If  $A = \begin{bmatrix} 2 & -3 \\ 5 & -4 \\ -6 & 1 \end{bmatrix}$ ,  $B = \begin{bmatrix} -1 & 2 \\ 2 & 2 \\ 0 & 3 \end{bmatrix}$  and

$$C = \begin{bmatrix} 4 & 3 \\ -1 & 4 \\ -2 & 1 \end{bmatrix} \text{ Show that (i) } A + B = B + A$$

(ii)  $(A+B)+C = A+(B+C)$

- (2) If  $A = \begin{bmatrix} 1 & -2 \\ 5 & 3 \end{bmatrix}$ ,  $B = \begin{bmatrix} 1 & -3 \\ 4 & -7 \end{bmatrix}$ , then find the matrix  $A - 2B + 6I$ , where  $I$  is the unit matrix of order 2.

- (3) If  $A = \begin{bmatrix} 1 & 2 & -3 \\ -3 & 7 & -8 \\ 0 & -6 & 1 \end{bmatrix}$ ,  $B = \begin{bmatrix} 9 & -1 & 2 \\ -4 & 2 & 5 \\ 4 & 0 & -3 \end{bmatrix}$  then find the matrix  $C$  such that  $A+B+C$  is a zero matrix.

- (4) If  $A = \begin{bmatrix} 1 & -2 \\ 3 & -5 \\ -6 & 0 \end{bmatrix}$ ,  $B = \begin{bmatrix} -1 & -2 \\ 4 & 2 \\ 1 & 5 \end{bmatrix}$  and  $C = \begin{bmatrix} 2 & 4 \\ -1 & -4 \\ -3 & 6 \end{bmatrix}$ , find the matrix  $X$  such that  $3A - 4B + 5X = C$ .

- (5) Solve the following equations for  $X$  and  $Y$ , if  $3X - Y = \begin{bmatrix} 1 & -1 \\ -1 & 1 \end{bmatrix}$  and  $X - 3Y = \begin{bmatrix} 0 & -1 \\ 0 & -1 \end{bmatrix}$

- (6) Find matrices  $A$  and  $B$ , if  $2A - B = \begin{bmatrix} 6 & -6 & 0 \\ -4 & 2 & 1 \end{bmatrix}$  and  $A - 2B = \begin{bmatrix} 3 & 2 & 8 \\ -2 & 1 & -7 \end{bmatrix}$

- (7) Simplify,  $\cos\theta \begin{bmatrix} \cos\theta & \sin\theta \\ -\sin\theta & \cos\theta \end{bmatrix} +$

$$\sin\theta \begin{bmatrix} \sin\theta & -\cos\theta \\ \cos\theta & \sin\theta \end{bmatrix}$$

- (8) If  $A = \begin{bmatrix} i & 2i \\ -3 & 2 \end{bmatrix}$  and  $B = \begin{bmatrix} 2i & i \\ 2 & -3 \end{bmatrix}$ , where  $\sqrt{-1} = i$ , find  $A+B$  and  $A-B$ . Show that  $A+B$  is a singular. Is  $A-B$  a singular? Justify your answer.

- (9) Find  $x$  and  $y$ , if  $\begin{bmatrix} 2x+y & -1 & 1 \\ 3 & 4y & 4 \end{bmatrix} + \begin{bmatrix} -1 & 6 & 4 \\ 3 & 0 & 3 \end{bmatrix} = \begin{bmatrix} 3 & 5 & 5 \\ 6 & 18 & 7 \end{bmatrix}$

- (10) If  $\begin{bmatrix} 2a+b & 3a-b \\ c+2d & 2c-d \end{bmatrix} = \begin{bmatrix} 2 & 3 \\ 4 & -1 \end{bmatrix}$ , find  $a$ ,  $b$ ,  $c$  and  $d$ .

- (11) There are two book shops owned by Suresh and Ganesh. Their sales (in Rupees) for books in three subject – Physics, Chemistry and Mathematics for two months, July and August 2017 are given by two matrices  $A$  and  $B$ .

July sales (in Rupees), Physics Chemistry Mathematics.

$$A = \begin{bmatrix} 5600 & 6750 & 8500 \\ 6650 & 7055 & 8905 \end{bmatrix} \begin{array}{l} \text{First Row Suresh/} \\ \text{Second Row Ganesh} \end{array}$$

August sales (in Rupees), Physics Chemistry Mathematics

$$B = \begin{bmatrix} 6650 & 7055 & 8905 \\ 7000 & 7500 & 10200 \end{bmatrix} \begin{array}{l} \text{First Row} \\ \text{Suresh/ Second Row Ganesh then,} \end{array}$$

- (i) Find the increase in sales in Rupees from July to August 2017.  
 (ii) If both book shops got 10 % profit in the month of August 2017, find the profit for each book seller in each subject in that month.

#### (4) Algebra of Matrices (continued)

Two Matrices A and B are said to be conformable for the product AB if the number of columns in A is equal to the number of rows in B. i.e. A is of order  $m \times n$  and B is of order  $n \times p$ .

In This case the product AB is a matrix defined as follows.

$$A_{m \times n} \times B_{n \times p} = C_{m \times p}, \text{ where } C_{ij} = \sum_{k=1}^n a_{ik} b_{kj}$$

$$\text{If } A = [a_{ik}]_{m \times n} = \begin{bmatrix} a_{11} & a_{12} & \dots & a_{1k} & \dots & a_{1n} \\ a_{21} & a_{22} & \dots & a_{2k} & \dots & a_{2n} \\ a_{31} & a_{32} & \dots & a_{3k} & \dots & a_{3n} \\ a_{i1} & a_{i2} & \dots & a_{ik} & \dots & a_{in} \\ a_{m1} & a_{m2} & \dots & a_{mk} & \dots & a_{mn} \end{bmatrix} \rightarrow i^{\text{th}} \text{ row}$$

$$B = [b_{kj}]_{n \times p} = \begin{bmatrix} b_{11} & b_{12} & \dots & b_{1j} & \dots & b_{1p} \\ b_{21} & b_{22} & \dots & b_{2j} & \dots & b_{2p} \\ b_{31} & b_{32} & \dots & b_{3j} & \dots & b_{3p} \\ b_{p1} & b_{p2} & \dots & b_{nj} & \dots & b_{np} \end{bmatrix}$$

↓  
 $j^{\text{th}}$  column

then

$$C_{ij} = a_{i1} b_{1j} + a_{i2} b_{2j} + \dots + a_{in} b_{nj}$$

#### SOLVED EXAMPLES

**Ex.1 :** If  $A = [a_{11} \ a_{12} \ a_{13}]$  and  $B = \begin{bmatrix} b_{11} \\ b_{21} \\ b_{31} \end{bmatrix}$

Find AB.

**Solution :** Since number of columns of A = number of rows of B = 3

Therefore product AB is defined and its order is 1.  $(A)_{1 \times 3} (B)_{3 \times 1} = (AB)_{1 \times 1}$

$$AB = [a_{11} \times b_{11} + a_{12} \times b_{21} + a_{13} \times b_{31}]$$

**Ex.2 :** Let  $A = [1 \ 3 \ 2]_{1 \times 3}$  and  $B = \begin{bmatrix} 3 \\ 2 \\ 1 \end{bmatrix}_{3 \times 1}$ , find AB.

Does BA exist? If yes, find it.

**Solution :** Product AB is defined and order of AB is 1.

$$\therefore AB = [1 \ 3 \ 2] \begin{bmatrix} 3 \\ 2 \\ 1 \end{bmatrix} = [1 \times 3 + 3 \times 2 + 2 \times 1] \\ = [11]_{1 \times 1}$$

Again since number of column of B = number of rows of A=1

$\therefore$  The product BA also is defined and order of BA is 3.

$$BA = \begin{bmatrix} 3 \\ 2 \\ 1 \end{bmatrix}_{3 \times 1} [1 \ 3 \ 2]_{1 \times 3} = \begin{bmatrix} 3 \times 1 & 3 \times 3 & 3 \times 2 \\ 2 \times 1 & 2 \times 3 & 2 \times 2 \\ 1 \times 1 & 1 \times 3 & 1 \times 2 \end{bmatrix}_{3 \times 3} \\ = \begin{bmatrix} 3 & 9 & 6 \\ 2 & 6 & 4 \\ 1 & 3 & 2 \end{bmatrix}_{3 \times 3}$$

**Remark :** Here AB and BA both are defined but  $AB \neq BA$ .

**Ex.3 :**  $A = \begin{bmatrix} -1 & -2 \\ -3 & 2 \\ 1 & 0 \end{bmatrix}_{3 \times 2}$ ,  $B = \begin{bmatrix} 1 & 2 \\ -1 & -2 \end{bmatrix}_{2 \times 2}$

Find AB and BA which ever exist.

**Solution :** Here A is order of  $3 \times 2$  and B is of order  $2 \times 2$ . By conformability of product, AB is defined but BA is not defined.

$$\therefore AB = \begin{bmatrix} -1 & -2 \\ -3 & 2 \\ 1 & 0 \end{bmatrix} \begin{bmatrix} 1 & 2 \\ -1 & -2 \end{bmatrix} \\ = \begin{bmatrix} -1+2 & -2+4 \\ -3-2 & -6-4 \\ 1+0 & 2+0 \end{bmatrix} = \begin{bmatrix} 1 & 2 \\ -3 & -10 \\ 1 & 0 \end{bmatrix}$$

**Ex.4 :** Let  $A = \begin{bmatrix} 3 & 2 & -1 \\ -2 & 5 & 4 \end{bmatrix}_{2 \times 3}$ ,

$$B = \begin{bmatrix} 3 & -3 \\ -4 & 2 \end{bmatrix}_{2 \times 2}$$

Find AB and BA which ever exist.

**Solution :** Since number of columns of A  $\neq$  number of rows of B. Product of AB is not defined. But number of columns of B = number of rows of A = 2, the product BA exists,

$$\begin{aligned} \therefore BA &= \begin{bmatrix} 3 & -3 \\ -4 & 2 \end{bmatrix} \begin{bmatrix} 3 & 2 & -1 \\ -2 & 5 & 4 \end{bmatrix} \\ &= \begin{bmatrix} 9+6 & 6-15 & -3-12 \\ -12-4 & -8+10 & 4+8 \end{bmatrix} \\ &= \begin{bmatrix} 15 & -9 & -15 \\ -16 & 2 & 12 \end{bmatrix} \end{aligned}$$

**Ex.5 :** Let  $A = \begin{bmatrix} 4 & -3 \\ 5 & 2 \end{bmatrix}$  and  $B = \begin{bmatrix} -1 & 3 \\ 4 & -2 \end{bmatrix}$  Find

AB and BA which ever exist.

**Solution :** Since A and B are two matrix of same order  $2 \times 2$ .

$\therefore$  Both the product AB and BA exist and are of same order  $2 \times 2$

$$\begin{aligned} AB &= \begin{bmatrix} 4 & -3 \\ 5 & 2 \end{bmatrix} \begin{bmatrix} -1 & 3 \\ 4 & -2 \end{bmatrix} \\ &= \begin{bmatrix} -4-12 & 12+6 \\ -5+8 & 15-4 \end{bmatrix} = \begin{bmatrix} -16 & 18 \\ 3 & 11 \end{bmatrix} \\ BA &= \begin{bmatrix} -1 & 3 \\ 4 & -2 \end{bmatrix} \begin{bmatrix} 4 & -3 \\ 5 & 2 \end{bmatrix} = \begin{bmatrix} -4+15 & 3+6 \\ 16-10 & -12-4 \end{bmatrix} \\ &= \begin{bmatrix} 11 & 9 \\ 6 & -16 \end{bmatrix} \end{aligned}$$

Here  $AB \neq BA$

**Note :**

From the above solved numerical Examples, for the given matrices A and B we note that,

- i) If AB exists , BA may or may not exist.
- ii) If BA exists , AB may or may not exist.
- iii) If AB and BA both exist they may not be equal.

**4.6 Properties of Matrix Multiplication :**

- 1) For matrices A and B, matrix multiplication is not commutative that is  $AB \neq BA$ .
- 2) For three matrices A,B,C. Matrix multiplication is associative. That is  $(AB)C = A(BC)$  if orders of matrices are suitable for multiplication.

e.g. Let  $A = \begin{bmatrix} 1 & 2 \\ 4 & 3 \end{bmatrix}$ ,  $B = \begin{bmatrix} 1 & -1 & 2 \\ 0 & -1 & 3 \end{bmatrix}$ ,

$$C = \begin{bmatrix} -2 & 1 \\ 3 & -1 \\ 0 & 2 \end{bmatrix}$$

$$\begin{aligned} \text{Then } AB &= \begin{bmatrix} 1 & 2 \\ 4 & 3 \end{bmatrix} \begin{bmatrix} 1 & -1 & 2 \\ 0 & -1 & 3 \end{bmatrix} \\ &= \begin{bmatrix} 1+0 & -1-2 & 2+6 \\ 4+0 & -4-3 & 8+9 \end{bmatrix} = \begin{bmatrix} 1 & -3 & 8 \\ 4 & -7 & 17 \end{bmatrix} \end{aligned}$$

$$\begin{aligned} (AB)C &= \begin{bmatrix} 1 & -3 & 8 \\ 4 & -7 & 17 \end{bmatrix} \begin{bmatrix} -2 & 1 \\ 3 & -1 \\ 0 & 2 \end{bmatrix} \\ &= \begin{bmatrix} -2-9+0 & 1+3+16 \\ -8-21+0 & 4+7+34 \end{bmatrix} = \begin{bmatrix} -11 & 20 \\ -29 & 45 \end{bmatrix} \end{aligned} \dots(1)$$

$$\begin{aligned} \therefore BC &= \begin{bmatrix} 1 & -1 & 2 \\ 0 & -1 & 3 \end{bmatrix} \begin{bmatrix} -2 & 1 \\ 3 & -1 \\ 0 & 2 \end{bmatrix} \\ &= \begin{bmatrix} -2-3+0 & 1+1+4 \\ 0-3+0 & 0+1+6 \end{bmatrix} = \begin{bmatrix} -5 & 6 \\ -3 & 7 \end{bmatrix} \end{aligned}$$

$$A(BC) = \begin{bmatrix} 1 & 2 \\ 4 & 3 \end{bmatrix} \begin{bmatrix} -5 & 6 \\ -3 & 7 \end{bmatrix}$$

$$= \begin{bmatrix} -5-6 & 6+14 \\ -20-9 & 24+21 \end{bmatrix} = \begin{bmatrix} -11 & 20 \\ -29 & 45 \end{bmatrix} \dots\dots(2)$$

From (1) and (2),  $(AB)C = A(BC)$

3) For three matrices A,B,C, multiplication is distributive over addition.

i)  $A(B+C) = AB + AC$   
(left distributive law)

ii)  $(B+C)A = BA + CA$   
(right distributive law)

These laws can be verified by examples.

4) For a given square matrix A there exists a unit matrix I of the same order as that of A, such that  $AI = IA = A$ .

I is called Identity matrix for matrix multiplication.

e.g. Let  $A = \begin{bmatrix} 3 & -2 & -1 \\ 2 & 0 & 4 \\ 1 & 3 & 2 \end{bmatrix}$ ,

and  $I = \begin{bmatrix} 1 & 0 & 0 \\ 0 & 1 & 0 \\ 0 & 0 & 1 \end{bmatrix}$

Then  $AI = \begin{bmatrix} 3 & -2 & -1 \\ 2 & 0 & 4 \\ 1 & 3 & 2 \end{bmatrix} \begin{bmatrix} 1 & 0 & 0 \\ 0 & 1 & 0 \\ 0 & 0 & 1 \end{bmatrix}$

$$= \begin{bmatrix} 3+0+0 & 0-2+0 & 0+0-1 \\ 2+0+0 & 0+0+0 & 0+0+4 \\ 1+0+0 & 0+3+0 & 0+0+2 \end{bmatrix}$$

$$= \begin{bmatrix} 3 & -2 & -1 \\ 2 & 0 & 4 \\ 1 & 3 & 2 \end{bmatrix} = IA = A$$

5) For any matrix A there exists a null matrix O such that a)  $AO = O$  and b)  $OA = O$ .

6) The product of two non zero matrices can be a zero matrix. That is  $AB = O$  but  $A \neq O, B \neq O$

e.g. Let  $A = \begin{bmatrix} 1 & 0 \\ 2 & 0 \end{bmatrix}$ ,  $B = \begin{bmatrix} 0 & 0 \\ -1 & 1 \end{bmatrix}$ ,

Here  $A \neq O, B \neq O$  but  $AB = \begin{bmatrix} 1 & 0 \\ 2 & 0 \end{bmatrix} \begin{bmatrix} 0 & 0 \\ -1 & 1 \end{bmatrix}$

That is  $AB = \begin{bmatrix} 0 & 0 \\ 0 & 0 \end{bmatrix} = O$

7) Positive integral powers of a square matrix A are obtained by repeated multiplication of A by itself. That is  $A^2 = AA, A^3 = AAA, \dots\dots$ ,

$A^n = AA \dots n \text{ times}$

**(Activity)**

If  $A = \begin{bmatrix} 1 & -5 \\ 6 & 7 \end{bmatrix}$ ,  $B = \begin{bmatrix} 2 & -3 \\ 4 & 8 \end{bmatrix}$ ,

Find  $AB-2I$ , where I is unit matrix of order 2.

**Solution :** Given  $A = \begin{bmatrix} 1 & -5 \\ 6 & 7 \end{bmatrix}$ ,  $B = \begin{bmatrix} 2 & -3 \\ 4 & 8 \end{bmatrix}$

Consider  $AB-2I = \begin{bmatrix} 1 & -5 \\ 6 & 7 \end{bmatrix} \begin{bmatrix} 2 & -3 \\ 4 & 8 \end{bmatrix} - 2 \begin{bmatrix} \dots & \dots \\ \dots & \dots \end{bmatrix}$

$$\therefore AB-2I = \begin{bmatrix} \dots & -3-40 \\ 12+28 & \dots \end{bmatrix} - \begin{bmatrix} \dots & 0 \\ 0 & \dots \end{bmatrix}$$

$$= \begin{bmatrix} \dots & -43 \\ 40 & \dots \end{bmatrix} - \begin{bmatrix} \dots & 0 \\ 0 & \dots \end{bmatrix}$$

$$\therefore AB-2I = \begin{bmatrix} \dots & -43 \\ 40 & \dots \end{bmatrix}$$

**SOLVED EXAMPLES**

**Ex. 1 :** If  $A = \begin{bmatrix} 1 & -1 & 2 \\ 0 & -1 & 3 \end{bmatrix}$ ,  $B = \begin{bmatrix} -2 & 1 \\ 3 & -1 \\ 0 & 2 \end{bmatrix}$ ,

show that matrix AB is non singular.

**Solution :** let  $AB = \begin{bmatrix} 1 & -1 & 2 \\ 0 & -1 & 3 \end{bmatrix} \begin{bmatrix} -2 & 1 \\ 3 & -1 \\ 0 & 2 \end{bmatrix}$

$$= \begin{bmatrix} -2-3+0 & 1+1+4 \\ 0-3+0 & 0+1+6 \end{bmatrix}$$

$$= \begin{bmatrix} -5 & 6 \\ -3 & 7 \end{bmatrix},$$

$$\therefore |AB| = \begin{vmatrix} -5 & 6 \\ -3 & 7 \end{vmatrix}$$

$$= -35 + 18 = -17 \neq 0$$

$\therefore$  matrix AB is nonsingular.

**Ex. 2 :** If  $A = \begin{bmatrix} 1 & 3 & 3 \\ 3 & 1 & 3 \\ 3 & 3 & 1 \end{bmatrix}$  prove that  $A^2 - 5A$  is a scalar matrix.

**Solution :** Let  $A^2 = A.A$

$$= \begin{bmatrix} 1 & 3 & 3 \\ 3 & 1 & 3 \\ 3 & 3 & 1 \end{bmatrix} \begin{bmatrix} 1 & 3 & 3 \\ 3 & 1 & 3 \\ 3 & 3 & 1 \end{bmatrix}$$

$$= \begin{bmatrix} 1+9+9 & 3+3+9 & 3+9+3 \\ 3+3+9 & 9+1+9 & 9+3+3 \\ 3+9+3 & 9+3+3 & 9+9+1 \end{bmatrix}$$

$$= \begin{bmatrix} 19 & 15 & 15 \\ 15 & 19 & 15 \\ 15 & 15 & 19 \end{bmatrix}$$

$$\therefore A^2 - 5A = \begin{bmatrix} 19 & 15 & 15 \\ 15 & 19 & 15 \\ 15 & 15 & 19 \end{bmatrix} - 5 \begin{bmatrix} 1 & 3 & 3 \\ 3 & 1 & 3 \\ 3 & 3 & 1 \end{bmatrix}$$

$$= \begin{bmatrix} 19 & 15 & 15 \\ 15 & 19 & 15 \\ 15 & 15 & 19 \end{bmatrix} - \begin{bmatrix} 5 & 15 & 15 \\ 15 & 5 & 15 \\ 15 & 15 & 5 \end{bmatrix}$$

$$\therefore A^2 - 5A = \begin{bmatrix} 14 & 0 & 0 \\ 0 & 14 & 0 \\ 0 & 0 & 14 \end{bmatrix} = 14I$$

$\therefore A^2 - 5A$  is a scalar matrix.

**Ex. 3 :** If  $A = \begin{bmatrix} 3 & -2 \\ 4 & -2 \end{bmatrix}$ , Find k, so that  $A^2 - kA + 2I = O$ , where I is an identity matrix and O is null matrix of order 2.

**Solution :** Given  $A^2 - kA + 2I = O$

$$\therefore \text{Here, } A^2 = AA = \begin{bmatrix} 3 & -2 \\ 4 & -2 \end{bmatrix} \begin{bmatrix} 3 & -2 \\ 4 & -2 \end{bmatrix}$$

$$= \begin{bmatrix} 9-8 & -6+4 \\ 12-8 & -8+4 \end{bmatrix} = \begin{bmatrix} 1 & -2 \\ 4 & -4 \end{bmatrix}$$

$$\therefore A^2 - kA + 2I = O$$

$$\therefore \begin{bmatrix} 1 & -2 \\ 4 & -4 \end{bmatrix} - k \begin{bmatrix} 3 & -2 \\ 4 & -2 \end{bmatrix} + 2 \begin{bmatrix} 1 & 0 \\ 0 & 1 \end{bmatrix} = O$$

$$\therefore \begin{bmatrix} 1 & -2 \\ 4 & -4 \end{bmatrix} - \begin{bmatrix} 3k & -2k \\ 4k & -2k \end{bmatrix} + \begin{bmatrix} 2 & 0 \\ 0 & 2 \end{bmatrix} = \begin{bmatrix} 0 & 0 \\ 0 & 0 \end{bmatrix}$$

$$\therefore \begin{bmatrix} 1-3k+2 & -2+2k \\ 4-4k & -4+2k+2 \end{bmatrix} = \begin{bmatrix} 0 & 0 \\ 0 & 0 \end{bmatrix}$$

$\therefore$  Using definition of equality of matrices, we have

$$\left. \begin{array}{ll} 1 - 3k + 2 = 0 & \therefore 3k = 3 \\ -2 + k = 0 & \therefore 2k = 2 \\ 4 - 4k = 0 & \therefore 4k = 4 \\ -4 + 2k + 2 = 0 & \therefore 2k = 2 \end{array} \right\} k = 1$$

**Ex. 4 :** Find x and y, if

$$[2 \ 0 \ 3] \left\{ 3 \begin{bmatrix} 6 & 3 \\ -1 & 2 \\ 5 & 4 \end{bmatrix} + 2 \begin{bmatrix} -4 & -1 \\ 1 & 0 \\ -3 & -4 \end{bmatrix} \right\} = [x \ y]$$

**Solution :**

$$\text{Given } [2 \ 0 \ 3] \left\{ 3 \begin{bmatrix} 6 & 3 \\ -1 & 2 \\ 5 & 4 \end{bmatrix} + 2 \begin{bmatrix} -4 & -1 \\ 1 & 0 \\ -3 & -4 \end{bmatrix} \right\} = [x \ y]$$

$$\therefore [2 \ 0 \ 3] \left\{ \begin{bmatrix} 18 & 9 \\ -3 & 6 \\ 15 & 12 \end{bmatrix} + \begin{bmatrix} -8 & -2 \\ 2 & 0 \\ -6 & -8 \end{bmatrix} \right\} = [x \ y]$$

$$\therefore [2 \ 0 \ 3] \begin{bmatrix} 10 & 7 \\ -1 & 6 \\ 9 & 4 \end{bmatrix} = [x \ y]$$

$$\therefore [20 + 27 \ 14 + 12] = [x \ y]$$

$\therefore [47 \ 26] = [x \ y] \therefore x = 47, y = 26$  by definition of equality of matrices.

**Ex. 5 :** Find if  $\begin{bmatrix} \sin\theta \\ \cos\theta \\ \theta \end{bmatrix} [\sin\theta \ \cos\theta \ \theta] = [17]$

**Solution :** Let  $\begin{bmatrix} \sin\theta \\ \cos\theta \\ \theta \end{bmatrix} [\sin\theta \ \cos\theta \ \theta] = [17],$

$$\therefore [\sin^2\theta + \cos^2\theta + \theta^2] = [17]$$

$\therefore$  By definition of equality of matrices

$$\therefore 1 + \theta^2 = 17 \quad \therefore \theta^2 = 17 - 1 \quad \therefore \theta^2 = 16,$$

$$\therefore \theta = \pm 4$$

**Remark**

Using the distributive laws discussed earlier we can derive the following results,

If A and B are square matrices of the same order, then

i)  $(A + B)^2 = A^2 + AB + BA + B^2$

ii)  $(A - B)^2 = A^2 - AB - BA + B^2$

iii)  $(A + B)(A - B) = A^2 + AB - BA - B^2$

**Ex. 6 :** If  $A = \begin{bmatrix} a & 0 \\ 0 & b \end{bmatrix}$ , prove that  $A^n = \begin{bmatrix} a^n & 0 \\ 0 & b^n \end{bmatrix}$  for all  $n \in \mathbb{N}$ .

**Solution :** Given  $A = \begin{bmatrix} a & 0 \\ 0 & b \end{bmatrix}$

We prove  $A^n = \begin{bmatrix} a^n & 0 \\ 0 & b^n \end{bmatrix}$  for all  $n \in \mathbb{N}$  using mathematical induction

Let P(n) be  $= \begin{bmatrix} a^n & 0 \\ 0 & b^n \end{bmatrix}$  for  $n \in \mathbb{N}$ .

To prove that P(n) is true for  $n=1$

P(1) is  $A^1 = A = \begin{bmatrix} a & 0 \\ 0 & b \end{bmatrix} \therefore$  P(1) is true.

Assume that P(K) is true for some  $K \in \mathbb{N}$

That is P(K) is  $A^K = \begin{bmatrix} a^K & 0 \\ 0 & b^K \end{bmatrix}$

To prove that  $P(K) \rightarrow P(K+1)$  is true consider L.H.S. of P(K+1)

That is  $A^{K+1}$

$$= A^K \cdot A$$

$$= \begin{bmatrix} a^K & 0 \\ 0 & b^K \end{bmatrix} \begin{bmatrix} a & 0 \\ 0 & b \end{bmatrix} = \begin{bmatrix} a^{K+1} + 0 & 0 + 0 \\ 0 + 0 & b^{K+1} + 0 \end{bmatrix}$$

$$= \begin{bmatrix} a^{K+1} & 0 \\ 0 & b^{K+1} \end{bmatrix} = \text{R.H.S of } P(K+1)$$

Hence P(K+1) is true.

$$\therefore P(K) \Rightarrow P(K+1) \text{ for all } K \in \mathbb{N}$$

Hence by principle of mathematical induction, the statement P(n) is true for all  $n \in \mathbb{N}$ .

That is P(n) is true  $\rightarrow$  P(2) is true  $\rightarrow$  P(3) is true and so on  $\rightarrow$  P(n) is true,  $n \in \mathbb{N}$ .

$$\therefore = A^n \begin{bmatrix} a^n & 0 \\ 0 & b^n \end{bmatrix} \text{ for all } n \in \mathbb{N}.$$

**Ex. 7 :** A school purchased 8 dozen Mathematics books, 7 dozen Physics books and 10 dozen Chemistry books, the prices are Rs.50, Rs.40 and Rs.60 per book respectively. Find the total amount that the book seller will receive from school authority using matrix multiplication.

**Solution :** Let A be the column matrix of books of different subjects and let B be the row matrix of prices of one book of each subject.

$$A = \begin{bmatrix} 8 \times 12 \\ 7 \times 12 \\ 10 \times 12 \end{bmatrix} = \begin{bmatrix} 96 \\ 84 \\ 120 \end{bmatrix} \quad B = [50 \ 40 \ 60]$$

∴ The total amount received by the bookseller is obtained by matrix BA.

$$\begin{aligned} \therefore BA &= [50 \ 40 \ 60] \begin{bmatrix} 96 \\ 84 \\ 120 \end{bmatrix} \\ &= [50 \times 96 + 40 \times 84 + 60 \times 120] \\ &= [4800 + 3360 + 7200] = [15360] \end{aligned}$$

Thus the amount received by the bookseller from the school is Rs.15360.

**Ex. 8 :** Some schools send their students for extra training in Kabaddi, Cricket and Tennis to a sports standidium. There center charge fee is changed pen student for Coaching as well as 4 equipment and maintenances of the court. The information of students from each school is given below-

	Kabaddi	Cricket	Tennis
Modern School			
Progressive School	20	35	15
Sharada Sadan	18	36	12
Vidya Niketan	24	12	8
	25	20	6

The charges per student for each game are given below-

	Kabaddi	Coach E & M
Cricket	40	10
Tennis	50	50
	60	40

E and M is for equipment and maintain

To find the expense of each school on Coaching and E and M can be found by multiplication of the above matrices.

	Kabaddi	Cricket	Tennis	Coach	E & M	
Modern	20	35	18	Kab	40	10
Progressive	18	36	12	X cri	50	50
Sharada School	24	12	8	Ten	60	40
Vidya Niketan	25	20	6			

$$\begin{array}{l} \text{Modern} \\ \text{Progressive} \\ \text{Sharada} \\ \text{Vidya} \end{array} \begin{bmatrix} 20 \times 40 + 36 \times 50 + 18 \times 60 & 20 \times 10 + 35 \times 50 + 18 \times 40 \\ 18 \times 40 + 36 \times 50 + 12 \times 60 & 18 \times 10 + 36 \times 50 + 12 \times 40 \\ 24 \times 40 + 12 \times 50 + 8 \times 60 & 24 \times 10 + 12 \times 50 + 8 \times 40 \\ 25 \times 40 + 20 \times 50 + 6 \times 60 & 25 \times 10 + 20 \times 50 + 6 \times 40 \end{bmatrix}$$

$$= \begin{bmatrix} 800 + 1750 + 108 & 200 + 1750 + 720 \\ 720 + 1800 + 720 & 180 + 1800 + 480 \\ 960 + 600 + 480 & 240 + 600 + 320 \\ 1000 + 1000 + 360 & 250 + 1000 + 240 \end{bmatrix} = \begin{bmatrix} 2650 & 2670 \\ 3240 & 2960 \\ 2040 & 1160 \\ 2360 & 1490 \end{bmatrix}$$

**EXERCISE 4.6**

1) Evaluate i)  $\begin{bmatrix} 3 \\ 2 \\ 1 \end{bmatrix} \begin{bmatrix} 2 & -4 & 3 \end{bmatrix}$  ii)  $\begin{bmatrix} 2 & -1 & 3 \end{bmatrix} \begin{bmatrix} 4 \\ 3 \\ 1 \end{bmatrix}$

2) If  $A = \begin{bmatrix} 1 & -3 \\ 4 & 2 \end{bmatrix}$ ,  $B = \begin{bmatrix} 4 & 1 \\ 3 & -2 \end{bmatrix}$  show that  $AB \neq BA$ .

3) If  $A = \begin{bmatrix} -1 & 1 & 1 \\ 2 & 3 & 0 \\ 1 & -3 & 1 \end{bmatrix}$ ,  $B = \begin{bmatrix} 2 & 1 & 4 \\ 3 & 0 & 2 \\ 1 & 2 & 1 \end{bmatrix}$ . State whether  $AB=BA$ ?

Justify your answer.

4) Show that  $AB=BA$  where,

i)  $A = \begin{bmatrix} -2 & 3 & -1 \\ -1 & 2 & -1 \\ -6 & 9 & -4 \end{bmatrix}$ ,  $B = \begin{bmatrix} 1 & 3 & -1 \\ 2 & 2 & -1 \\ 3 & 0 & -1 \end{bmatrix}$

ii)  $A = \begin{bmatrix} \cos\theta & \sin\theta \\ \sin\theta & \cos\theta \end{bmatrix}$ ,  $B = \begin{bmatrix} \cos\theta & -\sin\theta \\ \sin\theta & \cos\theta \end{bmatrix}$

5) If  $A = \begin{bmatrix} 4 & 8 \\ -2 & -4 \end{bmatrix}$ , prove that  $A^2 = 0$ .

6) Verify  $A(BC) = (AB)C$  in each of the following cases.

i)  $A = \begin{bmatrix} 1 & 0 & 1 \\ 2 & 3 & 0 \\ 0 & 4 & 5 \end{bmatrix}$ ,  $B = \begin{bmatrix} 2 & -2 \\ -1 & 1 \\ 0 & 3 \end{bmatrix}$  and

$C = \begin{bmatrix} 3 & 2 & -1 \\ 2 & 0 & -2 \end{bmatrix}$

ii)  $A = \begin{bmatrix} 2 & 4 & 3 \\ -1 & 3 & 2 \end{bmatrix}$ ,  $B = \begin{bmatrix} 2 & -2 \\ 3 & 3 \\ -1 & 1 \end{bmatrix}$  and

$C = \begin{bmatrix} 3 & 1 \\ 1 & 3 \end{bmatrix}$ .

7) Verify that  $A(B+C)=AB+BC$  in each of the following matrices

i)  $A = \begin{bmatrix} 4 & -2 \\ 2 & 3 \end{bmatrix}$ ,  $B = \begin{bmatrix} -1 & 1 \\ 3 & -2 \end{bmatrix}$  and

$C = \begin{bmatrix} 4 & 1 \\ 2 & -1 \end{bmatrix}$

ii)  $A = \begin{bmatrix} 1 & -1 & 3 \\ 2 & 3 & 2 \end{bmatrix}$ ,  $B = \begin{bmatrix} 1 & 0 \\ -2 & 3 \\ 4 & 3 \end{bmatrix}$  and

$C = \begin{bmatrix} 1 & 2 \\ -2 & 0 \\ 4 & -3 \end{bmatrix}$

8) If  $A = \begin{bmatrix} 1 & -2 \\ 5 & 6 \end{bmatrix}$ ,  $B = \begin{bmatrix} 3 & -1 \\ 3 & 7 \end{bmatrix}$ ,

Find  $AB-2I$ , where  $I$  is unit matrix of order 2.

9) If  $A = \begin{bmatrix} 4 & 3 & 2 \\ -1 & 2 & 0 \end{bmatrix}$ ,  $B = \begin{bmatrix} 1 & 2 \\ -1 & 0 \\ 1 & -2 \end{bmatrix}$  show

that matrix  $AB$  is non singular.

10) If  $A = \begin{bmatrix} 1 & 2 & 0 \\ 5 & 4 & 2 \\ 0 & 7 & -3 \end{bmatrix}$ , find the product  $(A+I)(A-I)$ .

11)  $A = \begin{bmatrix} \alpha & 0 \\ 1 & 1 \end{bmatrix}$ ,  $B = \begin{bmatrix} 1 & 0 \\ 2 & 1 \end{bmatrix}$  find  $\alpha$ , if  $A^2 = B$ .

12) If  $A = \begin{bmatrix} 1 & 2 & 2 \\ 2 & 1 & 2 \\ 2 & 2 & 1 \end{bmatrix}$ , Show that  $A^2 - 4A$  is a scalar matrix.

13) If  $A = \begin{bmatrix} 1 & 0 \\ -1 & 7 \end{bmatrix}$ , find  $k$  so that  $A^2 - 8A - kI = O$ , where  $I$  is a unit matrix and  $O$  is a null matrix of order 2.

14) If  $A = \begin{bmatrix} 8 & 4 \\ 10 & 5 \end{bmatrix}$ ,  $B = \begin{bmatrix} 5 & -4 \\ 10 & -8 \end{bmatrix}$  show that  $(A + B)^2 = A^2 + AB + B^2$ .

15) If  $A = \begin{bmatrix} 3 & 1 \\ -1 & 2 \end{bmatrix}$ , prove that  $A^2 - 5A + 7I = 0$ , where  $I$  is unit matrix of order 2.

16) If  $A = \begin{bmatrix} 3 & 4 \\ -4 & 3 \end{bmatrix}$  and  $B = \begin{bmatrix} 2 & 1 \\ -1 & 2 \end{bmatrix}$ , show that  $(A+B)(A-B) = A^2 - B^2$ .

17) If  $A = \begin{bmatrix} 1 & 2 \\ -1 & -2 \end{bmatrix}$ ,  $B = \begin{bmatrix} 2 & a \\ -1 & b \end{bmatrix}$  and if  $(A + B)^2 = A^2 - B^2$ . find values of  $a$  and  $b$ .

18) Find matrix  $X$  such that  $AX = B$ , where

$$A = \begin{bmatrix} 1 & -2 \\ -2 & 1 \end{bmatrix} \text{ and } B = \begin{bmatrix} -3 \\ -1 \end{bmatrix}.$$

19) Find  $k$ , if  $A = \begin{bmatrix} 3 & -2 \\ 4 & -2 \end{bmatrix}$  and if  $A^2 = kA - 2I$ .

20) Find  $x$ , if  $\begin{bmatrix} 1 & x & 1 \\ 4 & 5 & 6 \\ 3 & 2 & 5 \end{bmatrix} \begin{bmatrix} 1 \\ -2 \\ 3 \end{bmatrix} = 0$ .

21) Find  $x$  and  $y$ , if

$$\left\{ 4 \begin{bmatrix} 2 & -1 & 3 \\ 1 & 0 & 2 \end{bmatrix} - \begin{bmatrix} 3 & -3 & 4 \\ 2 & 1 & 1 \end{bmatrix} \right\} \begin{bmatrix} 2 \\ -1 \\ 1 \end{bmatrix} = \begin{bmatrix} x \\ y \end{bmatrix}$$

22) Find  $x, y, z$  if

$$\left\{ 3 \begin{bmatrix} 2 & 0 \\ 0 & 2 \\ 2 & 2 \end{bmatrix} - 4 \begin{bmatrix} 1 & 1 \\ -1 & 2 \\ 3 & 1 \end{bmatrix} \right\} \begin{bmatrix} 1 \\ 2 \end{bmatrix} = \begin{bmatrix} x-3 \\ y-1 \\ 2z \end{bmatrix}.$$

23) If  $A = \begin{bmatrix} \cos\alpha & \sin\alpha \\ -\sin\alpha & \cos\alpha \end{bmatrix}$ , show that

$$A^2 = \begin{bmatrix} \cos 2\alpha & \sin 2\alpha \\ -\sin 2\alpha & \cos 2\alpha \end{bmatrix}.$$

24) If  $A = \begin{bmatrix} 1 & 2 \\ 3 & 5 \end{bmatrix}$ ,  $B = \begin{bmatrix} 0 & 4 \\ 2 & -1 \end{bmatrix}$ , show that

$$AB \neq BA, \text{ but } |AB| = |A| \cdot |B|$$

25) Jay and Ram are two friends in a class. Jay wanted to buy 4 pens and 8 notebooks, Ram wanted to buy 5 pens and 12 notebooks. Both of them went to a shop. The price of a pen and a notebook which they have selected was Rs.6 and Rs.10. Using Matrix multiplication, find the amount required from each one of them.

#### 4.7 Properties of transpose of a matrix :

##### Note :

- (1) For any matrix  $A$ ,  $(A^T)^T = A$ .
- (2) If  $A$  is a matrix and  $k$  is constant, then  $(kA)^T = kA^T$ .
- (3) If  $A$  and  $B$  are two matrices of same order, then  $(A + B)^T = A^T + B^T$ .
- (4) If  $A$  and  $B$  are conformable for the product  $AB$ , then  $(AB)^T = B^T A^T$ .

Example, Let  $A = \begin{bmatrix} 1 & 2 & 1 \\ 3 & 1 & 3 \end{bmatrix}$ ,  $B = \begin{bmatrix} 2 & 3 \\ 1 & 2 \\ 1 & 2 \end{bmatrix}$ ,

∴ AB is defined and

$$AB = \begin{bmatrix} 2+2+1 & 3+4+2 \\ 6+1+3 & 9+2+6 \end{bmatrix} = \begin{bmatrix} 5 & 9 \\ 10 & 17 \end{bmatrix},$$

$$\therefore (AB)^T = \begin{bmatrix} 5 & 10 \\ 9 & 17 \end{bmatrix} \dots\dots\dots (1)$$

$$\text{Now } A^T = \begin{bmatrix} 1 & 3 \\ 2 & 1 \\ 1 & 3 \end{bmatrix}, B^T = \begin{bmatrix} 2 & 1 & 1 \\ 3 & 2 & 2 \end{bmatrix},$$

$$\therefore B^T A^T = \begin{bmatrix} 2 & 1 & 1 \\ 3 & 2 & 2 \end{bmatrix} \begin{bmatrix} 1 & 3 \\ 2 & 1 \\ 1 & 3 \end{bmatrix}$$

$$\begin{aligned} \therefore B^T A^T &= \begin{bmatrix} 2+2+1 & 6+1+3 \\ 3+4+2 & 9+2+6 \end{bmatrix} \\ &= \begin{bmatrix} 5 & 10 \\ 9 & 17 \end{bmatrix} \dots\dots\dots (2) \end{aligned}$$

∴ From (1) and (2) we have,  $(AB)^T = B^T A^T$

In general  $(A_1 A_2 A_3, \dots, A_n)^T = A_n^T \dots A_3^T A_2^T A_1^T$

(5) If A is a symmetric matrix, then  $A^T = A$ .

For example, let  $A = \begin{bmatrix} 2 & -3 & 4 \\ -3 & 5 & -2 \\ 4 & -2 & 1 \end{bmatrix}$

$$A^T = \begin{bmatrix} 2 & -3 & 4 \\ -3 & 5 & -2 \\ 4 & -2 & 1 \end{bmatrix} = A$$

(6) If A is a skew symmetric matrix, then  $A^T = -A$ .

For example, let  $A = \begin{bmatrix} 0 & 5 & 4 \\ -5 & 0 & -2 \\ -4 & 2 & 0 \end{bmatrix}$

$$\begin{aligned} \therefore A^T &= \begin{bmatrix} 0 & -5 & -4 \\ 5 & 0 & 2 \\ 4 & -2 & 0 \end{bmatrix} = - \begin{bmatrix} 0 & 5 & 4 \\ -5 & 0 & -2 \\ -4 & 2 & 0 \end{bmatrix} \\ &= -A, \therefore A^T = -A \end{aligned}$$

(7) If A is a square matrix, then (a)  $A + A^T$  is symmetric. (b)  $A - A^T$  is skew symmetric.

For example, (a) Let  $A = \begin{bmatrix} 3 & 5 & 7 \\ 2 & 4 & -6 \\ 3 & 8 & -5 \end{bmatrix},$

$$\therefore A^T = \begin{bmatrix} 3 & 2 & 3 \\ 5 & 4 & 8 \\ 7 & -6 & -5 \end{bmatrix}$$

$$\begin{aligned} \text{Now } A + A^T &= \begin{bmatrix} 3 & 5 & 7 \\ 2 & 4 & -6 \\ 3 & 8 & -5 \end{bmatrix} + \begin{bmatrix} 3 & 2 & 3 \\ 5 & 4 & 8 \\ 7 & -6 & -5 \end{bmatrix} \\ &= \begin{bmatrix} 6 & 7 & 10 \\ 7 & 8 & 2 \\ 10 & 2 & -10 \end{bmatrix} \end{aligned}$$

∴  $A + A^T$  is a symmetric matrix, by definition.

(b) Let  $A - A^T = \begin{bmatrix} 3 & 5 & 7 \\ 2 & 4 & -6 \\ 3 & 8 & -5 \end{bmatrix} - \begin{bmatrix} 3 & 2 & 3 \\ 5 & 4 & 8 \\ 7 & -6 & -5 \end{bmatrix}$

$$= \begin{bmatrix} 0 & 3 & 4 \\ -3 & 0 & -14 \\ -4 & 14 & 0 \end{bmatrix}$$

$A - A^T$  is a skew symmetric matrix, by definition.

**Note:**

A square matrix A can be expressed as the sum of a symmetric and a skew symmetric matrix as  $A = \frac{1}{2}(A + A^T) + \frac{1}{2}(A - A^T)$

e.g. Let  $A = \begin{bmatrix} 4 & -5 & 3 \\ -6 & 2 & 1 \\ 7 & 8 & -9 \end{bmatrix},$

$$\therefore A^T = \begin{bmatrix} 4 & -6 & 7 \\ -5 & 2 & 8 \\ 3 & 1 & -9 \end{bmatrix}$$

**EXERCISE 4.7**

$$A + A^T = \begin{bmatrix} 4 & -5 & 3 \\ -6 & 2 & 1 \\ 7 & 8 & -9 \end{bmatrix} + \begin{bmatrix} 4 & -6 & 7 \\ -5 & 2 & 8 \\ 3 & 1 & -9 \end{bmatrix}$$

$$= \begin{bmatrix} 8 & -11 & 10 \\ -11 & 4 & 9 \\ 10 & 9 & -18 \end{bmatrix}$$

$$\text{Let } P = \frac{1}{2} (A + A^T) = \frac{1}{2} \begin{bmatrix} 8 & -11 & 10 \\ -11 & 4 & 9 \\ 10 & 9 & -18 \end{bmatrix}$$

$$= \begin{bmatrix} 4 & -\frac{11}{2} & 5 \\ -\frac{11}{2} & 2 & \frac{9}{2} \\ 5 & \frac{9}{2} & -9 \end{bmatrix}$$

The matrix P is a symmetric matrix.

$$\text{Also } A - A^T = \begin{bmatrix} 4 & -5 & 3 \\ -6 & 2 & 1 \\ 7 & 8 & -9 \end{bmatrix} - \begin{bmatrix} 4 & -6 & 7 \\ -5 & 2 & 8 \\ 3 & 1 & -9 \end{bmatrix}$$

$$= \begin{bmatrix} 0 & 1 & -4 \\ -1 & 0 & -7 \\ 4 & 7 & 0 \end{bmatrix}$$

$$\text{Let } Q = \frac{1}{2} (A - A^T) = \frac{1}{2} \begin{bmatrix} 0 & 1 & -4 \\ -1 & 0 & -7 \\ 4 & 7 & 0 \end{bmatrix}$$

$$= \begin{bmatrix} 0 & \frac{1}{2} & -2 \\ -\frac{1}{2} & 0 & -\frac{7}{2} \\ 2 & \frac{7}{2} & 0 \end{bmatrix}$$

The matrix Q is a skew symmetric matrix.

Since  $P+Q$  = symmetric matrix + skew symmetric matrix.

Thus  $A = P + Q$ .

(1) Find  $A^T$ , if (i)  $A = \begin{bmatrix} 1 & 3 \\ -4 & 5 \end{bmatrix}$

(ii)  $A = \begin{bmatrix} 2 & -6 & 1 \\ -4 & 0 & 5 \end{bmatrix}$

(2) If  $[a_{ij}]_{3 \times 3}$  where  $a_{ij} = 2(i-j)$ . Find A and  $A^T$ . State whether A and  $A^T$  are symmetric or skew symmetric matrices?

(3) If  $A = \begin{bmatrix} 5 & -3 \\ 4 & -3 \\ -2 & 1 \end{bmatrix}$ , Prove that  $(2A)^T = 2A^T$ .

(4) If  $A = \begin{bmatrix} 1 & 2 & -5 \\ 2 & -3 & 4 \\ -5 & 4 & 9 \end{bmatrix}$ , Prove that  $(3A)^T = 3A^T$ .

(5) If  $A = \begin{bmatrix} 0 & 1+2i & i-2 \\ -1-2i & 0 & -7 \\ 2-i & 7 & 0 \end{bmatrix}$

where  $i = \sqrt{-1}$ , Prove that  $A^T = -A$ .

(6) If  $A = \begin{bmatrix} 2 & -3 \\ 5 & -4 \\ -6 & 1 \end{bmatrix}$ ,  $B = \begin{bmatrix} 2 & 1 \\ 4 & -1 \\ -3 & 3 \end{bmatrix}$  and

$C = \begin{bmatrix} 1 & 2 \\ -1 & 4 \\ -2 & 3 \end{bmatrix}$  then show that

(i)  $(A + B) = A^T + B^T$  (ii)  $(A - C)^T = A^T - C^T$

(7) If  $A = \begin{bmatrix} 5 & 4 \\ -2 & 3 \end{bmatrix}$  and  $B = \begin{bmatrix} -1 & 3 \\ 4 & -1 \end{bmatrix}$ , then find

$C^T$ , such that  $3A - 2B + C = I$ , where I is the unit matrix of order 2.

(8) If  $A = \begin{bmatrix} 7 & 3 & 0 \\ 0 & 4 & -2 \end{bmatrix}$ ,  $B = \begin{bmatrix} 0 & -2 & 3 \\ 2 & 1 & -4 \end{bmatrix}$  then

find (i)  $A^T + 4B^T$  (ii)  $5A^T - 5B^T$ .

(9) If  $A = \begin{bmatrix} 1 & 0 & 1 \\ 3 & 1 & 2 \end{bmatrix}$ ,  $B = \begin{bmatrix} 2 & 1 & -4 \\ 3 & 5 & -2 \end{bmatrix}$  and

$C = \begin{bmatrix} 0 & 2 & 3 \\ -1 & -1 & 0 \end{bmatrix}$ , verify that

$(A + 2B + 2C)^T = A^T + 2B^T + 3C^T$ .

(10) If  $A = \begin{bmatrix} -1 & 2 & 1 \\ -3 & 2 & -3 \end{bmatrix}$  and  $B = \begin{bmatrix} 2 & 1 \\ -3 & 2 \\ -1 & 3 \end{bmatrix}$ , prove

that  $(A + B^T)^T = A^T + B$ .

(11) Prove that  $A + A^T$  is a symmetric and  $A - A^T$  is a skew symmetric matrix, where

(i)  $A = \begin{bmatrix} 1 & 2 & 4 \\ 3 & 2 & 1 \\ -2 & -3 & 2 \end{bmatrix}$  (ii)  $A = \begin{bmatrix} 5 & 2 & -4 \\ 3 & -7 & 2 \\ 4 & -5 & -3 \end{bmatrix}$

(12) Express the following matrices as the sum of a symmetric and a skew symmetric matrix.

(i)  $\begin{bmatrix} 4 & -2 \\ 3 & -5 \end{bmatrix}$  (ii)  $\begin{bmatrix} 3 & 3 & -1 \\ -2 & -2 & 1 \\ -4 & -5 & 2 \end{bmatrix}$

(13) If  $A = \begin{bmatrix} 2 & -1 \\ 3 & -2 \\ 4 & 1 \end{bmatrix}$  and  $B = \begin{bmatrix} 0 & 3 & -4 \\ 2 & -1 & 1 \end{bmatrix}$ ,

verify that (i)  $(AB)^T = B^T A^T$

(ii)  $(BA)^T = A^T B^T$

(14) If  $A = \begin{bmatrix} \cos\alpha & \sin\alpha \\ -\sin\alpha & \cos\alpha \end{bmatrix}$ , show that  $A^T A = I$ ,

where  $I$  is the unit matrix of order 2.



### Let's Remember

- The value of a determinant of order  $3 \times 3$

$$\begin{vmatrix} a_1 & b_1 & c_1 \\ a_2 & b_2 & c_2 \\ a_3 & b_3 & c_3 \end{vmatrix} = a_1(b_2c_3 - b_3c_2) - b_1(a_2c_3 - a_3c_2) + c_1(a_2b_3 - a_3b_2)$$

- The minors and cofactors of elements of a determinant

$$\Delta = \begin{vmatrix} a_{11} & a_{12} & a_{13} \\ a_{21} & a_{22} & a_{23} \\ a_{31} & a_{32} & a_{33} \end{vmatrix}$$

Minor  $M_{ij}$  of the element  $a_{ij}$  is determinant obtained by deleting the  $i^{\text{th}}$  row and  $j^{\text{th}}$  column of determinant  $D$ . The cofactor  $C_{ij}$  of element  $a_{ij}$  is  $C_{ij} = (-1)^{i+j} M_{ij}$

- Properties of determinant**

**Property (i)** - The value of determinant remains unchanged if its rows are turned into columns and columns are turned into rows.

**Property (ii)** - If any two rows (or columns) of the determinant are interchanged then the value of determinant changes its sign.

**Property (iii)** - If any two rows (or columns) of a determinant are identical then the value of determinant is zero

**Property (iv)** - If any element of a row (or column) of determinant is multiplied by a constant  $k$  then the value of the new determinant is  $k$  times the value of old determinant

**Property (v)** - If each element of a row (or column) is expressed as the sum of two numbers then the determinant can be expressed as sum of two determinants

**Property (vi)** - If a constant multiple of all elements of a row (or column) is added to the corresponding elements of any other row (or column) then the value of new determinant so obtained is the same as that of the original determinant.

**Property (vii)** - (Triangle property) - If each element of a determinant above or below the main diagonal is zero then the value of the determinant is equal to the product of its diagonal elements.

- A system of linear equations, using Cramer's Rule has solution -

$$x = \frac{D_x}{D}, y = \frac{D_y}{D}, z = \frac{D_z}{D}; \text{ provided } D \neq 0$$

- Consistency of three equations.

$$a_1x + b_1y + c_1 = 0$$

$$a_2x + b_2y + c_2 = 0$$

$$a_3x + b_3y + c_3 = 0 \text{ are consistent}$$

$$\text{Then } \begin{vmatrix} a_1 & b_1 & c_1 \\ a_2 & b_2 & c_2 \\ a_3 & b_3 & c_3 \end{vmatrix} = 0$$

- Area of triangle whose vertices are  $(x_1, y_1)$ ,  $(x_2, y_2)$ ,  $(x_3, y_3)$  is

$$A(\Delta) = \frac{1}{2} \begin{vmatrix} x_1 & y_1 & 1 \\ x_2 & y_2 & 1 \\ x_3 & y_3 & 1 \end{vmatrix}$$

- Test for collinear of points  $(x_1, y_1)$ ,  $(x_2, y_2)$ ,

$$(x_3, y_3) \text{ if } \begin{vmatrix} x_1 & y_1 & 1 \\ x_2 & y_2 & 1 \\ x_3 & y_3 & 1 \end{vmatrix} = 0$$

- **Multiplication of a matrix by a scalar:**

If A  $[a_{ij}]$  is a matrix and k is a scalar, then  $kA = [ka_{ij}]$ .

- **Addition of matrices:**

Matrices  $A = [a_{ij}]$  and  $B = [b_{ij}]$  are said to conformable for addition if orders of A and B are same.

$A+B = [a_{ij} + b_{ij}]$ . The order of A+B is the same as that of A and B.

- **Multiplication of two matrices:**

A and B are said to be conformable for the multiplication if number of columns of A is equal to the number of rows of B.

That is If  $A = [a_{ik}]_{m \times p}$  and  $B = [b_{kj}]_{p \times n}$ , then AB is defined and  $AB = [c_{ij}]_{m \times n}$  where

$$c_{ij} = \sum_{k=1}^n a_{ik} \cdot b_{kj} \quad \begin{matrix} i = 1, 2, \dots, m \\ j = 1, 2, \dots, n. \end{matrix}$$

- If  $A = [a_{ij}]_{m \times n}$  is any matrix, then the transpose of A is denoted by  $A^T = B = [b_{ij}]_{m \times n}$  and  $b_{ji} = a_{ij}$
- If A is a square matrix, then

i)  $A + A^T$  is a symmetric matrix.

ii)  $A - A^T$  is a skew-symmetric matrix.

- Every square matrix A can be expressed as the sum of a symmetric and skew-symmetric matrix as

$$A = \frac{1}{2} [A + A^T] + \frac{1}{2} [A - A^T].$$

**MISCELLANEOUS EXERCISE - 4 (B)**

- (I) **Select the correct option from the given alternatives.**

1) Given  $A = \begin{bmatrix} 1 & 3 \\ 2 & 2 \end{bmatrix}$ ,  $I = \begin{bmatrix} 1 & 0 \\ 0 & 1 \end{bmatrix}$  if  $A - \lambda I$  is a

singular matrix then .....

A)  $\lambda = 0$                       B)  $\lambda^2 - 3\lambda - 4 = 0$

C)  $\lambda^2 + 3 - 4 = 0$               D)  $\lambda^2 - 3\lambda - 6 = 0$

2) Consider the matrices  $A = \begin{bmatrix} 4 & 6 & -1 \\ 3 & 0 & 2 \\ 1 & -2 & 5 \end{bmatrix}$ ,

$B = \begin{bmatrix} 2 & 4 \\ 0 & 1 \\ -1 & 2 \end{bmatrix}$ ,  $C = \begin{bmatrix} 3 \\ 1 \\ 2 \end{bmatrix}$  out of the given

matrix product .....

- i)  $(AB)^T C$                       ii)  $C^T C (AB)^T$   
 iii)  $C^T AB$                       iv)  $A^T A B B^T C$

- A) Exactly one is defined  
 B) Exactly two are defined  
 C) Exactly three are defined  
 D) all four are defined

3) If A and B are square matrices of equal order, then which one is correct among the following?

- A)  $A + B = B + A$               B)  $A + B = A - B$   
 C)  $A - B = B - A$               D)  $AB = BA$

4) If  $A = \begin{bmatrix} 1 & 2 & 2 \\ 2 & 1 & -2 \\ a & 2 & b \end{bmatrix}$  is a matrix satisfying the

equation  $AA^T = 9I$ , where I is the identity matrix of order 3, then the ordered pair (a, b) is equal to .....

- A) (2, -1)                      B) (-2, 1)  
 C) (2, 1)                      D) (-2, -1)

5) If  $A = \begin{bmatrix} \alpha & 2 \\ 2 & \alpha \end{bmatrix}$  and  $|A^3| = 125$ ,

then  $\alpha = \dots\dots$

- A)  $\pm 3$               B)  $\pm 2$               C)  $\pm 5$               D) 0

6) If  $\begin{bmatrix} 5 & 7 \\ x & 1 \\ 2 & 6 \end{bmatrix} - \begin{bmatrix} 1 & 2 \\ -3 & 5 \\ 2 & y \end{bmatrix} = \begin{bmatrix} 4 & 5 \\ 4 & -4 \\ 0 & 4 \end{bmatrix}$  then .....

- A)  $x = 1, y = -2$               B)  $x = -1, y = 2$   
 C)  $x = 1, y = 2$               D)  $x = -1, y = -2$

7) If  $A + B = \begin{bmatrix} 7 & 4 \\ 8 & 9 \end{bmatrix}$  and  $A - B = \begin{bmatrix} 1 & 2 \\ 0 & 3 \end{bmatrix}$

then the value of A is .....

- A)  $\begin{bmatrix} 3 & 1 \\ 4 & 3 \end{bmatrix}$                       B)  $\begin{bmatrix} 4 & 3 \\ 4 & 6 \end{bmatrix}$   
 C)  $\begin{bmatrix} 6 & 2 \\ 8 & 6 \end{bmatrix}$                       D)  $\begin{bmatrix} 7 & 6 \\ 8 & 12 \end{bmatrix}$

8) If  $\begin{bmatrix} x & 3x - y \\ zx + z & 3y - w \end{bmatrix} = \begin{bmatrix} 3 & 2 \\ 4 & 7 \end{bmatrix}$  then .....

- a)  $x = 3, y = 7, z = 1, w = 14$   
 a)  $x = 3, y = -5, z = -1, w = -4$   
 a)  $x = 3, y = 6, z = 2, w = 7$   
 a)  $x = -3, y = -7, z = -1, w = -14$

9) For suitable matrices A, B, the false statement is .....

- A)  $(AB)^T = A^T B^T$   
 B)  $(A^T)^T = A$   
 C)  $(A - B)^T = A^T - B^T$   
 D)  $(A + B)^T = A^T + B^T$

10) If  $A = \begin{bmatrix} -2 & 1 \\ 0 & 3 \end{bmatrix}$  and  $f(x) = 2x^2 - 3x$ , then

$f(A) = \dots\dots\dots$

- A)  $\begin{bmatrix} 14 & 1 \\ 0 & -9 \end{bmatrix}$                       B)  $\begin{bmatrix} -14 & 1 \\ 0 & 9 \end{bmatrix}$   
 C)  $\begin{bmatrix} 14 & -1 \\ 0 & 9 \end{bmatrix}$                       D)  $\begin{bmatrix} -14 & -1 \\ 0 & -9 \end{bmatrix}$

**(II) Answer the following question.**

- 1) If  $A = \text{diag} [2 \ -3 \ -5]$ ,  $B = \text{diag} [4 \ -6 \ -3]$  and  $C = \text{diag} [-3 \ 4 \ 1]$  then find i)  $B + C - A$  ii)  $2A + B - 5C$ .

2) If  $f(\alpha) = A = \begin{bmatrix} \cos\alpha & -\sin\alpha & 0 \\ \sin\alpha & \cos\alpha & 0 \\ 0 & 0 & 1 \end{bmatrix}$ , Find

i)  $f(-\alpha)$  ii)  $f(-\alpha) + f(\alpha)$ .

3) Find matrices A and B, where i)

i)  $2A - B = \begin{bmatrix} 1 & -1 \\ 0 & 1 \end{bmatrix}$  and  $A + 3B = \begin{bmatrix} 1 & -1 \\ 0 & 1 \end{bmatrix}$

ii)  $3A - B = \begin{bmatrix} -1 & 2 & 1 \\ 1 & 0 & 5 \end{bmatrix}$  and

$$A + 5B = \begin{bmatrix} 0 & 0 & 1 \\ -1 & 0 & 0 \end{bmatrix}$$

4) If  $A = \begin{bmatrix} 2 & -3 \\ 3 & -2 \\ -1 & 4 \end{bmatrix}$ ,  $B = \begin{bmatrix} -3 & 4 & 1 \\ 2 & -1 & -3 \end{bmatrix}$

Verify i)  $(A + B^T)^T = A^T + 2B$ .

ii)  $(3A + 5B^T)^T = 3A^T - 5B$ .

5) If  $A = \begin{bmatrix} \cos\alpha & -\sin\alpha \\ \sin\alpha & \cos\alpha \end{bmatrix}$  and  $A + A^T = I$ , where

I is unit matrix  $2 \times 2$ , then find the value of  $\alpha$ .

6) If  $A = \begin{bmatrix} 1 & 2 \\ 3 & 2 \\ -1 & 0 \end{bmatrix}$  and  $B = \begin{bmatrix} 1 & 3 & 2 \\ 4 & -1 & -3 \end{bmatrix}$ , show

that AB is singular.

7) If  $A = \begin{bmatrix} 1 & 2 & 3 \\ 2 & 4 & 6 \\ 1 & 2 & 3 \end{bmatrix}$ ,  $B = \begin{bmatrix} 1 & -1 & 1 \\ -3 & 2 & -1 \\ -2 & 1 & 0 \end{bmatrix}$ , show

that AB and BA are both singular matrices.

8) If  $A = \begin{bmatrix} 1 & -1 & 0 \\ 2 & 3 & 4 \\ 0 & 1 & 2 \end{bmatrix}$ ,  $B = \begin{bmatrix} 2 & 2 & -4 \\ -4 & 2 & -4 \\ 2 & -1 & 5 \end{bmatrix}$ ,

show that  $BA = 6I$ .

9) If  $A = \begin{bmatrix} 2 & 1 \\ 0 & 3 \end{bmatrix}$ ,  $B = \begin{bmatrix} 1 & 2 \\ 3 & -2 \end{bmatrix}$ , verify that

$$|AB| = |A||B|.$$

10) If  $A = \begin{bmatrix} \cos\alpha & \sin\alpha \\ -\sin\alpha & \cos\alpha \end{bmatrix}$ ,

show that  $A_\alpha \cdot A_\beta = A_{\alpha+\beta}$ .

11) If  $A = \begin{bmatrix} 1 & \omega \\ \omega^2 & 1 \end{bmatrix}$ ,  $B = \begin{bmatrix} \omega^2 & 1 \\ 1 & \omega \end{bmatrix}$ , where  $\omega$  is

a complex cube root of unity, then show that  $AB + BA + A - 2B$  is a null matrix.

12) If  $A = \begin{bmatrix} 2 & -2 & -4 \\ -1 & 3 & 4 \\ 1 & -2 & -3 \end{bmatrix}$  show that  $A^2 = A$ .

13) If  $A = \begin{bmatrix} 4 & -1 & -4 \\ 3 & 0 & -4 \\ 3 & -1 & -1 \end{bmatrix}$ , show that  $A^2 = I$ .

14) If  $A = \begin{bmatrix} 3 & -5 \\ -4 & 2 \end{bmatrix}$ , show that  $A^2 - 5A - 14I = 0$ .

15) If  $A = \begin{bmatrix} 2 & -1 \\ -1 & 2 \end{bmatrix}$ , show that  $A^2 - 4A + 3I = 0$ .

16) If  $A = \begin{bmatrix} -3 & 2 \\ 2 & -4 \end{bmatrix}$ ,  $B = \begin{bmatrix} 1 & x \\ y & 0 \end{bmatrix}$ , and

$(A + B)(A - B) = A^2 - B^2$ , find  $x$  and  $y$ .

17) If  $A = \begin{bmatrix} 0 & 1 \\ 1 & 0 \end{bmatrix}$  and  $B = \begin{bmatrix} 0 & -1 \\ 1 & 0 \end{bmatrix}$  show that  
 $(A + B)(A - B) \neq A^2 - B^2$ .

18) If  $A = \begin{bmatrix} 2 & -1 \\ 3 & -2 \end{bmatrix}$ , find  $A^3$ .

19) Find  $x, y$  if,

i)  $[0 \ -1 \ 4] \left\{ 2 \begin{bmatrix} 4 & 5 \\ 3 & 6 \\ 2 & -1 \end{bmatrix} + 3 \begin{bmatrix} 4 & 3 \\ 1 & 4 \\ 0 & -1 \end{bmatrix} \right\}$   
 $= [x \ y]$ .

ii)  $\left\{ -1 \begin{bmatrix} 1 & 2 & 1 \\ 2 & 0 & 3 \end{bmatrix} + 3 \begin{bmatrix} 2 & -3 & 7 \\ 1 & -1 & 3 \end{bmatrix} \right\} \begin{bmatrix} 5 \\ 0 \\ -1 \end{bmatrix} = \begin{bmatrix} x \\ y \end{bmatrix}$

20) Find  $x, y, z$  if

i)  $\left\{ 5 \begin{bmatrix} 0 & 1 \\ 1 & 0 \\ 1 & 1 \end{bmatrix} - 3 \begin{bmatrix} 2 & 1 \\ 3 & -2 \\ 1 & 3 \end{bmatrix} \right\} \begin{bmatrix} 2 \\ 1 \end{bmatrix} = \begin{bmatrix} x-1 \\ y+1 \\ 2z \end{bmatrix}$

ii)  $\left\{ \begin{bmatrix} 1 & 3 & 2 \\ 2 & 0 & 1 \\ 3 & 1 & 2 \end{bmatrix} + 2 \begin{bmatrix} 3 & 0 & 2 \\ 1 & 4 & 5 \\ 2 & 1 & 0 \end{bmatrix} \right\} \begin{bmatrix} 1 \\ 2 \\ 3 \end{bmatrix} = \begin{bmatrix} x \\ y \\ z \end{bmatrix}$

21) If  $A = \begin{bmatrix} 2 & 1 & -3 \\ 0 & 2 & 6 \end{bmatrix}$ ,  $B = \begin{bmatrix} 1 & 0 & -2 \\ 3 & -1 & 4 \end{bmatrix}$ ,  
 find  $AB^T$  and  $A^T B$ .

22) If  $A = \begin{bmatrix} 2 & -4 \\ 3 & -2 \\ 0 & 1 \end{bmatrix}$ ,  $B = \begin{bmatrix} 1 & -1 & 2 \\ -2 & 1 & 0 \end{bmatrix}$ ,  
 show that  $(AB)^T = B^T A^T$ .

23) If  $A = \begin{bmatrix} 3 & -4 \\ 1 & -1 \end{bmatrix}$ , prove that

$$A^n = \begin{bmatrix} 1+2n & -4n \\ n & 1-2n \end{bmatrix}, \text{ for all } n \in \mathbb{N}.$$

24) If  $A = \begin{bmatrix} \cos\theta & \sin\theta \\ -\sin\theta & \cos\theta \end{bmatrix}$ , prove that

$$A^n = \begin{bmatrix} \cos n\theta & \sin n\theta \\ -\sin n\theta & \cos n\theta \end{bmatrix}, \text{ for all } n \in \mathbb{N}.$$

25) Two farmers Shantaram and Kantaram cultivate three crops rice, wheat and groundnut. The sale (In Rupees) of these crops by both the farmers for the month of April and May 2008 is given below,

April sale (In Rs.)

	Rice	Wheat	Groundnut
Shantaram	15000	13000	12000
Kantaram	18000	15000	8000

May sale (In Rs.)

	Rice	Wheat	Groundnut
Shantaram	18000	15000	12000
Kantaram	21000	16500	16000

Find

- The total sale in rupees for two months of each farmer for each crop.
- the increase in sale from April to May for every crop of each farmer.



# 5 Straight Line

## Let's Study

- Locus of a points in a co-ordinate plane
- Equations of line in different forms
- Angle between two lines, perpendicular and parallel lines
- Distance of a point from a line
- Family of lines

## Let's Recall

We are familiar with the properties of straight lines, the bisector of an angle, circle and triangles etc.

We will now introduce co-ordinate geometry in the study of a plane. Every point has got pair of co-ordinates and every pair of co-ordinate gives us a point in the plane.

We will use this and study the curves with the help of co-ordinates of the points.

What is the perpendicular bisector of a segment ? ..... A line.

What is the bisector of an angle ? .....A ray.

These geometrical figures are sets of points in plane which satisfy certain conditions.

- The perpendicular bisector of a segment is the set of points in the plane which are equidistant from the end points of the segment. This set is a line.
- The bisector of an angle is the set of points in the plane which are equidistant from the arms of the angle. This set is a ray.

**Activity :** Draw segment AB of length 6 cm. Plot a few points which are equidistant from A and B. Verify that they are collinear.

## Let's Learn

**5.1 Locus :** A set of points in a plane which satisfy certain geometrical condition (or conditions) is called a locus.

$L = \{ P \mid P \text{ is a point in the plane and } P \text{ satisfies given geometrical condition} \}$

Here P is the representative of all points in L. L is called the *locus* of point P. Locus is a set of points.

The locus can also be described as the route of a point which moves while satisfying required conditions. eg. planets in solar system.

### Illustration :

- The perpendicular bisector of segment AB is the set

$$M = \{ P \mid P \text{ is a point such that } PA=PB \}.$$

- The bisector of angle AOB is the set :

$$D = \{ P \mid P \text{ is a point such that } P \text{ is equidistant from } OA \text{ and } OB \} \\ = \{ P \mid \angle POA = \angle POB \}$$

Verify that the sets defined above are the same.

The plural of locus is loci.

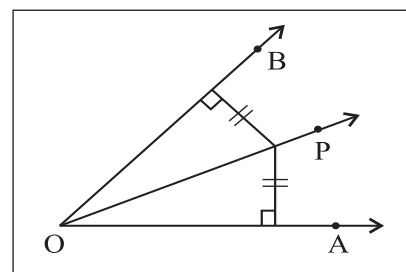

Fig. 5.1

- The circle with center O and radius 4 is the set  $L = \{ P \mid OP = 4 \}$

**5.1.1 Equation of Locus :** If the set of points, whose co-ordinates satisfy a certain equation in  $x$  and  $y$ , is the same as the set of points on a locus, then the equation is said to be the equation of the locus.

**SOLVED EXAMPLES**

**Ex.1** We know that the  $y$  co-ordinate of every point on the  $X$ -axis is zero and this is true for points on the  $X$ -axis only. Therefore the equation of the  $X$ -axis is  $y = 0$ .

**Ex.2** Let  $L = \{P \mid OP = 4\}$ . Find the equation of  $L$ .

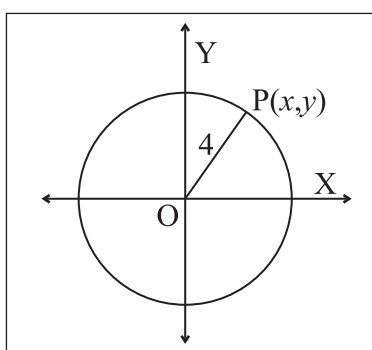

**Fig. 5.2**

**Solution :**  $L$  is the locus of points in the plane which are at 4 unit distance from the origin.

Let  $P(x, y)$  be any point on the locus  $L$ .

As  $OP = 4$ ,  $OP^2 = 16$

$$\therefore (x - 0)^2 + (y - 0)^2 = 16$$

$$\therefore x^2 + y^2 = 16$$

This is the equation of locus  $L$ .

The locus is seen to be a circle

**Ex.3** Find the equation of the locus of points which are equidistant from  $A(-3, 0)$  and  $B(3, 0)$ . Identify the locus.

**Solution :** Let  $P(x, y)$  be any point on the required locus.

$P$  is equidistant from  $A$  and  $B$ .

$$\therefore PA = PB$$

$$\therefore PA^2 = PB^2$$

$$\therefore (x + 3)^2 + (y - 0)^2 = (x - 3)^2 + (y - 0)^2$$

$$\therefore x^2 + 6x + 9 + y^2 = x^2 - 6x + 9 + y^2$$

$$\therefore 12x = 0$$

$$\therefore x = 0. \text{ The locus is the Y-axis.}$$

**5.1.2 Shift of Origin :** Let  $O'(h, k)$  be a point in the  $XY$  plane and the origin be shifted to  $O'$ . Let  $O'X'$ ,  $O'Y'$  be the new co-ordinate axes through  $O'$  and parallel to the axes  $OX$  and  $OY$  respectively.

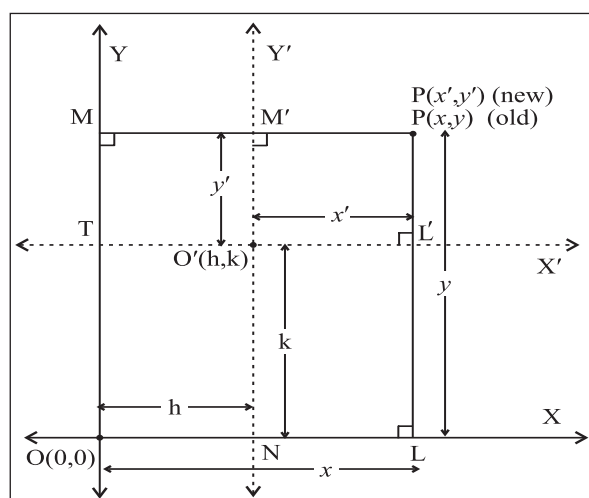

**Fig. 5.3**

Let  $(x, y)$  be the co-ordinates of  $P$  referred to the co-ordinates axes  $OX, OY$  and  $(x', y')$  be the co-ordinates of  $P$  referred to the co-ordinate axes  $O'X', O'Y'$ . To find relations between  $(x, y)$  and  $(x', y')$ .

Draw  $PL \perp OX$  and suppose it intersects  $O'X'$  in  $L'$ .

Draw  $PM \perp OY$  and suppose it intersects  $O'Y'$  in  $M'$ .

Let  $O'Y'$  meet line  $OX$  in  $N$  and  $O'X'$  meet  $OY$  in  $T$ .

$$\therefore ON = h, OT = k, OL = x, OM = y,$$

$$O'L' = x', O'M' = y'$$

$$\text{Now } x = OL = ON + NL = ON + O'L'$$

$$= h + x'$$

$$\text{and } y = OM = OT + TM = OT + O'M' = k + y'$$

$$\therefore x = x' + h, y = y' + k$$

These equations are known as the formulae for shift of origin.

Note that the new co-ordinates can also be given by (X, Y) or (u,v) in place of (x',y').

**SOLVED EXAMPLES**

**Ex. 1)** If the origin is shifted to the point O'(3, 2) the directions of the axes remaining the same, find the new co-ordinates of the points

(a)A(4, 6) (b) B(2,-5).

**Solution :** We have (h, k) = (3,2)

$$x = x' + h, y = y' + k$$

$$\therefore x = x' + 3. \text{ and } y = y' + 2 \dots\dots\dots (1)$$

(a) (x, y) = (4, 6)

$$\therefore \text{From (1), we get } 4 = x' + 3, 6 = y' + 2$$

$$\therefore x' = 1 \text{ and } y' = 4.$$

New co-ordinates of A are (1, 4)

(ii) (x, y) = ( 2,-5)

$$\text{from (1), we get } 2 = x' + 3, -5 = y' + 2$$

$$\therefore x' = -1 \text{ and } y' = -7. \text{ New co-ordinates of B are } (-1,-7)$$

**Ex. 2)** The origin is shifted to the point (-2, 1), the axes being parallel to the original axes. If the new co-ordinates of point A are (7, -4), find the old co-ordinates of point A.

**Solution :** We have (h, k) = (-2, 1) and if new co-ordinates are (X,Y).

$$x = X + h, y = Y + k$$

$$\therefore x = X - 2, y = Y + 1$$

(X, Y) = (7, -4)

$$\text{we get } x = 7 - 2 = 5, y = -4 + 1 = - 3.$$

$$\therefore \text{Old co-ordinates A are } (5, -3)$$

**Ex. 3)** Obtain the new equation of the locus  $x^2 - xy - 2y^2 - x + 4y + 2 = 0$  when the origin is shifted to (2, 3), the directions of the axes remaining the same.

**Solution :** Here (h, k) = (2, 3) and if new co-ordinates are (X,Y).

$$\therefore x = X + h, y = Y + k \text{ gives}$$

$$\therefore x = X + 2, y = Y + 3$$

The given equation

$$x^2 - xy - 2y^2 - x + 4y + 2 = 0 \text{ becomes } (X+2)^2 - (X + 2)(Y + 3) - 2(Y + 3)^2 - (X + 2) + 4(Y + 3) + 2 = 0$$

$$\therefore X^2 - XY - 2Y^2 - 10Y - 8 = 0$$

This is the new equation of the given locus.

**EXERCISE 5.1**

1. If A(1,3) and B(2,1) are points, find the equation of the locus of point P such that PA = PB.
2. A(-5, 2) and B(4, 1). Find the equation of the locus of point P, which is equidistant from A and B.
3. If A(2, 0) and B(0, 3) are two points, find the equation of the locus of point P such that AP = 2BP.
4. If A(4, 1) and B(5, 4), find the equation of the locus of point P if PA<sup>2</sup> = 3PB<sup>2</sup>.
5. A(2, 4) and B(5, 8), find the equation of the locus of point P such that PA<sup>2</sup> - PB<sup>2</sup> = 13.
6. A(1, 6) and B(3, 5), find the equation of the locus of point P such that segment AB subtends right angle at P. ( $\angle APB = 90^\circ$ )
7. If the origin is shifted to the point O'(2, 3), the axes remaining parallel to the original axes, find the new co-ordinates of the points  
(a) A(1, 3) (b) B(2, 5)

8. If the origin is shifted to the point  $O'(1, 3)$  the axes remaining parallel to the original axes, find the old co-ordinates of the points  
 (a)  $C(5, 4)$  (b)  $D(3, 3)$
9. If the co-ordinates  $A(5, 14)$  change to  $B(8, 3)$  by shift of origin, find the co-ordinates of the point where the origin is shifted.
10. Obtain the new equations of the following loci if the origin is shifted to the point  $O'(2, 2)$ , the direction of axes remaining the same :  
 (a)  $3x - y + 2 = 0$   
 (b)  $x^2 + y^2 - 3x = 7$   
 (c)  $xy - 2x - 2y + 4 = 0$   
 (d)  $y^2 - 4x - 4y + 12 = 0$

**5.2 Straight Line :** The simplest locus in a plane is a line. The characteristic property of this locus is that if we find the slope of a segment joining any two points on this locus, then the slope is constant.

If a line meets the X-axis in the point  $A(a, 0)$ , then 'a' is called the X-intercept of the line. If it meets the Y-axis in the point  $B(0, b)$  then 'b' is called the Y-intercept of the line.

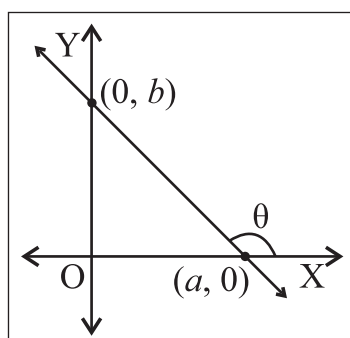

Fig. 5.4

**Remarks :**

- (1) A line parallel to X-axis has no X-intercept.
- (2) A line parallel to Y-axis has no Y-intercept.

**Let's Think :**

- Can intercept of a line be zero ?
- Can intercept of a line be negative ?

**5.1.2 Inclination of a line :** The smallest angle made by a line with the positive direction of the X-axis measured in anticlockwise sense is called the inclination of the line. We denote inclination by  $\theta$ . Clearly  $0^\circ \leq \theta < 180^\circ$ .

**Remark :** Two lines are parallel if and only if they have the same inclination.

The inclination of the X-axis and a line parallel to the X-axis is Zero. The inclination of the Y-axis and a line parallel to the Y-axis is  $90^\circ$ .

**5.2.2 Slope of a line :** If the inclination of a line is  $\theta$  then  $\tan\theta$  (if it exist) is called the slope of the line. We denote it by  $m$ .  
 $\therefore m = \tan\theta$ .

**Activity :** If  $A(x_1, y_1)$ ,  $B(x_2, y_2)$  are any two points on a non-vertical line whose inclination is  $\theta$  then verify that

$$\tan \theta = \frac{y_2 - y_1}{x_2 - x_1}, \text{ where } x_1 \neq x_2.$$

The slope of the Y-axis is not defined. Similarly the slope of a line parallel to the Y-axis is not defined. The slope of the X-axis is 0. The slope of a line parallel to the X-axis is also 0.

**Remark :** Two lines are parallel if and only if they have the same slope.

**SOLVED EXAMPLES**

**Ex. 1)** Find the slope of the line whose inclination is  $60^\circ$ .

**Solution :** The tangent ratio of the inclination of a line is called the slope of the line.

Inclination  $\theta = 60^\circ$ .

$\therefore$  slope =  $\tan\theta = \tan 60^\circ = \sqrt{3}$ .

**Ex. 2)** Find the slope of the line which passes through the points A(2, 4) and B(5, 7).

**Solution :** The slope of the line passing through the points  $(x_1, y_1)$  and  $(x_2, y_2)$  is given by

$$\frac{y_2 - y_1}{x_2 - x_1}$$

$$\text{Slope of the line AB} = \frac{y_2 - y_1}{x_2 - x_1} = \frac{7-4}{5-2} = 1$$

Note that  $x_1 \neq x_2$ .

**Ex. 3)** Find the slope of the line which passes through the origin and the point A(-4, 4).

**Solution :** The slope of the line passing through the points  $(x_1, y_1)$  and  $(x_2, y_2)$  is given by

$$m = \frac{y_2 - y_1}{x_2 - x_1}$$

Here A(-4, 4) and O(0, 0).

$$\text{Slope of the line OA} = \frac{y_2 - y_1}{x_2 - x_1} = \frac{0-4}{0+4} = -1.$$

Note that  $x_1 \neq x_2$ .

**5.2.3 Perpendicular Lines :** We know that the co-ordinate axes are perpendicular to each other. Similarly a horizontal line and a vertical line are perpendicular to each other. Slope of one of them is zero whereas the slope of the other one is not defined.

Let us obtain a relation between slopes of non-vertical lines.

**Theorem :** Non-vertical lines having slopes  $m_1$  and  $m_2$  are perpendicular to each other if and only if  $m_1 \times m_2 = -1$ .

**Proof :** Let  $\alpha$  and  $\beta$  be inclinations of lines having slopes  $m_1$  and  $m_2$ . As lines are non vertical  $\alpha \neq \frac{\pi}{2}$  and  $\beta \neq \frac{\pi}{2}$

$$\therefore \tan \alpha = m_1 \text{ and } \tan \beta = m_2$$

From Fig. 5.5 and 5.6 we have,

$$\begin{aligned} \alpha - \beta &= 90^\circ \text{ or } \alpha - \beta = -90^\circ \\ \alpha - \beta &= \pm 90^\circ \\ \therefore \cos(\alpha - \beta) &= 0 \\ \therefore \cos \alpha \cos \beta + \sin \alpha \sin \beta &= 0 \\ \therefore \sin \alpha \sin \beta &= -\cos \alpha \cos \beta \\ \therefore \tan \alpha \tan \beta &= -1 \\ \therefore m_1 m_2 &= -1 \end{aligned}$$

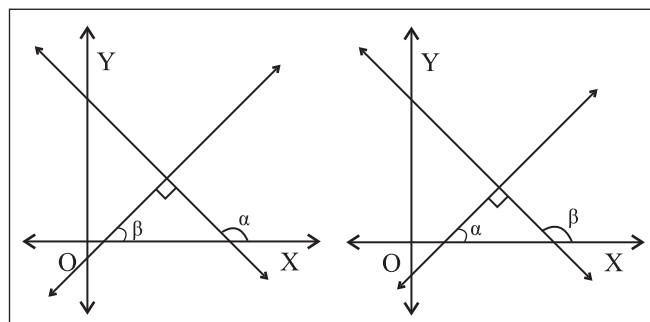

Fig. 5.5

Fig. 5.6

**SOLVED EXAMPLES**

**Ex. 1)** Show that line AB is perpendicular to line BC, where A(1, 2), B(2, 4) and C(0, 5).

**Solution :** Let slopes of lines AB and BC be  $m_1$  and  $m_2$  respectively.

$$\therefore m_1 = \frac{4-2}{2-1} = 2 \text{ and}$$

$$m_2 = \frac{y_2 - y_1}{x_2 - x_1} = \frac{5-4}{0-2} = -\frac{1}{2}$$

$$\text{Now } m_1 \times m_2 = 2 \times \left(-\frac{1}{2}\right) = -1$$

$\therefore$  Line AB is perpendicular to line BC.

**Ex. 2)** A(1,2), B(2,3) and C(-2,5) are vertices of  $\Delta$  ABC. Find the slope of the altitude drawn from A.

**Solution :** The slope of line BC is

$$m_1 = \frac{y_2 - y_1}{x_2 - x_1} = \frac{5-3}{-2-2} = -\frac{2}{4} = -\frac{1}{2}$$

Altitude drawn from A is perpendicular to BC.

If  $m_2$  is the slope of the altitude from A then  $m_1 \times m_2 = -1$ .

$$\therefore m_2 = \frac{-1}{m_1} = 2.$$

The slope of the altitude drawn from A is 2.

### 5.2.4 Angle between intersecting lines :

We have obtained relation between slopes of lines which are perpendicular to each other. If given lines are not perpendicular to each other then how to find angle between them? Let us derive formula to find the acute angle between intersecting lines.

**Theorem :** If  $\theta$  is the acute angle between non-vertical lines having slopes  $m_1$  and  $m_2$  then

$$\tan\theta = \left| \frac{m_1 - m_2}{1 + m_1 m_2} \right|$$

**Proof :** Let  $\alpha$  and  $\beta$  be the inclinations of non-vertical lines having slopes  $m_1$  and  $m_2$ .  $\alpha \neq 90^\circ$  and  $\beta \neq 90^\circ$ .

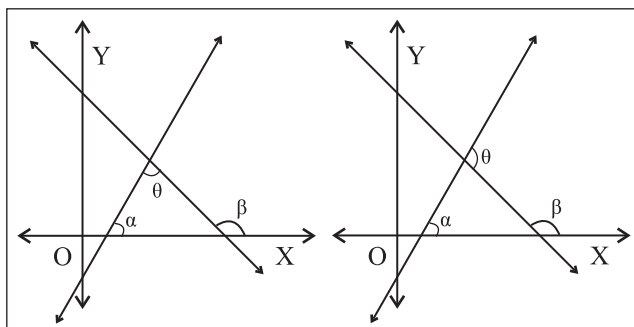

Fig. 5.7

Fig. 5.8

$$\therefore \tan\alpha = m_1 \text{ and } \tan\beta = m_2$$

From Fig. 5.7 and 5.8, we observe that

$$\theta = \beta - \alpha \text{ or } \theta = \pi - (\beta - \alpha)$$

$$\therefore \tan\theta = \tan(\beta - \alpha) \text{ or } \tan\theta = \tan\{\pi - (\beta - \alpha)\} \\ = -\tan(\beta - \alpha)$$

$$\therefore \tan\theta = |\tan(\beta - \alpha)| = |\tan(\alpha - \beta)|$$

$$\therefore \tan\theta = \left| \frac{\tan\alpha - \tan\beta}{1 + \tan\alpha \tan\beta} \right| = \left| \frac{m_1 - m_2}{1 + m_1 m_2} \right|$$

Note that as  $\theta$  is the acute angle, lines are not perpendicular to each other. Hence  $m_1 m_2 \neq -1$ .

$$\therefore 1 + m_1 m_2 \neq 0$$

### SOLVED EXAMPLES

**Ex. 1)** Find the acute angle between lines having slopes 3 and  $-2$ .

**Solution :** Let  $m_1 = 3$  and  $m_2 = -2$ .

Let  $\theta$  be the acute angle between them.

$$\therefore \tan\theta = \left| \frac{m_1 - m_2}{1 + m_1 m_2} \right| = \left| \frac{3 - (-2)}{1 + (3)(-2)} \right| = \left| \frac{5}{-5} \right| = 1$$

$$\therefore \theta = 45^\circ$$

The acute angle between lines having slopes 3 and  $-2$  is  $45^\circ$ .

**Ex. 2)** If the angle between two lines is  $45^\circ$  and the slope of one of the lines is  $\frac{1}{2}$ , find the slope of the other line.

**Solution :** If  $\theta$  is the acute angle between lines having slopes  $m_1$  and  $m_2$  then

$$\tan\theta = \left| \frac{m_1 - m_2}{1 + m_1 m_2} \right|$$

$$\text{Given } \theta = 45^\circ.$$

Let  $m_1 = \frac{1}{2}$ . Let  $m_2$  be the slope of the other line.

$$\tan 45^\circ = \left| \frac{\frac{1}{2} - m_2}{1 + \left(\frac{1}{2}\right)m_2} \right| \quad \therefore 1 = \left| \frac{1 - 2m_2}{2 + m_2} \right|$$

$$\therefore \frac{1 - 2m_2}{2 + m_2} = 1 \text{ or } \frac{1 - 2m_2}{2 + m_2} = -1$$

$$\therefore m_2 = 3 \text{ or } -\frac{1}{3}$$

There are two lines which satisfy the given conditions.

**EXERCISE 5.2**

- Find the slope of each of the following lines which passes through the points :  
 (a) A(2,-1), B(4,3) (b) C(-2,3), D(5,7)  
 (c) E(2,3), F(2,-1) (d) G(7,1), H(-3,1)
- If the X and Y-intercepts of line L are 2 and 3 respectively then find the slope of line L.
- Find the slope of the line whose inclination is  $30^\circ$ .
- Find the slope of the line whose inclination is  $\frac{\pi}{4}$ .
- A line makes intercepts 3 and 3 on the co-ordinate axes. Find the inclination of the line.
- Without using Pythagoras theorem show that points A(4,4), B(3, 5) and C(-1, -1) are the vertices of a right angled triangle.
- Find the slope of the line which makes angle of  $45^\circ$  with the positive direction of the Y-axis measured anticlockwise.
- Find the value of k for which points P(k,-1), Q(2,1) and R(4,5) are collinear.
- Find the acute angle between the X-axis and the line joining points A(3,-1) and B(4,-2).
- A line passes through points A( $x_1, y_1$ ) and B( $h, k$ ). If the slope of the line is  $m$  then show that  $k - y_1 = m(h - x_1)$ .
- If points A( $h, 0$ ), B(0,  $k$ ) and C( $a, b$ ) lie on a line then show that  $\frac{a}{h} + \frac{b}{k} = 1$ .

**5.3 Equation of line in standard forms :** An equation in  $x$  and  $y$  which is satisfied by the co-ordinates of all points on a line and no other points is called the equation of the line.

The  $y$  co-ordinate of every point on the X-axis is 0 and this is true only for points on the X-axis. Therefore, the equation of the X-axis is  $y = 0$

The  $x$  co-ordinate of every point on the Y-axis is 0 and this is true only for points on the Y-axis. Therefore, the equation of the Y-axis is  $x = 0$ .

The equation of any line parallel to the Y-axis is of the type  $x = k$  (where  $k$  is a constant) and the equation of any line parallel to the X-axis is of the type  $y = k$ . This is all about vertical and horizontal lines.

Let us obtain equations of non-vertical and non -horizontal lines in different forms:

**5.3.1 Point-slope Form :** To find the equation of the line having slope  $m$  and which passes through the point A( $x_1, y_1$ ).

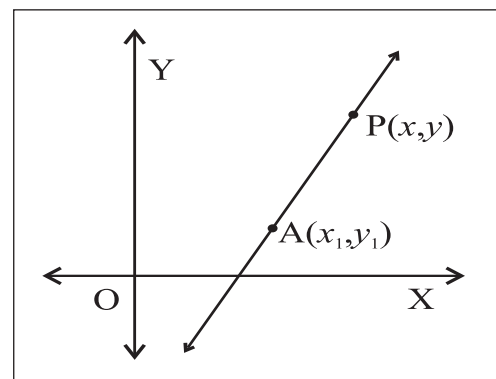

**Fig. 5.9**

**Proof :** Let L be the line passing through the point A( $x_1, y_1$ ) and which has slope  $m$ .

Let P( $x, y$ ) be any point on the line L other than A.

Then the slope of line L =  $\frac{y - y_1}{x - x_1}$ .

But the slope of line L is  $m$ . (given)

$$\therefore \frac{y - y_1}{x - x_1} = m$$

$\therefore$  The equation of the line L is

$$(y - y_1) = m (x - x_1)$$

The equation of the line having slope  $m$  and passing through  $A(x_1, y_1)$  is  
 $(y - y_1) = m(x - x_1)$ .

**Remark :** In particular if the line passes through the origin  $O(0,0)$  and has slope  $m$ , then its equation is  $y - 0 = m(x - 0)$

$$\therefore y = mx$$

**Ex.** Find the equation of the line passing through the point  $A(2, 1)$  and having slope  $-3$ .

**Soln. :** Given line passes through the point  $A(2, 1)$  and slope of the line is  $-3$ .

The equation of the line having slope  $m$  and passing through  $A(x_1, y_1)$  is  
 $(y - y_1) = m(x - x_1)$ .

The equation of the required line is

$$y - 1 = -3(x - 2)$$

$$\therefore y - 1 = -3x + 6$$

$$\therefore 3x + y - 7 = 0$$

**5.3.2 Slope-Intercept form :** To find the equation of line having slope  $m$  and which makes intercept  $c$  on the Y-axis.

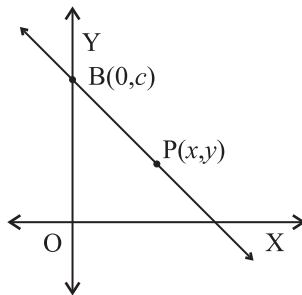

**Fig. 5.10**

**Proof :** Let  $L$  be the line with slope  $m$  and which makes Y-intercept  $c$ . Line  $L$  meets the Y-axis in the point  $C(0, c)$ .

Let  $P(x, y)$  be any point on the line other than  $C$ . Then the slope of the line  $L$  is

$$\frac{y - c}{x - 0} = m \text{ (given)}$$

$$\therefore \frac{y - c}{x} = m$$

$$\therefore y = mx + c$$

This is the equation of line  $L$ .

The equation of line having slope  $m$  and which makes intercept  $c$  on the Y-axis is  $y = mx + c$ .

**Ex.** Obtain the equation of line having slope 3 and which makes intercept 4 on the Y-axis.

**Solution :** The equation of line having slope  $m$  and which makes intercept  $c$  on the Y-axis is

$$y = mx + c.$$

$\therefore$  the equation of the line giving slope 3 and making Y-intercept 4 is  $y = 3x + 4$ .

**5.3.3 Two-points Form :** To find the equation of line which passes through points  $A(x_1, y_1)$  and  $B(x_2, y_2)$ .

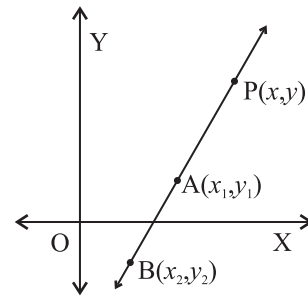

**Fig. 5.11**

**Proof :**  $A(x_1, y_1)$  and  $B(x_2, y_2)$  are the two given points on the line  $L$ . Let  $P(x, y)$  be any point on the line  $L$ , other than  $A$  and  $B$ . Now points  $A$  and  $P$  lie on the line  $L$ .

$$\text{The slope of line } L = \frac{y - y_1}{x - x_1} \dots\dots\dots (1)$$

Also points  $A$  and  $B$  lie on the line  $L$ .

$$\therefore \text{Slope of line } L = \frac{y_2 - y_1}{x_2 - x_1} \dots\dots\dots (2)$$

From (1) and (2) we get  $\frac{y - y_1}{x - x_1} = \frac{y_2 - y_1}{x_2 - x_1}$

$$\therefore \frac{x - x_1}{x_2 - x_1} = \frac{y - y_1}{y_2 - y_1}$$

This is the equation of line  $L$ .

As line is non-vertical and non-horizontal,  $x_1 \neq x_2$  and  $y_1 \neq y_2$ .

The equation of the line which passes through points  $A(x_1, y_1)$  and  $B(x_2, y_2)$  is  $\frac{x-x_1}{x_2-x_1} = \frac{y-y_1}{y_2-y_1}$

**Ex.** Obtain the equation of the line passing through points  $A(2, 1)$  and  $B(1, 2)$ .

**Solution :** The equation of the line which passes through points  $A(x_1, y_1)$  and  $B(x_2, y_2)$  is

$$\frac{x-x_1}{x_2-x_1} = \frac{y-y_1}{y_2-y_1}$$

$\therefore$  The equation of the line passing through points  $A(2, 1)$  and  $B(1, 2)$  is  $\frac{x-2}{1-2} = \frac{y-1}{2-1}$

$$\therefore \frac{x-2}{-1} = \frac{y-1}{1}$$

$$\therefore x - 2 = -y + 1$$

$$\therefore x + y - 3 = 0$$

**5.3.4 Double-Intercept form :** To find the equation of the line which makes non-zero intercepts  $a$  and  $b$  on the co-ordinate axes.

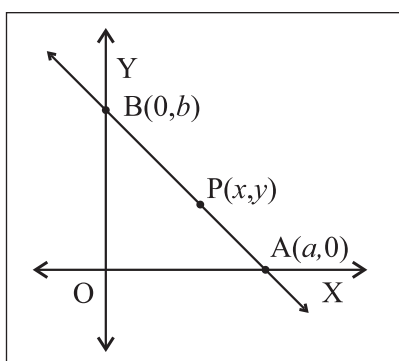

Fig. 5.12

Let  $a$  be the X-intercept and  $b$  be the Y-intercept of line L.

$\therefore$  Line L meets the X-axis in  $A(a, 0)$  and the Y-axis in  $B(0, b)$ .

Let  $P(x, y)$  be any point on line L other than A and B.

$\therefore$  The slope of line L = slope of line AP

$$= \frac{y-0}{x-a} = \frac{y}{x-a}$$

$$\begin{aligned} \therefore \text{The slope of the line L} &= \text{Slope of AB} \\ &= \frac{b-0}{0-a} = \frac{-b}{a} \end{aligned}$$

$$\therefore \frac{y}{x-a} = \frac{-b}{a} \quad \therefore \frac{x}{a} + \frac{y}{b} = 1$$

This is the equation of line L.

The equation of the line which makes intercepts  $a$  and  $b$  on the co-ordinate axes is

$$\frac{x}{a} + \frac{y}{b} = 1 \quad (a, b \neq 0)$$

**Ex.** Obtain the equation of the line which makes intercepts 3 and 4 on the co-ordinate axes.

**Solution :** The equation of the line which makes intercepts  $a$  and  $b$  on the co-ordinate

$$\text{axes } \frac{x}{a} + \frac{y}{b} = 1$$

The equation of the line which makes intercepts 3 and 4 on the co-ordinate axes is  $\frac{x}{3} + \frac{y}{4} = 1$

$$\therefore 4x + 3y - 12 = 0.$$

**5.3.5 Normal Form :** Let L be a line and segment ON be the perpendicular (normal) drawn from the origin to line L.

If  $ON = p$  and ray ON makes angle  $\alpha$  with the positive X-axis then to find the equation of line L.

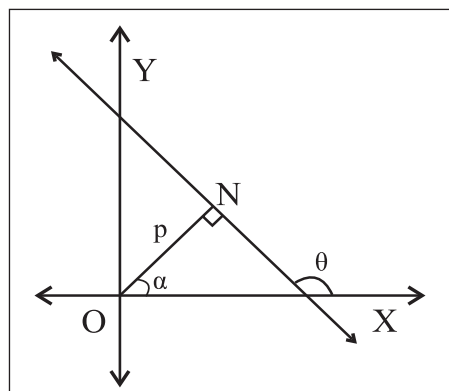

Fig. 5.13

From Fig. 5.13 we observe that N is

$(p \cos \alpha, p \sin \alpha)$

Therefore slope of ON is  $\frac{p \sin \alpha - 0}{p \cos \alpha - 0} = \tan \alpha$

As ON is perpendicular to line L,

Slope of line L =  $\tan \theta = -\cot \alpha$

And it passes through  $(p \cos \alpha, p \sin \alpha)$

$\therefore$  By the point - slope form, the equation of line L is,

$$y - p \sin \alpha = \frac{-\cos \alpha}{\sin \alpha} (x - p \cos \alpha)$$

$$y \sin \alpha - p \sin^2 \alpha = x \cos \alpha + p \cos^2 \alpha$$

$$x \cos \alpha + y \sin \alpha = (\sin^2 \alpha \cos^2 \alpha)$$

$$x \cos \alpha + y \sin \alpha = p \quad (p > 0)$$

The equation of the line, the normal to which from the origin has length  $p$  and the normal makes angle  $\alpha$  with the positive directions of the X-axis, is  $x \cos \alpha + y \sin \alpha = p$ .

### SOLVED EXAMPLES

**Ex. 1)** The perpendicular drawn from the origin to a line has length 5 and the perpendicular makes angle with the positive direction of the X-axis. Find the equation of the line.

**Solution :** The perpendicular (normal) drawn from the origin to a line has length 5.

$$\therefore p = 5$$

The perpendicular (normal) makes angle  $30^\circ$  with the positive direction of the X-axis.

$$\therefore \theta = 30^\circ$$

The equation of the required line is  $x \cos \alpha + y \sin \alpha = p$

$$\therefore x \cos 30^\circ + y \sin 30^\circ = p$$

$$\therefore \frac{\sqrt{3}}{2}x + \frac{1}{2}y = 5$$

$$\therefore \sqrt{3}x + y - 10 = 0$$

**Ex. 2)** Reduce the equation  $\sqrt{3}x - y - 2 = 0$  into normal form. Find the values of  $p$  and  $\alpha$ .

**Solution :** Comparing  $\sqrt{3}x - y - 2 = 0$  with  $ax + by + c = 0$  we get  $a = \sqrt{3}$ ,  $b = -1$  and  $c = -2$ .

$$\sqrt{a^2 + b^2} = \sqrt{3 + 1} = 2$$

Divide the given equation by 2.

$$\frac{\sqrt{3}}{2}x - \frac{1}{2}y = 1$$

$\therefore \cos 330^\circ x + \sin 330^\circ y = 1$  is the required normal form of the given equation.

$$p = 1 \quad \text{and} \quad \theta = 330^\circ.$$

**Ex. 3)** Find the equation of the line :

- (i) parallel to the X-axis and 3 unit below it,
- (ii) passing through the origin and having inclination  $30^\circ$
- (iii) passing through the point  $A(5,2)$  and having slope 6
- (iv) passing through the points  $A(2,-1)$  and  $B(5,1)$
- (v) having slope  $-\frac{3}{4}$  and y-intercept 5,
- (vi) making intercepts 3 and 6 on the co-ordinate axes.
- (vii) passing through the point  $N(-2,3)$  and the segment of the line intercepted between the co-ordinate axes is bisected at N.

**Solution :** (i) Equation of line parallel to the X-axis is of the form :  $y = k$ ,

$\therefore$  the equation of the required line is

$$y = 3$$

(ii) Equation of line through the origin and having slope  $m$  is of the form :  $y = mx$ .

$$\text{slope} = m = \tan 30^\circ = \frac{1}{\sqrt{3}}$$

$\therefore$  the equation of the required line is

$$y = \frac{1}{\sqrt{3}}x \quad \therefore \sqrt{3}x - y = 0$$

(iii) By using the point-slope form

$$y - y_1 = m(x - x_1)$$

$$\text{slope} = m = -6$$

Equation of the required line is

$$(y - 2) = -6(x + 5)$$

$$6x + y + 28 = 0$$

(iv) By using the two points form

$$\frac{x - x_1}{x_2 - x_1} = \frac{y - y_1}{y_2 - y_1}$$

Here  $(x_1, y_1) = (2, -1)$ ;  $(x_2, y_2) = (5, 1)$

$\therefore$  the equation of the required line is

$$\frac{x - 2}{5 - 2} = \frac{y + 1}{1 + 1}$$

$$\therefore 2(x - 2) = 3(y + 1)$$

$$\therefore 2x - 3y - 7 = 0$$

(v) By using the slope intercept form  $y = mx + c$

$$\text{Given } m = -\frac{3}{4}, \quad c = 5$$

$\therefore$  the equation of the required line is

$$y = -\frac{3}{4}x + 5 \quad \therefore 3x + 4y - 20 = 0$$

(vi) By using the double intercept form

$$\frac{x}{a} + \frac{y}{b} = 1$$

x-intercept =  $a = 3$  ; y-intercept =  $b = 6$  .

the equation of the required line is  $\frac{x}{3} + \frac{y}{6} = 1$   
 $2x + y - 6 = 0$

(vii) Let the given line meet the X-axis in  $A(a, 0)$  and the Y-axis in  $B(0, b)$ .

The mid-point of AB is

$$\left( \frac{a + 0}{2}, \frac{0 + b}{2} \right) = (-2, 3)$$

$$\therefore \frac{a}{2} = -2 \quad \text{and} \quad \frac{b}{2} = 3$$

$$\therefore a = -4 \quad b = 6$$

$\therefore$  By using the double intercept form :

$$\frac{x}{a} + \frac{y}{b} = 1 \quad \frac{x}{-4} + \frac{y}{6} = 1 \quad \therefore 3x - 2y + 12 = 0$$

### An interesting property of a straight line.

Consider any straight line in a plane. It makes two parts of the points which are not on the line.

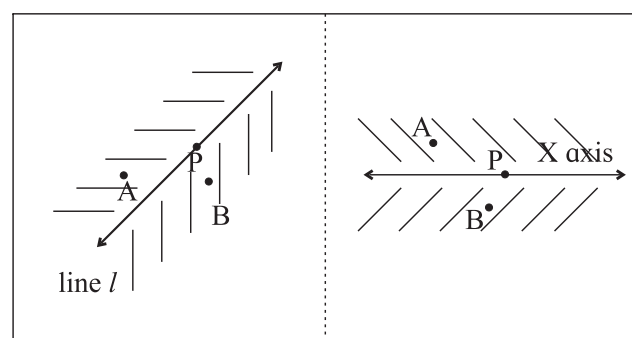

Fig. 5.14

Thus the plane is divided into 3 parts, the points on the line, points on one side of the line and points on the other side of the line.

If the line is given by  $ax+by+c = 0$ , then for all points  $(x_1, y_1)$  on one side of the line  $ax_1+by_1+c > 0$  and for all points  $(x_2, y_2)$  on the other side of the line,  $ax_2+by_2+c < 0$ .

For example, consider the line given by  $y - 2x - 3 = 0$ . Points  $P(-2,0)$ ,  $Q(-2,4)$ ,  $R(\frac{1}{2}, 5)$  lie on one side and at each of those points,  $y - 2x - 3 > 0$ . The points  $A(0,0)$ ,  $B(\frac{1}{2}, 3)$ ,  $C(8,4)$  lie on the other side of the line and at each of those points  $y - 2x - 3 < 0$ .

**Activity :**

Draw the straight lines given by  $2y + x = 5$ ,  $x = 1$ ,  $6y - x + 1 = 0$  give 4 points on each side of the lines and check the property stated above.

**EXERCISE 5.3**

- Write the equation of the line :
  - parallel to the X-axis and at a distance of 5 unit form it and above it.
  - parallel to the Y-axis and at a distance of 5 unit form it and to the left of it.
  - parallel to the X-axis and at a distance of 4 unit form the point  $(-2, 3)$ .
- Obtain the equation of the line :
  - parallel to the X-axis and making an intercept of 3 unit on the Y-axis.
  - parallel to the Y-axis and making an intercept of 4 unit on the X-axis.
- Obtain the equation of the line containing the point :
  - $A(2,-3)$  and parallel to the Y-axis.
  - $B(4,-3)$  and parallel to the X-axis.

- Find the equation of the line
  - passing through the points  $A(2,0)$  and  $B(3,4)$ .
  - passing through the points  $P(2,1)$  and  $Q(2,-1)$
- Find the equation of the line
  - containing the origin and having inclination  $60^\circ$ .
  - passing through the origin and parallel to AB, where A is  $(2,4)$  and B is  $(1,7)$ .
  - having slope  $\frac{1}{2}$  and containing the point  $(3,-2)$ .
  - containing the point  $A(3,5)$  and having slope  $\frac{2}{3}$ .
  - containing the point  $A(4,3)$  and having inclination  $120^\circ$ .
  - passing through the origin and which bisects the portion of the line  $3x+y=6$  intercepted between the co-ordinate axes.
- Line  $y = mx + c$  passes through points  $A(2,1)$  and  $B(3,2)$ . Determine  $m$  and  $c$ .
- Find the equation of the line having inclination  $135^\circ$  and making X-intercept 7.
- The vertices of a triangle are  $A(3,4)$ ,  $B(2,0)$  and  $C(-1,6)$ . Find the equations of the lines containing
  - side BC
  - the median AD
  - the mid points of sides AB and BC.
- Find the  $x$  and  $y$  intercepts of the following lines :
  - $\frac{x}{3} + \frac{y}{2} = 1$
  - $\frac{3x}{2} + \frac{2y}{3} = 1$
  - $2x - 3y + 12 = 0$

10. Find equations of lines which contains the point  $A(1,3)$  and the sum of whose intercepts on the co-ordinate axes is zero.
11. Find equations of lines containing the point  $A(3,4)$  and making equal intercepts on the co-ordinates axes.
12. Find equations of altitudes of the triangle whose vertices are  $A(2,5)$ ,  $B(6,-1)$  and  $C(-4,-3)$ .
13. Find the equations of perpendicular bisectors of sides of the triangle whose vertices are  $P(-1,8)$ ,  $Q(4,-2)$  and  $R(-5,-3)$ .
14. Find the co-ordinates of the orthocenter of the triangle whose vertices are  $A(2,-2)$ ,  $B(1,1)$  and  $C(-1,0)$ .
15.  $N(3,-4)$  is the foot of the perpendicular drawn from the origin to line  $L$ . Find the equation of line  $L$ .

**5.4 General form of equation of a line:** We can write equation of every line in the form  $ax+by+c=0$

This form of equation of a line is called the general form.

The general form of  $y=3x+2$  is  $3x-y+2=0$

The general form of  $\frac{x}{2}+\frac{y}{3}=1$  is  $3x+2y-6=0$

The slope of the line  $ax+by+c=0$  is  $-\frac{a}{b}$  if  $b \neq 0$ .

The X-intercept is  $-\frac{c}{a}$  if  $a \neq 0$ .

The Y-intercept is  $-\frac{c}{b}$  if  $b \neq 0$ .

**Remark :** If  $a=0$  then the line is parallel to the X-axis. It does not make intercept on the X-axis.

If  $b=0$  then the line is parallel to the Y-axis. It does not make intercept on the Y-axis.

### SOLVED EXAMPLES

**Ex. 1)** Find the slope and intercepts made by the following lines :

(a)  $x+y+10=0$       (b)  $2x+y+30=0$

(c)  $x+3y-15=0$

**Solution :** (a) Comparing equation  $x+y+10=0$  with  $ax+by+c=0$ , we get  $a=1, b=1, c=10$

$\therefore$  Slope of this line =  $-\frac{a}{b} = -1$

The X-intercept is  $-\frac{c}{a} = -\frac{10}{1} = -10$

The Y-intercept is  $-\frac{c}{b} = -\frac{10}{1} = -10$

(b) Comparing equation  $2x+y+30=0$  with  $ax+by+c=0$ .

we get  $a=2, b=1, c=30$

$\therefore$  Slope of this line =  $-\frac{a}{b} = -2$

The X-intercept is  $-\frac{c}{a} = -\frac{30}{2} = -15$

The Y-intercept is  $-\frac{c}{b} = -\frac{30}{1} = -30$

(c) Comparing equation  $x+3y-15=0$  with  $ax+by+c=0$ .

we get  $a=1, b=3, c=-15$

$\therefore$  Slope of this line =  $-\frac{a}{b} = -\frac{1}{3}$

The  $x$ - intercept is  $-\frac{c}{a} = -\frac{-15}{1} = 15$

The  $y$ - intercept is  $-\frac{c}{b} = -\frac{-15}{3} = 5$

**Ex. 2)** Find the acute angle between the following pairs of lines :

a)  $12x-4y=5$  and  $4x+2y=7$

b)  $y=2x+3$  and  $y=3x+7$

**Solution :** (a) Slopes of lines  $12x-4y=5$  and  $4x+2y=7$  are  $m_1=3$  and  $m_2=2$ .

If  $\theta$  is the acute angle between lines having slope  $m_1$  and  $m_2$  then

$$\tan \theta = \left| \frac{m_1 - m_2}{1 + m_1 m_2} \right|$$

$$\therefore \tan \theta = \left| \frac{3 - (-2)}{1 + (3)(-2)} \right| = \left| \frac{5}{-5} \right| = 1$$

$$\therefore \tan \theta = 1 \quad \therefore \theta = 45^\circ$$

(b) Slopes of lines  $y=2x+3$  and  $y=3x+7$  are  $m_1=2$  and  $m_2=3$

The acute angle  $\theta$  between lines having slopes  $m_1$  and  $m_2$  is given by

$$\tan \theta = \left| \frac{m_1 - m_2}{1 + m_1 m_2} \right|$$

$$\therefore \tan \theta = \left| \frac{2 - 3}{1 + (2)(3)} \right| = \left| \frac{-1}{7} \right| = \frac{1}{7}$$

$$\therefore \theta = \tan^{-1} \left( \frac{1}{7} \right).$$

**Ex. 3)** Find the acute angle between the lines  $y - \sqrt{3}x + 1 = 0$  and  $\sqrt{3}y - x + 7 = 0$ .

**Solution :** Slopes of the given lines are  $m_1 = \sqrt{3}$  and  $m_2 = \frac{1}{\sqrt{3}}$ .

The acute angle  $\theta$  between lines having slopes  $m_1$  and  $m_2$  is given by

$$\tan \theta = \left| \frac{m_1 - m_2}{1 + m_1 m_2} \right|$$

$$\begin{aligned} \tan \theta = \frac{1}{\sqrt{3}} &= \left| \frac{\sqrt{3} - \frac{1}{\sqrt{3}}}{1 + \sqrt{3} \times \frac{1}{\sqrt{3}}} \right| = \left| \frac{\sqrt{3} - \frac{1}{\sqrt{3}}}{1 + 1} \right| = \left| \frac{\sqrt{3} - \frac{1}{\sqrt{3}}}{2} \right| \\ &= \left| \frac{1 - 3}{2\sqrt{3}} \right| = \left| \frac{-1}{\sqrt{3}} \right| = \frac{1}{\sqrt{3}} \end{aligned}$$

$$\therefore \tan \theta = \frac{1}{\sqrt{3}} \quad \therefore \theta = 30^\circ$$

**Ex. 4)** Show that following pairs of lines are perpendicular to each other.

a)  $2x-4y=5$  and  $2x+y=17$ .

b)  $y=2x+23$  and  $2x+4y=27$

**Solution :** (i) Slopes of lines  $2x-4y=5$  and

$$2x+y=17 \text{ are } m_1 = \frac{1}{2} \text{ and } m_2 = -2$$

Since  $m_1 \cdot m_2 = \frac{1}{2} \times (-2) = -1$ , given lines are perpendicular to each other.

(ii) Slopes of lines  $y = 2x + 23$  and

$$2x+4y = 27 \text{ are } m_1 = -\frac{1}{2} \text{ and } m_2 = 2.$$

Since  $m_1 \cdot m_2 = -\frac{1}{2} \times (2) = -1$ , given lines are perpendicular to each other.

**Ex. 5)** Find equations of lines which pass through the origin and make an angle of  $45^\circ$  with the line  $3x - y = 6$ .

**Solution :** Slope of the line  $3x - y = 6$  is 3. Let  $m$  be the slope of one of the required lines. The angle between these lines is  $45^\circ$ .

$$\therefore \tan 45^\circ = \left| \frac{m-3}{1+(m)(3)} \right|$$

$$\therefore 1 = \left| \frac{m-3}{1+3m} \right| \quad \therefore |1+3m| = |m-3|$$

$$\therefore 1+3m = m-3 \quad \text{or} \quad 1+3m = -(m-3)$$

$$\therefore m = -2 \quad \text{or} \quad \frac{1}{2}$$

Slopes of required lines are  $m_1 = -2$  and

$$m_2 = \frac{1}{2}$$

Required lines pass through the origin.

$\therefore$  Their equations are  $y = -2x$  and

$$y = \frac{1}{2}x$$

$$\therefore 2x + y = 0 \quad \text{and} \quad x - 2y = 0$$

**Ex. 6)** A line is parallel to the line  $2x + y = 7$  and passes through the origin. Find its equation.

**Solution :** Slope of the line  $2x + y = 7$  is  $-2$ . Required line passes through the origin.

$\therefore$  It's equation is  $y = -2x$

$$\therefore 2x + y = 0.$$

**Ex. 7)** A line is parallel to the line  $x + 3y = 9$  and passes through the point  $A(2,7)$ . Find its equation.

**Solution :** Slope of the line  $x + 3y = 9$  is  $-\frac{1}{3}$

Required line passes through the point  $A(2,7)$ .

$\therefore$  It's equation is given by the formula

$$(y - y_1) = m(x - x_1)$$

$$\therefore (y - 7) = -\frac{1}{3}(x - 2)$$

$$\therefore 3y - 21 = x - 2$$

$$\therefore x + 3y = 23.$$

**Ex. 8)** A line is perpendicular to the line  $3x + 2y - 1 = 0$  and passes through the point  $A(1,1)$ . Find its equation.

**Solution :** Slope of the line  $3x + 2y - 1 = 0$  is  $-\frac{3}{2}$ .

Required line is perpendicular to it.

The slope of the required line is  $\frac{2}{3}$ .

Required line passes through the point  $A(1,1)$ .

$\therefore$  It's equation is given by the formula

$$(y - y_1) = m(x - x_1)$$

$$\therefore (y - 1) = \frac{2}{3}(x - 1)$$

$$\therefore 3y - 3 = 2x - 2$$

$$\therefore 2x - 3y + 1 = 0.$$

**Note:**

**Point of intersection of lines :**

The co-ordinates of the point of intersection of two intersecting lines can be obtained by solving their equations simultaneously.

**Ex. 9)** Find the co-ordinates of the point of intersection of lines  $x + 2y = 3$  and  $2x - y = 1$ .

**Solution :** Solving equations  $x + 2y = 3$  and  $2x - y = 1$  simultaneously, we get  $x = 1$  and  $y = 1$ .

$\therefore$  Given lines intersect in point  $(1,1)$ .

**Ex. 10** Find the equation of line which is parallel to the X-axis and which passes through the point of intersection of lines  $x+2y=6$  and  $2x-y=2$

**Solution :** Solving equations  $x+2y=6$  and  $2x-y=2$  simultaneously, we get  $x=2$  and  $y=2$ .

$\therefore$  The required line passes through the point  $(2,2)$ .

As it is parallel to the X-axis, its equation is  $y=2$ .

### 5.4.1 The distance of the Origin from a Line :

The distance of the origin from the line

$ax+by+c=0$  is given by  $p = \left| \frac{c}{\sqrt{a^2+b^2}} \right|$

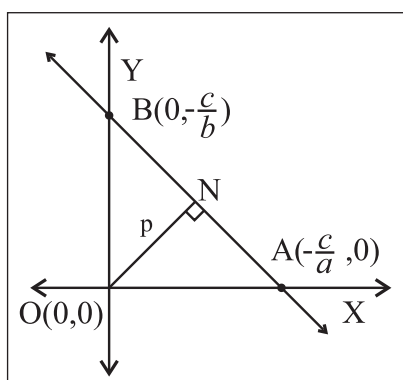

Fig. 5.15

**Proof :** Let A and B be the points where line  $ax+by+c=0$  cuts the co-ordinate axes.

$\therefore$  A  $\left(-\frac{c}{a}, 0\right)$  and B  $\left(0, -\frac{c}{b}\right)$

OA =  $\left| \frac{c}{a} \right|$  and OB =  $\left| \frac{c}{b} \right|$

By Pythagoras theorem  $AB^2 = OA^2 + OB^2$

$$AB^2 = \left(\frac{c}{a}\right)^2 + \left(\frac{c}{b}\right)^2 = c^2 \left(\frac{a^2+b^2}{a^2b^2}\right)$$

$$\therefore AB = \left| \frac{c}{ab} \right| \sqrt{a^2+b^2}$$

Now,

$$\begin{aligned} \text{Area of } \Delta OAB &= \frac{1}{2} AB \times ON \\ &= \frac{1}{2} \left| \frac{c}{ab} \right| \sqrt{a^2+b^2} \times p \dots \text{(I)} \end{aligned}$$

$$\begin{aligned} \text{But, Area of } \Delta OAB &= \frac{1}{2} OA \times OB \\ &= \frac{1}{2} \left| \frac{c}{a} \right| \left| \frac{c}{b} \right| = \left| \frac{c^2}{2ab} \right| \dots \text{(II)} \end{aligned}$$

From (I) and (II), we get

$$p = \left| \frac{c}{\sqrt{a^2+b^2}} \right|$$

**5.4.2 The distance of the point  $(x_1, y_1)$  from a line:** The distance of the point P  $(x_1, y_1)$  from line  $ax+by+c=0$  is given by

$$p = \left| \frac{ax_1+by_1+c}{\sqrt{a^2+b^2}} \right|$$

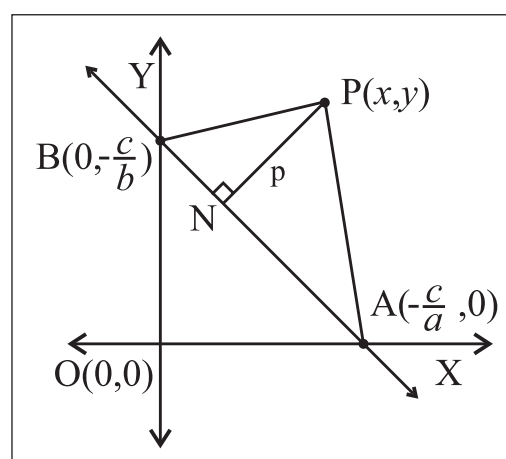

Fig. 5.16

**Proof :** If line  $ax + by + c = 0$  cuts co-ordinate axes in B and C respectively then B is  $\left(-\frac{c}{a}, 0\right)$

and C is  $\left(0, -\frac{c}{b}\right)$ .

Let PM be perpendicular to  $ax + by + c = 0$ .

Let  $PM = p$

$$A(\Delta PBC) = \frac{1}{2} BC \times PM = \frac{1}{2} p \sqrt{\frac{c^2}{a^2} + \frac{c^2}{b^2}} = \frac{pc\sqrt{a^2 + b^2}}{2ab} \quad \text{.(I)}$$

Now  $P(x_1, y_1)$ ,  $B\left(-\frac{c}{a}, 0\right)$  and  $C\left(0, -\frac{c}{b}\right)$

are vertices of PBC.

$$\therefore A(\Delta PBC) = \frac{1}{2} \begin{vmatrix} 1 & 1 & 1 \\ x_1 & -\frac{c}{a} & 0 \\ y_1 & 0 & -\frac{c}{b} \end{vmatrix} = \frac{1}{2} \left| x_1 \frac{c}{b} + y_1 \frac{c}{a} + \frac{c^2}{ab} \right| \quad \text{.(II)}$$

From (I) and (II) we get

$$\frac{pc\sqrt{a^2 + b^2}}{2ab} = \frac{1}{2} \left| x_1 \frac{c}{b} + y_1 \frac{c}{a} + \frac{c^2}{ab} \right|$$

$$\therefore pc\sqrt{a^2 + b^2} = |acx_1 + bcy_1 + c^2|$$

$$\therefore p\sqrt{a^2 + b^2} = |ax_1 + by_1 + c|$$

$$\therefore p = \left| \frac{ax_1 + by_1 + c}{\sqrt{a^2 + b^2}} \right|$$

### 5.4.3 The distance between two parallel lines :

**Theorem :** The distance between the parallel lines  $ax + by + c_1 = 0$  and  $ax + by + c_2 = 0$  is given

$$\text{by } p = \left| \frac{c_1 - c_2}{\sqrt{a^2 + b^2}} \right|$$

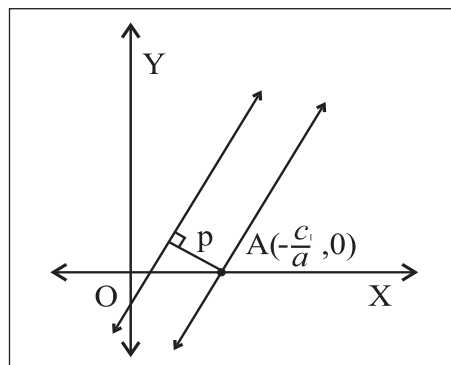

**Fig. 5.17**

**Proof :** To find the distance between parallel lines, we take any one point on any one of these two lines and find its distance from the other line.

$A\left(-\frac{c_1}{a}, 0\right)$  is a point on the first line.

Its distance from the line  $ax + by + c_2 = 0$  is given by

$$p = \left| \frac{a\left(-\frac{c_1}{a}\right) + b(0) + c_2}{\sqrt{a^2 + b^2}} \right| = \left| \frac{-c_1 + c_2}{\sqrt{a^2 + b^2}} \right| = \left| \frac{c_1 - c_2}{\sqrt{a^2 + b^2}} \right|$$

### SOLVED EXAMPLES

**Ex. 1)** Find the distance of the origin from the line  $3x + 4y + 15 = 0$

**Solution :** The distance of the origin from the line  $ax + by + c = 0$  is given by

$$p = \left| \frac{c}{\sqrt{a^2 + b^2}} \right|$$

$\therefore$  The distance of the origin from the line  $3x + 4y + 15 = 0$  is given by

$$p = \left| \frac{15}{\sqrt{3^2 + 4^2}} \right| = \frac{15}{5} = 3$$

**Ex. 2)** Find the distance of the point  $P(2,5)$  from the line  $3x+4y+14=0$

**Solution :** The distance of the point  $P(x_1, y_1)$  from the line  $ax+by+c=0$  is given by

$$p = \left| \frac{ax_1 + by_1 + c}{\sqrt{a^2 + b^2}} \right|$$

$\therefore$  The distance of the point  $P(2,5)$  from the line  $3x+4y+14=0$  is given by

$$p = \left| \frac{3(2) + 4(5) + 14}{\sqrt{3^2 + 4^2}} \right| = \frac{40}{5} = 8$$

**Ex. 3)** Find the distance between the parallel lines  $6x+8y+21=0$  and  $3x+4y+7=0$ .

**Solution :** We write equation  $3x+4y+7=0$  as  $6x+8y+14=0$  in order to make the coefficients of  $x$  and coefficients of  $y$  in both equations to be same.

Now by using formula 
$$p = \left| \frac{c_1 - c_2}{\sqrt{a^2 + b^2}} \right|$$

We get the distance between the given parallel lines as

$$p = \left| \frac{21 - 14}{\sqrt{6^2 + 8^2}} \right| = \frac{7}{10}$$

**5.4.4 Family of Lines :** A set of lines which have a common property is called a family of lines. Consider the set of all lines passing through the origin. Equation of each of these lines is of the form  $y=mx$ . This set of lines is a family of lines. Different values of  $m$  give different lines.

Consider the set of all lines which pass through the point  $A(2,-3)$ . Equation of each of these

lines is of the form  $(y+3)=m(x-2)$ . This set is also form a family of lines.

Consider the set of all lines which are parallel to the line  $y=x$ . They all have the same slope.

The set of all lines which pass through a fixed point or which are parallel to each other is a family of lines.

**Interpretation of  $u + kv = 0$  :** Let  $u \equiv a_1x + b_1y + c_1$  and  $v \equiv a_2x + b_2y + c_2$

Equations  $u=0$  and  $v=0$  represent two lines. Equation  $u + kv = 0, k \in R$  represents a family of lines.

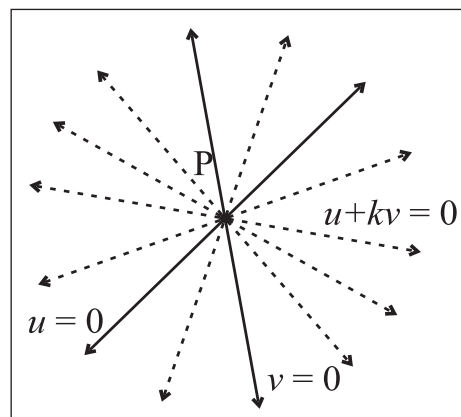

**Fig. 5.18**

In equation  $u+kv=0$  let

$$u \equiv a_1x + b_1y + c_1, \quad v \equiv a_2x + b_2y + c_2$$

We get  $(a_1x + b_1y + c_1) + k(a_2x + b_2y + c_2) = 0$

$$(a_1 + ka_2)x + (b_1 + kb_2)y + (c_1 + kc_2) = 0$$

Which is a first degree equation in  $x$  and  $y$ . Hence it represents a straight line.

i) If lines  $u=0$  and  $v=0$  intersect each other in  $P(x_1, y_1)$  then  $a_1x_1 + b_1y_1 + c_1 = 0$  and  $a_2x_1 + b_2y_1 + c_2 = 0$

Therefore

$$(a_1x_1 + b_1y_1 + c_1) + k(a_2x_1 + b_2y_1 + c_2) = 0 + k0 = 0$$

Thus line  $u + kv = 0$  passes through the point of intersection of lines  $u = 0$  and  $v = 0$  for every real value of  $k$ .

ii) If lines  $u = 0$  and  $v = 0$  are parallel to each other then their slope is same.

$$\therefore -\frac{a_1}{b_1} = -\frac{a_2}{b_2}$$

$$\therefore \text{each ratio} = -\frac{a_1 + ka_2}{b_1 + kb_2}$$

= slope of the line  $u + kv = 0$

$\therefore$  Slopes of lines  $u = 0$ ,  $v = 0$  and  $u + kv = 0$  are the same.

$\therefore$  Line  $u + kv = 0$  is parallel to lines  $u = 0, v = 0$ .

### SOLVED EXAMPLES

**Ex. 1)** Find the equation of the line which passes through the point of intersection of lines  $x + 2y + 6 = 0$ ,  $2x - y = 2$  and which makes intercept 5 on the Y-axis.

**Solution :** As the required line passes through the point of intersection of lines  $x + 2y + 6 = 0$  and  $2x - y = 2$ , its equation is of the form  $u + kv = 0$ .

$$\therefore (x + 2y + 6) + k(2x - y - 2) = 0$$

$$\therefore (1 + 2k)x + (2 - k)y + (6 - 2k) = 0$$

The Y-intercept of this line is given 5.

$$\therefore -\frac{6 - 2k}{2 - k} = 5 \quad \therefore -6 + 2k = 10 \quad 5k$$

$$\therefore 7k = 16 \quad \therefore k = \frac{16}{7}$$

$\therefore$  the equation of the required line is

$$\therefore (x + 2y + 6) + \frac{16}{7}(2x - y - 2) = 0$$

$$\therefore (7x + 14y + 42) + (32x - 16y - 32) = 0$$

$$\therefore 39x - 2y + 10 = 0$$

**Ex. 2)** Find the equation of line which passes through the point of intersection of lines  $3x + 2y - 6 = 0$ ,  $x + y + 1 = 0$  and the point A(2,1).

**Solution :** Since the required line passes through the point of intersection of lines

$3x + 2y - 6 = 0$  and  $x + y + 1 = 0$ , its equation is of the form  $u + kv = 0$ .

$$\therefore (3x + 2y - 6) + k(x + y + 1) = 0$$

$$\therefore (3 + k)x + (2 + k)y + (-6 + k) = 0$$

This line passes through the point A(2,1).

$\therefore (2, 1)$  satisfy this equation.

$$\therefore (3 + k)(2) + (2 + k)(1) + (-6 + k) = 0$$

$$\therefore 4k + 2 = 0 \quad \therefore k = -\frac{1}{2}$$

$\therefore$  The equation of the required line is

$$(3x + 2y - 6) + \left(-\frac{1}{2}\right)(x + y + 1) = 0$$

$$5x + 3y - 13 = 0$$

**EXERCISE 5.4**

- 1) Find the slope, X-intercept, Y-intercept of each of the following lines.
  - a)  $2x + 3y - 6 = 0$     b)  $3x - y - 9 = 0$
  - c)  $x + 2y = 0$
- 2) Write each of the following equations in  $ax + by + c = 0$  form.
  - a)  $y = 2x - 4$     b)  $y = 4$
  - c)  $\frac{x}{2} + \frac{y}{4} = 1$     d)  $\frac{x}{3} - \frac{y}{2} = 0$
- 3) Show that lines  $x - 2y - 7 = 0$  and  $2x - 4y + 15 = 0$  are parallel to each other.
- 4) Show that lines  $x - 2y - 7 = 0$  and  $2x + y + 1 = 0$  are perpendicular to each other. Find their point of intersection.
- 5) If the line  $3x + 4y = p$  makes a triangle of area 24 square unit with the co-ordinate axes then find the value of  $p$ .
- 6) Find the co-ordinates of the foot of the perpendicular drawn from the point  $A(-2, 3)$  to the line  $3x - y - 1 = 0$ .
- 7) Find the co-ordinates of the circumcenter of the triangle whose vertices are  $A(-2, 3), B(6, -1), C(4, 3)$ .
- 8) Find the co-ordinates of the orthocenter of the triangle whose vertices are  $A(3, -2), B(7, 6), C(-1, 2)$ .
- 9) Show that lines  $3x - 4y + 5 = 0, 7x - 8y + 5 = 0,$  and  $4x + 5y - 45 = 0$  are concurrent. Find their point of concurrence.
- 10) Find the equation of the line whose X-intercept is 3 and which is perpendicular to the line  $3x - y + 23 = 0$ .
- 11) Find the distance of the origin from the line  $7x + 24y - 50 = 0$ .
- 12) Find the distance of the point  $A(-2, 3)$  from the line  $12x - 5y - 13 = 0$ .
- 13) Find the distance between parallel lines  $4x - 3y + 5 = 0$  and  $4x - 3y + 7 = 0$ .
- 14) Find the distance between parallel lines  $9x + 6y - 7 = 0$  and  $3x + 2y + 6 = 0$ .
- 15) Find points on the line  $x + y - 4 = 0$  which are at one unit distance from the line  $x + y - 2 = 0$ .
- 16) Find the equation of the line parallel to the X-axis and passing through the point of intersection of lines  $x + y - 2 = 0$  and  $4x + 3y = 10$ .
- 17) Find the equation of the line passing through the point of intersection of lines  $x + y - 2 = 0$  and  $2x - 3y + 4 = 0$  and making intercept 3 on the X-axis.
- 18) If  $A(4, 3), B(0, 0),$  and  $C(2, 3)$  are the vertices of  $\Delta ABC$  then find the equation of bisector of angle BAC.
- 19)  $D(-1, 8), E(4, -2), F(-5, -3)$  are midpoints of sides BC, CA and AB of  $\Delta ABC$ . Find
  - (i) equations of sides of  $\Delta ABC$ .
  - (ii) co-ordinates of the circumcenter of  $\Delta ABC$ .
- 20)  $O(0, 0), A(6, 0)$  and  $B(0, 8)$  are vertices of a triangle. Find the co-ordinates of the incentre of  $\Delta OAB$ .



### Let's Remember

- **Locus** : A set of points in a plane which satisfy certain geometrical condition (or conditions) is called a locus.
- **Equation of Locus** : Every point in XY plane has Cartesian co-ordinates. An equation which is satisfied by co-ordinates of all points on the locus and which is not satisfied by the co-ordinates of any point which does not lie on the locus is called the equation of the locus.
- **Inclination of a line** : The smallest angle  $\theta$  made by a line with the positive direction of the X-axis, measured in anticlockwise sense, is called the inclination of the line. Clearly  $0^\circ \leq \theta \leq 180^\circ$ .
- **Slope of a line** : If  $\theta$  is the inclination of a line then  $\tan\theta$  (if it exist) is called the slope of the line.

If  $A(x_1, y_1)$ ,  $B(x_2, y_2)$  be any two points on the line whose inclination is  $\theta$  then

$$\tan\theta = \frac{y_2 - y_1}{x_2 - x_1} \quad (\text{if } x_1 \neq x_2)$$

- **Perpendicular and parallel lines** : Lines having slopes  $m_1$  and  $m_2$  are perpendicular to each other if and only if  $m_1 m_2 = -1$ .  
Two lines are parallel if and only if they have the same slope.

- **Angle between intersecting lines** : If  $\theta$  is the acute angle between lines having slopes

$$m_1 \text{ and } m_2 \text{ then } \tan\theta = \left| \frac{m_1 - m_2}{1 + m_1 m_2} \right|$$

- **Equations of line in different forms** :

- **Slope point form** :  $(y - y_1) = m(x - x_1)$

- **Slope intercept form** :  $y = mx + c$

- **Two points form** :  $\frac{x - x_1}{x_2 - x_1} = \frac{y - y_1}{y_2 - y_1}$

- **Double intercept form** :  $\frac{x}{a} + \frac{y}{b} = 1$

- **Normal form** :  $x \cos \alpha + y \sin \alpha = p$

- **General form** :  $ax + by + c = 0$

- **Distance of a point from a line** :

- The distance of the origin from the line

$$ax + by + c = 0 \text{ is given by } p = \left| \frac{c}{\sqrt{a^2 + b^2}} \right|$$

- The distance of the point  $P(x_1, y_1)$  from line  $ax + by + c = 0$  is given by

$$p = \left| \frac{ax_1 + by_1 + c}{\sqrt{a^2 + b^2}} \right|$$

- **The distance between the Parallel lines**

: The distance between the parallel lines  $ax + by + c_1 = 0$  and  $ax + by + c_2 = 0$  is

$$\text{give by } p = \left| \frac{c_1 - c_2}{\sqrt{a^2 + b^2}} \right|$$

**MISCELLANEOUS EXERCISE - 5**

**(I) Select the correct option from the given alternatives.**

- 1) If  $A$  is  $(5, -3)$  and  $B$  is a point on the  $x$ -axis such that the slope of line  $AB$  is  $-2$  then  $B \equiv$ 
  - (A)  $(7, 2)$
  - (B)  $(\frac{7}{2}, 0)$
  - (C)  $(0, \frac{7}{2})$
  - (D)  $(\frac{2}{7}, 0)$
- 2) If the point  $(1, 1)$  lies on the line passing through the points  $(a, 0)$  and  $(0, b)$ , then  $\frac{1}{a} + \frac{1}{b} =$ 
  - (A)  $-1$
  - (B)  $0$
  - (C)  $1$
  - (D)  $\frac{1}{ab}$
- 3) If  $A(1, -2)$ ,  $B(-2, 3)$  and  $C(2, -5)$  are the vertices of  $\Delta ABC$ , then the equation of the median  $BE$  is
  - (A)  $7x + 13y + 47 = 0$
  - (B)  $13x + 7y + 5 = 0$
  - (C)  $7x - 13y + 5 = 0$
  - (D)  $13x - 7y - 5 = 0$
- 4) The equation of the line through  $(1, 2)$ , which makes equal intercepts on the axes, is
  - (A)  $x + y = 1$
  - (B)  $x + y = 2$
  - (C)  $x + y = 4$
  - (D)  $x + y = 5$
- 5) If the line  $kx + 4y = 6$  passes through the point of intersection of the two lines  $2x + 3y = 4$  and  $3x + 4y = 5$ , then  $k =$ 
  - (A)  $1$
  - (B)  $2$
  - (C)  $3$
  - (D)  $4$
- 6) The equation of a line, having inclination  $120^\circ$  with positive direction of  $X$ -axis, which is at a distance of 3 units from the origin is

- (A)  $\sqrt{3}x \pm y + 6 = 0$
  - (B)  $\sqrt{3}x \pm y + 6 = 0$
  - (C)  $x + y = 6$
  - (D)  $x + y = -6$
- 7) A line passes through  $(2, 2)$  and is perpendicular to the line  $3x + y = 3$ . Its  $y$ -intercept is
    - (A)  $\frac{1}{3}$
    - (B)  $\frac{2}{3}$
    - (C)  $1$
    - (D)  $\frac{4}{3}$
  - 8) The angle between the line  $\sqrt{3}x - y - 2 = 0$  and  $x - \sqrt{3}y + 1 = 0$  is
    - (A)  $15^\circ$
    - (B)  $30^\circ$
    - (C)  $45^\circ$
    - (D)  $60^\circ$
  - 9) If  $kx + 2y - 1 = 0$  and  $6x - 4y + 2 = 0$  are identical lines, then determine  $k$ .
    - (A)  $-3$
    - (B)  $-\frac{1}{3}$
    - (C)  $\frac{1}{3}$
    - (D)  $3$
  - 10) Distance between the two parallel lines  $y = 2x + 7$  and  $y = 2x + 5$  is
    - (A)  $\frac{\sqrt{2}}{\sqrt{5}}$
    - (B)  $\frac{1}{\sqrt{5}}$
    - (C)  $\frac{\sqrt{5}}{2}$
    - (D)  $\frac{2}{\sqrt{5}}$

**(II) Answer the following questions.**

- 1) Find the value of  $k$ 
  - a) if the slope of the line passing through the points  $P(3, 4)$ ,  $Q(5, k)$  is 9.
  - b) the points  $A(1, 3)$ ,  $B(4, 1)$ ,  $C(3, k)$  are collinear
  - c) the point  $P(1, k)$  lies on the line passing through the points  $A(2, 2)$  and  $B(3, 3)$ .
- 2) Reduce the equation  $6x + 3y + 8 = 0$  into slope-intercept form. Hence find its slope.
- 3) Find the distance of the origin from the line  $x = -2$ .
- 4) Does point  $A(2, 3)$  lie on the line  $3x + 2y - 6 = 0$  ? Give reason.

- 5) Which of the following lines passes through the origin ?
- (a)  $x = 2$                       (b)  $y = 3$   
(c)  $y = x + 2$                   (d)  $2x - y = 0$
- 6) Obtain the equation of the line which is :
- a) parallel to the X-axis and 3 unit below it.  
b) parallel to the Y-axis and 2 unit to the left of it.  
c) parallel to the X-axis and making an intercept of 5 on the Y-axis.  
d) parallel to the Y-axis and making an intercept of 3 on the X-axis.
- 7) Obtain the equation of the line containing the point
- (i) (2,3) and parallel to the X-axis.  
(ii) (2,4) and perpendicular to the Y-axis.
- 8) Find the equation of the line :
- a) having slope 5 and containing point A(-1,2).  
b) containing the point T(7,3) and having inclination  $90^\circ$ .  
c) through the origin which bisects the portion of the line  $3x + 2y = 2$  intercepted between the co-ordinate axes.
- 9) Find the equation of the line passing through the points S(2,1) and T(2,3)
- 10) Find the distance of the origin from the line  $12x + 5y + 78 = 0$
- 11) Find the distance between the parallel lines  $3x + 4y + 3 = 0$  and  $3x + 4y + 15 = 0$
- 12) Find the equation of the line which contains the point A(3,5) and makes equal intercepts on the co-ordinates axes.
- 13) The vertices of a triangle are A(1,4), B(2,3) and C(1,6). Find equations of
- (a) the sides                      (b) the medians  
(c) Perpendicular bisectors of sides  
(d) altitudes of  $\Delta ABC$ .
- 14) Find the equation of the line which passes through the point of intersection of lines  $x + y - 3 = 0$ ,  $2x - y + 1 = 0$  and which is parallel X-axis.
- 15) Find the equation of the line which passes through the point of intersection of lines  $x + y + 9 = 0$ ,  $2x + 3y + 1 = 0$  and which makes X-intercept 1.
- 16) Find the equation of the line through A(-2,3) and perpendicular to the line through S(1,2) and T(2,5).
- 17) Find the X-intercept of the line whose slope is 3 and which makes intercept 4 on the Y-axis.
- 18) Find the distance of P(-1,1) from the line  $12(x + 6) = 5(y - 2)$ .
- 19) Line through A(h,3) and B(4,1) intersect the line  $7x - 9y - 19 = 0$  at right angle. Find the value of h.
- 20) Two lines passing through M(2,3) intersect each other at an angle of  $45^\circ$ . If slope of one line is 2, find the equation of the other line.
- 21) Find the Y-intercept of the line whose slope is 4 and which has X intercept 5.

- 22) Find the equations of the diagonals of the rectangle whose sides are contained in the lines  $x = 8$ ,  $x = 10$ ,  $y = 11$  and  $y = 12$ .
- 23) A(1, 4), B(2,3) and C (1, 6) are vertices of  $\Delta ABC$ . Find the equation of the altitude through B and hence find the co-ordinates of the point where this altitude cuts the side AC of  $\Delta ABC$ .
- 24) The vertices of  $\Delta PQR$  are  $P(2,1)$ ,  $Q(-2,3)$  and  $R(4,5)$ . Find the equation of the median through R.
- 25) A line perpendicular to segment joining A (1,0) and B(2,3) divides it internally in the ratio 1:2. Find the equation of the line.
- 26) Find the co-ordinates of the foot of the perpendicular drawn from the point P (-1,3) to the line  $3x - 4y - 16 = 0$ .
- 27) Find points on the X-axis whose distance from the line  $\frac{x}{3} + \frac{y}{4} = 1$  is 4 unit.
- 28) The perpendicular from the origin to a line meets it at (-2,9). Find the equation of the line.
- 29) P(a,b) is the mid point of a line segment between axes. Show that the equation of the line is  $\frac{x}{a} + \frac{y}{b} = 2$ .
- 30) Find the distance of the line  $4x - y = 0$  from the point P(4,1) measured along the line making an angle of  $135^\circ$  with the positive X-axis.
- 31) Show that there are two lines which pass through A(3,4) and the sum of whose intercepts is zero.
- 32) Show that there is only one line which passes through B(5,5) and the sum of whose intercept is zero.



# 6 Circle

## Let's Study

- Equation of a circle and its different forms
- Equation of Tangent to a circle
- Condition for tangency
- Director circle

## Let's Recall

- Properties of chords and tangents of a circle.
- The angle inscribed in a semicircle is a right angle.
- Product of slopes of perpendicular lines is -1.
- Slopes of parallel lines are equal.

A circle is a set of all points in a plane which are equidistant from a fixed point in the plane.

The fixed point is called the centre of the circle and the distance from the centre to any point on the circle is called the radius of the circle.

### 6.1 Different forms of equation of a circle

**(1) Standard form :** In Fig. 6.1, the origin, O

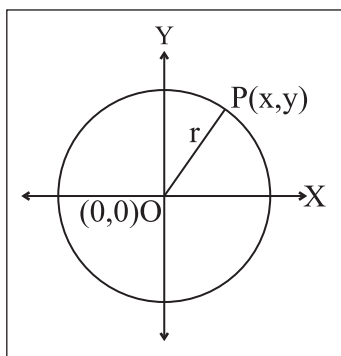

Fig. 6.1

is the centre of the circle. P(x, y) is any point on the circle. The radius of circle is r.

$$\therefore OP = r.$$

By distance formula

$$OP^2 = (x-0)^2 + (y-0)^2$$

$$\therefore \text{we get } r^2 = x^2 + y^2$$

$$\therefore x^2 + y^2 = r^2.$$

This is the standard equation of a circle.

### (2) Centre-radius form :

In Fig. 6.2, C(h, k) is the centre and r is the radius of the circle. P(x, y) is any point on the circle.

$$\therefore CP = r$$

Also,

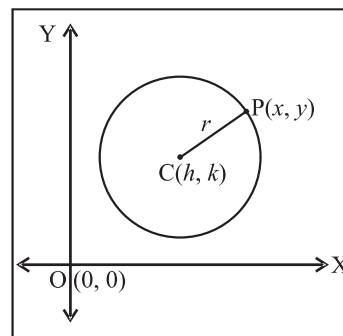

Fig. 6.2

$$CP = \sqrt{(x-h)^2 + (y-k)^2} \therefore r^2 = (x-h)^2 + (y-k)^2$$

$(x-h)^2 + (y-k)^2 = r^2$  is the centre-radius form of equation of a circle.

**(3) Diameter Form :** In the Fig. 6.3, C is the centre of the circle.

A(x<sub>1</sub>, y<sub>1</sub>), B(x<sub>2</sub>, y<sub>2</sub>) are the end points of a diameter of the circle. P(x, y) is any point on the circle.

Angle inscribed in a semi circle is a right

angle; hence,  $\angle APB = 90^\circ$ ; that is  $AP \perp BP$ .

$$\text{Slope of AP} = \frac{y-y_1}{x-x_1} \text{ and slope of BP} = \frac{y-y_2}{x-x_2},$$

As  $AP \perp BP$ , product of their slopes is -1.

$$\therefore \frac{y-y_1}{x-x_1} \times \frac{y-y_2}{x-x_2} = -1$$

$$(y-y_1)(y-y_2) = -(x-x_1)(x-x_2)$$

$$(x-x_1)(x-x_2) + (y-y_1)(y-y_2) = 0$$

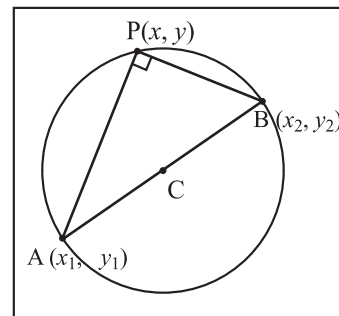

Fig. 6.3

That is,  $(x - x_1)(x - x_2) + (y - y_1)(y - y_2) = 0$

This is called the diameter form of the equation of circle, where  $(x_1, y_1)$  and  $(x_2, y_2)$  are endpoints of diameter of the circle.

### SOLVED EXAMPLES

**Ex.1** Find the equation of a circle with centre at origin and radius 3.

**Solution :** Standard equation of a circle is

$$x^2 + y^2 = r^2 \quad \text{here } r = 3$$

$$\therefore x^2 + y^2 = 3^2$$

$$x^2 + y^2 = 9 \quad \text{is the equation of circle}$$

**Ex.2** Find the equation of a circle whose centre is  $(-3, 1)$  and which pass through the point  $(5, 2)$ .

**Solution :** Centre  $C = (-3, 1)$ ,

Circle passes through the point  $P(5, 2)$ .

By distance formula,

$$\begin{aligned} r^2 = CP^2 &= (5 + 3)^2 + (2 - 1)^2 \\ &= 8^2 + 1^2 = 64 + 1 = 65 \end{aligned}$$

$\therefore$  the equation of the circle is

$$(x + 3)^2 + (y - 1)^2 = 65 \quad \text{(centre-radius form)}$$

$$x^2 + 6x + 9 + y^2 - 2y + 1 = 65$$

$$x^2 + y^2 + 6x - 2y + 10 - 65 = 0$$

$$x^2 + y^2 + 6x - 2y - 55 = 0$$

**Ex.3** Find the equation of the circle with  $A(2, -3)$  and  $B(-3, 5)$  as end points of its diameter.

**Solution :** By using the diameter form;

$A(2, -3) \equiv (x_1, y_1)$  and  $B(-3, 5) \equiv (x_2, y_2)$  are the co-ordinates of the end points of a diameter of the circle.

$\therefore$  by the diameter form, equation of the circle is

$$(x - x_1)(x - x_2) + (y - y_1)(y - y_2) = 0$$

$$\therefore (x - 2)(x + 3) + (y + 3)(y - 5) = 0$$

$$\therefore x^2 + x - 6 + y^2 - 2y - 15 = 0$$

$$\therefore x^2 + y^2 + x - 2y - 21 = 0$$

**Ex.4** Find the equation of circle touching the Y-axis at point  $(0, 3)$  and whose Centre is at  $(-3, 3)$ .

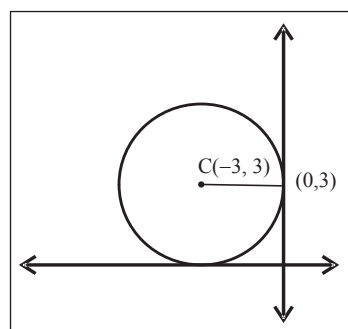

Fig. 6.4

**Solution :**

The circle touches the Y-axis at point  $(0, 3)$ , and the centre is  $(-3, 3)$  we get radius  $r = 3$

By using centre radius form;

$$(x - h)^2 + (y - k)^2 = r^2$$

$$(x + 3)^2 + (y - 3)^2 = 9$$

$$x^2 + 6x + 9 + y^2 - 6y + 9 = 9$$

$\therefore x^2 + y^2 + 6x - 6y + 9 = 0$  is the equation of the circle.

**Ex.5** Find the equation of the circle whose centre is at  $(3, -4)$  and the line  $3x - 4y - 5 = 0$  cuts the circle at A and B; where  $l(AB) = 6$ .

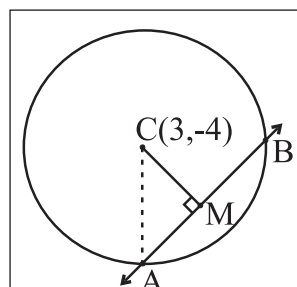

Fig. 6.5

**Solution :** centre of the circle  $C(h, k) = C(3, -4)$

$3x - 4y - 5 = 0$  cuts the circle at A and B.

$$l(AB) = 6$$

$$CM \perp AB$$

$$\therefore AM = BM = 3$$

CM = Length of perpendicular from centre on the line

$$= \left| \frac{3(3) - 4(-4) - 5}{\sqrt{(3)^2 + (-4)^2}} \right|$$

$$= \left| \frac{9 + 16 - 5}{\sqrt{9 + 16}} \right|$$

$$= \left| \frac{20}{5} \right| = 4$$

From right angled triangle AMC

$$CA^2 = CM^2 + AM^2$$

$$= (4)^2 + (3)^2$$

$$= 16 + 9 = 25$$

CA = radius of the circle = 5

By centre radius form equation of the circle.

$$(x - 3)^2 + (y + 4)^2 = 5^2$$

$$x^2 - 6x + 9 + y^2 + 8y + 16 = 25$$

$$x^2 + y^2 - 6x + 8y = 0$$

### EXERCISE 6.1

- Find the equation of the circle with
  - Centre at origin and radius 4.
  - Centre at  $(-3, -2)$  and radius 6.
  - Centre at  $(2, -3)$  and radius 5.
  - Centre at  $(-3, -3)$  passing through point  $(-3, -6)$
- Find the centre and radius of the circle.
  - $x^2 + y^2 = 25$
  - $(x - 5)^2 + (y - 3)^2 = 20$
  - $\left(x - \frac{1}{2}\right)^2 + \left(y + \frac{1}{3}\right)^2 = \frac{1}{36}$
- Find the equation of the circle with centre
  - At  $(a, b)$  touching the Y-axis
  - At  $(-2, 3)$  touching the X-axis
  - on the X-axis and passing through the origin having radius 4.
  - at  $(3, 1)$  and touching the line  $8x - 15y + 25 = 0$
- Find the equation circle if the equations of two diameters are  $2x + y = 6$  and  $3x + 2y = 4$ . When radius of circle is 9.

- If  $y = 2x$  is a chord of circle  $x^2 + y^2 - 10x = 0$ , find the equation of circle with this chord as diameter.
- Find the equation of a circle with radius 4 units and touching both the co-ordinate axes having centre in third quadrant.
- Find the equation of circle (a) passing through the origin and having intercepts 4 and  $-5$  on the co-ordinate axes.
- Find the equation of a circle passing through the points  $(1, -4)$ ,  $(5, 2)$  and having its centre on the line  $x - 2y + 9 = 0$ .

### Activity :

- Construct a circle in fourth quadrant having radius 3 and touching Y-axis. How many such circles can be drawn?
- Construct a circle whose equation is  $x^2 + y^2 - 4x + 6y - 12 = 0$ . Find the area of the circle.

### 6.2 General equation of a circle :

**The general equation of a circle is of the form  $x^2 + y^2 + 2gx + 2fy + c = 0$ , if  $g^2 + f^2 - c > 0$**

The centre-radius form of equation of a circle is

$$(x - h)^2 + (y - k)^2 = r^2$$

i.e.  $x^2 - 2hx + h^2 + y^2 - 2ky + k^2 = r^2$

i.e.  $x^2 + y^2 - 2hx - 2ky + (h^2 + k^2 - r^2) = 0$

If this is the same as equation  $x^2 + y^2 + 2gx + 2fy + c = 0$ , then comparing the coefficients

$2g = -2h, 2f = -2k$  and  $c = h^2 + k^2 - r^2$ .

$\therefore (h, k) \equiv (-g, -f)$  is the center and

$r^2 = h^2 + k^2 - c$  i.e.  $r = \sqrt{g^2 + f^2 - c}$  is the radius.

Thus,

the general equation of a circle is  $x^2 + y^2 + 2gx + 2fy + c = 0$  whose centre is  $(-g, -f)$  and radius is  $\sqrt{g^2 + f^2 - c}$ .

**Activity :**

Consider the general equation of a circle

$$x^2 + y^2 + 2gx + 2fy + c = 0$$

$$x^2 + 2gx + \square + y^2 + 2fy + \square = \square + \square - c$$

$$\therefore (x + \square)^2 + (y + \square)^2 = g^2 + f^2 - c.$$

$$\therefore [x - (\quad)]^2 + [y - (\quad)]^2 = (\quad)^2$$

(use centre radius form of equation of the circle).

Therefore centre of the circle is  $(-g, -f)$  and radius is  $\sqrt{g^2 + f^2 - c}$ .



**Let's Remember**

- (1) If  $g^2 + f^2 - c > 0$ , the equation  $x^2 + y^2 + 2gx + 2fy + c = 0$  represents a circle in the  $xy$  plane.
- (2) If  $g^2 + f^2 - c = 0$ , then the equation  $x^2 + y^2 + 2gx + 2fy + c = 0$  represents a point which is true degenerate conic and is the limiting position (radius is 0).
- (3) If  $g^2 + f^2 - c < 0$ , then the equation  $x^2 + y^2 + 2gx + 2fy + c = 0$  does not represent any point in the  $xy$  plane.

**Activity :**

Check whether the following equations represent a circle. If, so then find its centre and radius.

- a)  $x^2 + y^2 - 6x - 4y + 9 = 0$
- b)  $x^2 + y^2 - 8x + 6y + 29 = 0$
- c)  $x^2 + y^2 + 7x - 5y + 15 = 0$

**Lets Note :**

The general equation of a circle is a second degree equation in  $x$  and  $y$ , coefficient of  $xy$  is zero, coefficient of  $x^2 =$  coefficient of  $y^2$

**SOLVED EXAMPLES**

**Ex. 1)** Prove that  $3x^2 + 3y^2 - 6x + 4y - 1 = 0$ , represents a circle. Find its centre and radius.

**Solution :** Given equation is

$$3x^2 + 3y^2 - 6x + 4y - 1 = 0$$

dividing by 3, we get

$$x^2 + y^2 - 2x + \frac{4y}{3} - \frac{1}{3} = 0 \text{ comparing this with}$$

$$x^2 + y^2 + 2gx + 2fy + c = 0$$

$$\text{we get } 2g = -2 \quad \therefore g = -1$$

$$2f = \frac{4}{3} \quad \therefore f = \frac{2}{3} \text{ and } c = -\frac{1}{3}$$

$$g^2 + f^2 - c = (-1)^2 + \left(\frac{2}{3}\right)^2 - \frac{-1}{3}$$

$$= 1 + \frac{4}{9} + \frac{1}{3} = \frac{16}{9}$$

$$\text{As } \frac{16}{9} > 0 \quad g^2 + f^2 - c > 0$$

$\therefore 3x^2 + 3y^2 - 6x + 4y - 1 = 0$  represents a circle.

$$\therefore \text{Centre of the circle} = (-g, -f) = \left(1, \frac{-2}{3}\right)$$

$$\text{Radius of circle } r = \sqrt{(-g)^2 + (-f)^2 - c}$$

$$= \sqrt{\frac{16}{9}} = \frac{4}{3}$$

**Ex. 2)** Find the equation of the circle passing through the points  $(5, -6)$ ,  $(1, 2)$  and  $(3, -4)$ .

**Solution :** Consider  $P = (5, -6)$ ,  $Q = (1, 2)$ ,

$$R = (3, -4)$$

Let the centre of the circle be at  $C(h, k)$

$$\therefore r = CP = CQ = CR = \text{radii of the same circle}$$

Consider  $CP = CQ$

$$\therefore CP^2 = CQ^2$$

By using distance formula,

$$(h - 5)^2 + (k + 6)^2 = (h - 1)^2 + (k - 2)^2$$

$$\therefore h^2 - 10h + 25 + k^2 + 12k + 36$$

$$= h^2 - 2h + 1 + k^2 - 4k + 4$$

$$\text{i.e. } -8h + 16k = -56$$

$$h - 2k = 7 \quad \dots\dots (I)$$

Now consider,  $CQ = CR \quad \therefore CQ^2 = CR^2$

$$(h - 1)^2 + (k - 2)^2 = (h - 3)^2 + (k + 4)^2$$

$$\therefore h^2 - 2h + 1 + k^2 - 4k + 4$$

$$= h^2 - 6h + 9 + k^2 + 8k + 16$$

$$\text{i.e. } 4h - 12k = 20 \quad \therefore h - 3k = 5 \quad \dots\dots (II)$$

Now, subtracting (II) from I, we get,

$$k = 2$$

Substituting  $k = 2$  in (II) we get

$$h = 11 \quad \therefore C = (11, 2)$$

Radius of the circle is

$$r = |CP| = \sqrt{(11-5)^2 + (2+6)^2} = \sqrt{100} = 10;$$

By using centre-radius form, equation of the circle is  $(x - 11)^2 + (y - 2)^2 = 100$

$$\therefore x^2 - 22x + 121 + y^2 - 4y + 4 = 100$$

$$\therefore x^2 + y^2 - 22x - 4y + 25 = 0$$

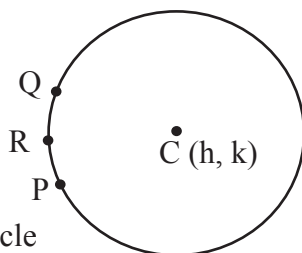

Fig. 6.6

**Ex. 3** Show that the points  $(5, 5)$ ,  $(6, 4)$ ,  $(-2, 4)$  and  $(7, 1)$  are on the same circle; i.e. these points are concyclic.

**Solution :**

Let, the equation of the circle be

$$x^2 + y^2 + 2gx + 2fy + c = 0 \quad \dots\dots (I)$$

The circle passing through  $(5, 5)$ ,  $(6, 4)$ ,  $(-2, 4)$

$$\therefore 50 + 10g + 10f + c = 0 \quad \dots\dots (II)$$

$$\therefore 52 + 12g + 8f + c = 0 \quad \dots\dots (III)$$

$$\therefore 20 - 4g + 8f + c = 0 \quad \dots\dots (IV)$$

Now (III) - (IV) gives  $32 + 16g = 0$

$$\therefore 16g = -32 \quad \therefore g = -2$$

Subtracting (II) from (III)

$$\text{we get } 2 + 2g - 2f = 0 \quad \dots\dots (V)$$

substitute  $g = -2$  in equation (V)

$$2 + (-4) - 2f = 0 \quad 2 - 4 = 2f \quad \therefore f = -1$$

Now substitute  $g = -2$  and  $f = -1$  in eqn. (IV)

$$20 + c = 4(-2) - 8(1) = -8 + 8$$

$$20 + c = 0 \quad \therefore c = -20$$

Now substituting  $g = -2, f = -1$  and  $c = -20$  in equation (I) we get,

$$x^2 + y^2 - 4x - 2y - 20 = 0 \quad \dots\dots (VI) \text{ is the equation of the circle passing through the points } (5,5), (6,4) \text{ and } (-2,4).$$

If  $(7,1)$  satisfies equation (VI), the four points are concyclic.

$$\begin{aligned} \text{L.H.S.} &= (7)^2 + (1)^2 - 28 - 2 - 20 \\ &= 49 + 1 - 50 = 0 = \text{R.H.S.} \end{aligned}$$

$\therefore$  Thus, the point  $(7, 1)$  satisfies the equation of circle.

$\therefore$  The given points are concyclic .

**EXERCISE 6.2**

- (1) Find the centre and radius of each of the following.
  - (i)  $x^2 + y^2 - 2x + 4y - 4 = 0$
  - (ii)  $x^2 + y^2 - 6x - 8y - 24 = 0$
  - (iii)  $4x^2 + 4y^2 - 24x - 8y - 24 = 0$
- (2) Show that the equation  $3x^2 + 3y^2 + 12x + 18y - 11 = 0$  represents a circle.
- (3) Find the equation of the circle passing through the points (5, 7), (6, 6) and (2, -2).
- (4) Show that the points (3, -2), (1, 0), (-1, -2) and (1, -4) are concyclic.

**6.3 Parametric Form of a circle :**

Let P(x, y) be any point on a circle with centre at O and radius r.

As shown in Fig. 6.7, OP makes an angle  $\theta$  with the positive direction of X-axis. Draw  $PM \perp X$ -axis from P.

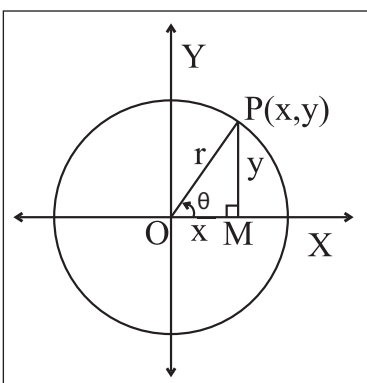

**Fig. 6.7**

$\Delta OMP$  is a right angled triangle,

$$\therefore \cos \theta = \frac{OM}{OP} = \frac{x}{r} ; \quad \sin \theta = \frac{PM}{OP} = \frac{y}{r}$$

$$\therefore x = r \cos \theta \quad \therefore y = r \sin \theta$$

$x = r \cos \theta$  and  $y = r \sin \theta$  is the parametric form of circle  $x^2 + y^2 = r^2$ .  $\theta$  is called parameter.

**Note that:**

- (1) The parametric form of circle  $(x - h)^2 + (y - k)^2 = r^2$  is given by

$$x = h + r \cos \theta \text{ and } y = k + r \sin \theta.$$

Hence co-ordinates of any point on the circle are  $(h + r \cos \theta, k + r \sin \theta)$ .

- (2) Sometimes parametric form is more convenient for calculation as it contains only one variable.

**6.3.1 Tangent :** When a line intersects a circle in coincident points, then that line is called as a tangent of the circle and the point of intersection is called point of contact.

**The equation of tangent to a standard circle  $x^2 + y^2 = r^2$  at point  $P(x_1, y_1)$  on it.**

Given equation of a circle is  $x^2 + y^2 = r^2$ . The centre of the circle is at origin  $O(0, 0)$  and radius is  $r$ . Let  $P(x_1, y_1)$  be any point on the circle.

$$\text{Slope of } OP = \frac{y_1 - 0}{x_1 - 0} = \frac{y_1}{x_1}, \text{ if } x_1 \neq 0, y_1 \neq 0.$$

A tangent is drawn to the circle at point P.

Since  $OP$  is perpendicular to tangent at point P.

slope of the tangent

$$m = \frac{-x_1}{y_1}$$

$\therefore$  equation of the tangent in slope point form is

$$y - y_1 = m(x - x_1)$$

$$y - y_1 = \frac{-x_1}{y_1} (x - x_1)$$

$$yy_1 - y_1^2 = -xx_1 + x_1^2$$

$$xx_1 + yy_1 = x_1^2 + y_1^2 \dots\dots\dots(I)$$

As  $(x_1, y_1)$  lies on the circle,  $x_1^2 + y_1^2 = r^2$ , therefore equation (I) becomes  $xx_1 + yy_1 = r^2$

Thus, In general, equation of the tangent to a circle  $x^2 + y^2 = r^2$  at point  $P(x_1, y_1)$  is  $xx_1 + yy_1 = r^2$

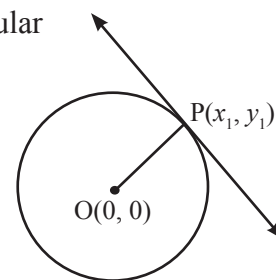

**Fig. 6.8**

Follow the method given above and verify that equation of tangent to the circle  $x^2 + y^2 + 2gx + 2fy + c = 0$  at  $(x_1, y_1)$  is  $xx_1 + yy_1 + g(x+x_1) + f(y+y_1) + c = 0$

To find equation of tangent to the curve at  $(x_1, y_1)$  replace  $x^2$  by  $xx_1$ ,  $2x$  by  $(x + x_1)$ ,  $y^2$  by  $yy_1$ ,  $2y$  by  $(y + y_1)$

**Equation of tangent in parametric form.**

Substituting  $r \cos \theta_1$  for  $x_1$  and  $r \sin \theta_1$  for  $y_1$ , the equation of a tangent to the circle  $x^2 + y^2 = r^2$  at point  $P(r \cos \theta_1, r \sin \theta_1) = (x_1, y_1)$  is  $x \cdot r \cos \theta_1 + y \cdot r \sin \theta_1 = r^2$  i.e.  $x \cos \theta_1 + y \sin \theta_1 = r$

**6.3.2 Condition of tangency :**

To find the condition that a line  $y = mx + c$  is a tangent to the circle  $x^2 + y^2 = a^2$  and also to find the point of contact,

Let the equation of the line be  $y = mx + c$

$$\therefore mx - y + c = 0 \quad \dots\dots\dots(I)$$

Equation of a tangent to the circle  $x^2 + y^2 = a^2$  at point  $(x_1, y_1)$  on it is  $xx_1 + yy_1 = a^2$

$$\text{i.e. } x_1 x + y_1 y - a^2 = 0 \quad \dots\dots\dots(II)$$

If the line given by equation (I) is tangent to the circle then equation (I) and equation (II) represent the same (tangent) line.

Comparing the co-efficients of the like terms in these equations,

$$\frac{x_1}{m} = \frac{y_1}{-1} = \frac{-a^2}{c}$$

$$\therefore \frac{x_1}{m} = \frac{-a^2}{c} \text{ and } \frac{y_1}{-1} = \frac{-a^2}{c}$$

$$\therefore x_1 = \frac{-a^2 m}{c} \text{ and } y_1 = \frac{a^2}{c}$$

But the point  $(x_1, y_1)$  lies on the circle

$$\therefore x_1^2 + y_1^2 = a^2$$

$$\therefore \left(\frac{-a^2 m}{c}\right)^2 + \left(\frac{a^2}{c}\right)^2 = a^2$$

$$\frac{a^4 m^2}{c^2} + \frac{a^4}{c^2} = a^2$$

$$a^2 m^2 + a^2 = c^2. \quad \text{i.e. } c^2 = a^2 m^2 + a^2,$$

which is the required condition of tangency

and the point of contact  $P(x_1, y_1) \equiv \left(\frac{-a^2 m}{c}, \frac{a^2}{c}\right)$ .

Thus a line  $y = mx + c$  is a tangent to the circle  $x^2 + y^2 = a^2$ , if  $c^2 = a^2 m^2 + a^2$  i.e.  $c = \pm \sqrt{a^2 m^2 + a^2}$  and the point of contact is  $\left(\frac{-a^2 m}{c}, \frac{a^2}{c}\right)$ .

Thus, there are two tangents with the same slope  $m$ ,  $y = mx + \sqrt{a^2(1+m^2)}$ ,  $y = mx - \sqrt{a^2(1+m^2)}$

To check the tangency of a straight line to a circle, it is enough to show that the perpendicular from the center to the line is equal to the radius.

**6.3.3 Tangents from a point to the circle**

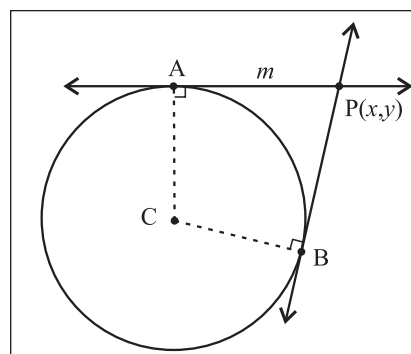

**Fig. 6.9**

From any point outside the circle and in the same plane, two tangents can be drawn to the circle.

Let  $P(x_1, y_1)$  be a point in the plane, outside the circle.

If a tangent from  $P$  to the circle has slope  $m$ , the equation of the tangent is  $y - y_1 = m(x - x_1)$  i.e.  $mx - y_1 - mx_1 + y_1 = 0$ .

The condition that this is tangent to the circle is  $\frac{|y_1 - mx_1|}{\sqrt{1+m^2}} = a$ , the radius.

$$\therefore (y_1 - mx_1)^2 = a^2(1+m^2)$$

$$\therefore x^2 - 2x_1y_1m + x_1^2m^2 = a^2 + a^2m^2$$

$\therefore (x_1^2 - a^2)m^2 - 2x_1y_1m + (y_1^2 - a^2) = 0$  is quadratic equation in  $m$ .

It has two roots say  $m_1$  and  $m_2$ , which are the slopes of two tangents.

Thus two tangents can be drawn to a circle from a given point in its plane.

$$\begin{aligned} \text{Sum of the roots } (m_1 + m_2) &= \frac{-(-2x_1y_1)}{(x_1^2 - a^2)} \\ &= \frac{2x_1y_1}{x_1^2 - a^2} \end{aligned}$$

$$\text{Product of the roots } (m_1 m_2) = \frac{(y_1^2 - a^2)}{(x_1^2 - a^2)}$$

### 6.3.4 Director Circle:

The locus of the point of intersection of perpendicular tangents to a circle

If the tangents drawn from a point P are mutually perpendicular to each other then  $m_1 m_2 = -1$  and we have,

$$\frac{y_1^2 - a^2}{x_1^2 - a^2} = -1$$

$$\therefore y_1^2 - a^2 = -(x_1^2 - a^2)$$

$$\therefore y_1^2 - a^2 = -x_1^2 + a^2$$

$$\therefore x_1^2 + y_1^2 = a^2 + a^2$$

$$\therefore x_1^2 + y_1^2 = 2a^2.$$

Which represents a circle and is called as equation of the director circle of the circle

$$x^2 + y^2 = a^2.$$

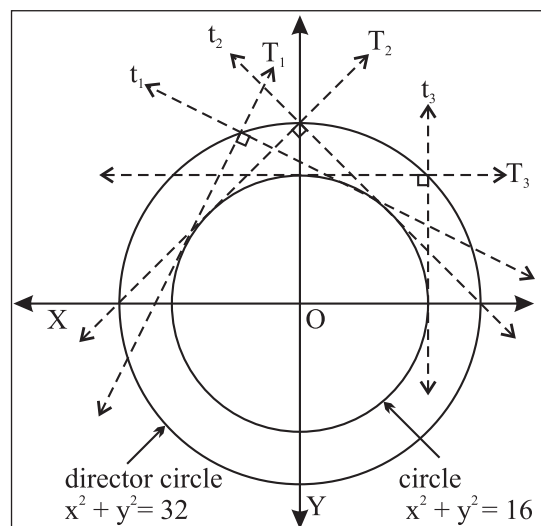

Fig. 6.10

### SOLVED EXAMPLES

**Ex. 1)** Find the parametric equation of the circle  $x^2 + y^2 - 6x + 4y - 3 = 0$

**Solution :** We write the equation of the circle as

$$(x^2 - 6x + 9) + (y^2 + 4y + 4) = 3 + 9 + 4$$

$$(x - 3)^2 + (y + 2)^2 = 16$$

$$(x - 3)^2 + (y + 2)^2 = (4)^2$$

The parametric equations are

$$x - 3 = 4 \cos \theta \text{ and } y + 2 = 4 \sin \theta$$

$$\text{that is, } x = 3 + 4 \cos \theta \text{ and } y = -2 + 4 \sin \theta$$

**Ex. 2)** Show that the line  $3x - 4y + 15 = 0$  is a tangent to the circle  $x^2 + y^2 = 9$ . Find the point of contact.

**Solution :** The equation of circle is  $x^2 + y^2 = 9$  ... (1)

The equation of line is  $3x - 4y + 15 = 0$  ... (2)

$\therefore y = \frac{1}{4} (3x + 15)$ , substitute value of  $y$  in equation (1)

$$x^2 + \frac{1}{16} (3x + 15)^2 = 9$$

$$\begin{aligned} \therefore 16x^2 + 9x^2 + 90x + 225 &= 144 \\ \therefore 25x^2 + 90x + 81 &= 0 \\ \therefore (5x + 9)^2 &= 0 \\ x &= \frac{-9}{5}; \text{ The roots of equation are equal.} \end{aligned}$$

$\therefore$  line (2) is tangent to given circle (1)

$$\begin{aligned} \therefore y &= \frac{1}{4} (3x + 15) \\ &= \frac{1}{4} \left( 3 \left( -\frac{9}{5} \right) + 15 \right) \\ &= \frac{12}{5} \end{aligned}$$

$\left( -\frac{9}{5}, \frac{12}{5} \right)$  is the only point of intersection of the line and circle.

$\therefore$  The line  $3x - 4y + 15 = 0$  touches the circle at  $\left( -\frac{9}{5}, \frac{12}{5} \right)$

$$\therefore \text{ point of contact} = \left( -\frac{9}{5}, \frac{12}{5} \right)$$

### Activity :

Equation of a circle is  $x^2 + y^2 = 9$ .

Its centre is at  $(\square, \square)$  and radius is  $\square$

Equation of a line is  $3x - 4y + 15 = 0$

$$\therefore y = \square x + \square$$

Comparing it with  $y = mx + c$

$$m = \square \text{ and } c = \square$$

We know that, if the line  $y = mx + c$  is a tangent to  $x^2 + y^2 = a^2$  then  $c^2 = a^2m^2 + a^2$

$$\begin{aligned} \text{Hence } c^2 &= (\square)^2 & \text{Also, } c^2 &= a^2m^2 + a^2 \\ &= \frac{225}{16} \dots (I) & &= 9\square + 9 \\ & & &= 9\left(\frac{9}{16} + 1\right) \\ & & &= \frac{9(25)}{16} \\ & & &= \frac{225}{16} \dots\dots\dots(II) \end{aligned}$$

From equations (I) and (II) we conclude that

**Ex. 3)** Find the equation of the tangent to the circle  $x^2 + y^2 - 4x - 6y - 12 = 0$  at  $(-1, -1)$

**Solution :** The equation of circle is

$$x^2 + y^2 - 4x - 6y - 12 = 0$$

It is of the type  $x^2 + y^2 + 2gx + 2fy + c = 0$

$$\therefore g = -2, f = -3, c = -12$$

Let  $P(-1, -1) = (x_1, y_1)$

We know that the equation of a tangent to a circle

$$x^2 + y^2 + 2gx + 2fy + c = 0 \text{ at } (x_1, y_1) \text{ is}$$

$$xx_1 + yy_1 + g(x + x_1) + f(y + y_1) + c = 0$$

$$x(-1) + y(-1) + 2(x-1) - 3(y-1) - 12 = 0$$

$$-x - y - 2x + 2 - 3y + 3 - 12 = 0$$

$$3x + 4y + 7 = 0$$

### EXERCISE 6.3

- (1) Write the parametric equations of the circles
  - (i)  $x^2 + y^2 = 9$
  - (ii)  $x^2 + y^2 + 2x - 4y - 4 = 0$
  - (iii)  $(x - 3)^2 + (y + 4)^2 = 25$
- (2) Find the parametric representation of the circle  $3x^2 + 3y^2 - 4x + 6y - 4 = 0$ .
- (3) Find the equation of a tangent to the circle  $x^2 + y^2 - 3x + 2y = 0$  at the origin.
- (4) Show that the line  $7x - 3y - 1 = 0$  touches the circle  $x^2 + y^2 + 5x - 7y + 4 = 0$  at point  $(1, 2)$
- (5) Find the equation of tangent to the circle  $x^2 + y^2 - 4x + 3y + 2 = 0$  at the point  $(4, -2)$



**Let's Remember**

- 1) Equation of a standard circle is  $x^2 + y^2 = r^2$ .  
Its centre is at  $(0, 0)$  and radius is  $r$ .
- 2) Equation of a circle in (centre-radius) form is  
 $(x - h)^2 + (y - k)^2 = r^2$   
Its centre is at  $(h, k)$  and radius is  $r$ .
- 3) Equation of a circle in general form is  
 $x^2 + y^2 + 2gx + 2fy + c = 0$ .  
Its centre is at  $(-g, -f)$  and radius is  $\sqrt{g^2 + f^2 - c}$   
If  $g^2 + f^2 > c$  then the circle is real, it can be drawn in the  $xy$  plane.  
If  $g^2 + f^2 = c$  then the circle reduces to a point.  
If  $g^2 + f^2 < c$  then the circle is not real and it cannot be drawn in  $xy$  plane.
- 4) Equation of a standard circle  $x^2 + y^2 = r^2$  in parametric form is  $x = r\cos\theta$   $y = r\sin\theta$ .
- 5) Equation of a tangent to the circle  $x^2 + y^2 = r^2$  at point  $(x_1, y_1)$  on it is  $xx_1 + yy_1 = r^2$  in the Cartesian form and point of contact is  $\left(\frac{-r^2m}{c}, \frac{r^2}{c}\right)$ . Equation of a tangent in parametric form to the circle  $x^2 + y^2 = r^2$  at point  $P(x_1, y_1) \equiv P(\theta_1)$ , where  $\theta_1$  is the parameter, is  $\cos\theta_1 x + \sin\theta_1 y = r$  is.
- 6) A line  $y = mx + c$  is a tangent to the circle  $x^2 + y^2 = r^2$  if and only if  $c^2 = r^2m^2 + r^2$ .
- 7) Equation of a tangent line in terms of slope is  $y = mx \pm \sqrt{r^2m^2 + r^2}$ .
- 8) Equation of director circle of circle  $x^2 + y^2 = r^2$  is  $x^2 + y^2 = 2r^2$ .

**MISCELLANEOUS EXERCISE - 6**

**(I) Choose the correct alternative.**

- (1) Equation of a circle which passes through  $(3, 6)$  and touches the axes is  
(A)  $x^2 + y^2 + 6x + 6y + 3 = 0$   
(B)  $x^2 + y^2 - 6x - 6y - 9 = 0$   
(C)  $x^2 + y^2 - 6x - 6y + 9 = 0$   
(D)  $x^2 + y^2 - 6x + 6y - 3 = 0$
- (2) If the lines  $2x - 3y = 5$  and  $3x - 4y = 7$  are the diameters of a circle of area 154 sq. units, then find the equation of the circle.  
(A)  $x^2 + y^2 - 2x + 2y = 40$   
(B)  $x^2 + y^2 - 2x - 2y = 47$   
(C)  $x^2 + y^2 - 2x + 2y = 47$   
(D)  $x^2 + y^2 - 2x - 2y = 40$
- (3) Find the equation of the circle which passes through the points  $(2, 3)$  and  $(4, 5)$  and the centre lies on the straight line  $y - 4x + 3 = 0$ .  
(A)  $x^2 + y^2 - 4x - 10y + 25 = 0$   
(B)  $x^2 + y^2 - 4x - 10y - 25 = 0$   
(C)  $x^2 + y^2 - 4x + 10y - 25 = 0$   
(D)  $x^2 + y^2 + 4x - 10y + 25 = 0$
- (4) The equation of the tangent to the circle  $x^2 + y^2 = 4$  which are parallel to  $x + 2y + 3 = 0$  are  
(A)  $x - 2y = 2$                       (B)  $x + 2y = \pm 2\sqrt{3}$   
(C)  $x + 2y = \pm 2\sqrt{5}$               (D)  $x - 2y = \pm 2\sqrt{5}$
- (5) If the lines  $3x - 4y + 4 = 0$  and  $6x - 8y - 7 = 0$  are tangents to a circle, then find the radius of the circle  
(A)  $\frac{3}{4}$               (B)  $\frac{4}{3}$               (C)  $\frac{1}{4}$               (D)  $\frac{7}{4}$

(6) Area of the circle centre at (1, 2) and passing through (4, 6) is

- (A)  $5\pi$                       (B)  $10\pi$   
 (C)  $25\pi$                       (D)  $100\pi$

(7) If a circle passes through the point (0, 0), (a, 0) and (0, b) then find the co-ordinates of its centre.

- (A)  $\left(\frac{-a}{2}, \frac{-b}{2}\right)$       (B)  $\left(\frac{a}{2}, \frac{-b}{2}\right)$   
 (C)  $\left(\frac{-a}{2}, \frac{b}{2}\right)$       (D)  $\left(\frac{a}{2}, \frac{b}{2}\right)$

(8) The equation of a circle with origin as centre and passing through the vertices of an equilateral triangle whose median is of length 3a is

- (A)  $x^2 + y^2 = 9a^2$                       (B)  $x^2 + y^2 = 16a^2$   
 (C)  $x^2 + y^2 = 4a^2$                       (D)  $x^2 + y^2 = a^2$

(9) A pair of tangents are drawn to a unit circle with centre at the origin and these tangents intersect at A enclosing an angle of  $60^\circ$ . The area enclosed by these tangents and the area of the circle is

- (A)  $\frac{2}{\sqrt{3}} - \frac{\pi}{6}$                       (B)  $\sqrt{3} - \frac{\pi}{3}$   
 (C)  $\frac{\pi}{3} - \frac{\sqrt{3}}{6}$                       (D)  $\sqrt{3}\left(1 - \frac{\pi}{6}\right)$

(10) The parametric equations of the circle  $x^2 + y^2 + mx + my = 0$  are

- (A)  $x = \frac{-m}{2} + \frac{m}{\sqrt{2}} \cos \theta$ ,  $y = \frac{-m}{2} + \frac{m}{\sqrt{2}} \sin \theta$   
 (B)  $x = \frac{-m}{2} + \frac{m}{\sqrt{2}} \cos \theta$ ,  $y = \frac{+m}{2} + \frac{m}{\sqrt{2}} \sin \theta$   
 (C)  $x = 0$ ,  $y = 0$   
 (D)  $x = m \cos \theta$ ;  $y = m \sin \theta$

**(II) Answer the following :**

Q. 1 Find the centre and radius of the circle  $x^2 + y^2 - x + 2y - 3 = 0$

Q. 2 Find the centre and radius of the circle  $x = 3 - 4 \sin \theta$ ,  $y = 2 - 4 \cos \theta$

Q. 3 Find the equation of circle passing through the point of intersection of the lines  $x + 3y = 0$  and  $2x - 7y = 0$  whose centre is the point of intersection of lines  $x + y + 1 = 0$  and  $x - 2y + 4 = 0$ .

Q. 4 Find the equation of circle which passes through the origin and cuts off chords of length 4 and 6 on the positive side of x - axis and y axis respectively.

Q. 5 Show that the points (9, 1), (7, 9), (-2, 12) and (6, 10) are concyclic.

Q. 6 The line  $2x - y + 6 = 0$  meets the circle  $x^2 + y^2 + 10x + 9 = 0$  at A and B. Find the equation of circle on AB as diameter.

Q. 7 Show that  $x = -1$  is a tangent to circle  $x^2 + y^2 - 2 = 0$  at (-1, 1).

Q. 8 Find the equation of tangent to the circle  $x^2 + y^2 = 64$  at the point P  $\left(\frac{2\pi}{3}\right)$

Q.9 Find the equation of locus of the point of intersection of perpendicular tangents drawn to the circle  $x = 5 \cos \theta$  and  $y = 5 \sin \theta$ .

Q.10 Find the equation of the circle concentric with  $x^2 + y^2 - 4x + 6y = 1$  and having radius 4 units.

Q.11 Find the lengths of the intercepts made on the co-ordinate axes, by the circle.

(i)  $x^2 + y^2 - 8x + y - 20 = 0$

(ii)  $x^2 + y^2 - 5x + 13y - 14 = 0$

Q.12 Show that the circles touch each other externally. Find their point of contact and the equation of their common tangent.

i)  $x^2 + y^2 - 4x + 10y + 20 = 0$ ,  
 $x^2 + y^2 + 8x - 6y - 24 = 0$ .

ii)  $x^2 + y^2 - 4x - 10y + 19 = 0$ ,  
 $x^2 + y^2 + 2x + 8y - 23 = 0$ .

Q.13 Show that the circles touch each other internally. Find their point of contact and the equation of their common tangent.

i)  $x^2 + y^2 - 4x - 4y - 28 = 0$ ,  
 $x^2 + y^2 - 4x - 12 = 0$ .

ii)  $x^2 + y^2 + 4x - 12y + 4 = 0$ ,  
 $x^2 + y^2 - 2x - 4y + 4 = 0$ .

Q.14 Find the length of the tangent segment drawn from the point (5, 3) to the circle  $x^2 + y^2 + 10x - 6y - 17 = 0$ .

Q.15 Find the value of k, if the length of the tangent segment from the point (8, -3) to the circle.

$x^2 + y^2 - 2x + ky - 23 = 0$  is  $\sqrt{10}$ .

Q.16 Find the equation of tangent to Circle

$x^2 + y^2 - 6x - 4y = 0$ , at the point (6, 4) on it.

Q.17 Find the equation of tangent to Circle

$x^2 + y^2 = 5$ , at the point (1, -2) on it.

Q.18 Find the equation of tangent to Circle

$x = 5 \cos\theta$ ,  $y = 5 \sin\theta$ , at the point  $\theta = \pi/3$  on it.

Q.19 Show that  $2x + y + 6 = 0$  is a tangent to  $x^2 + y^2 + 2x - 2y - 3 = 0$ . Find its point of contact.

Q.20 If the tangent at (3, -4) to the circle  $x^2 + y^2 = 25$  touches the circle  $x^2 + y^2 + 8x - 4y + c = 0$ , find c.

Q.21 Find the equations of the tangents to the circle  $x^2 + y^2 = 16$  with slope -2.

Q.22 Find the equations of the tangents to the circle  $x^2 + y^2 = 4$  which are parallel to  $3x + 2y + 1 = 0$ .

Q.23 Find the equations of the tangents to the circle  $x^2 + y^2 = 36$  which are perpendicular to the line  $5x + y = 2$ .

Q.24 Find the equations of the tangents to the circle  $x^2 + y^2 - 2x + 8y - 23 = 0$  having slope 3.

Q.25 Find the eq<sup>n</sup> of the locus of a point, the tangents from which to the circle  $x^2 + y^2 = 9$  are at right angles.

Q.26 Tangents to the circle  $x^2 + y^2 = a^2$  with inclinations,  $\theta_1$  and  $\theta_2$  intersect in P. Find the locus of such that

i)  $\tan \theta_1 + \tan \theta_2 = 0$     ii)  $\cot \theta_1 + \cot \theta_2 = 5$   
 iii)  $\cot \theta_1 \cdot \cot \theta_2 = c$ .

**Extra Information :**

1)

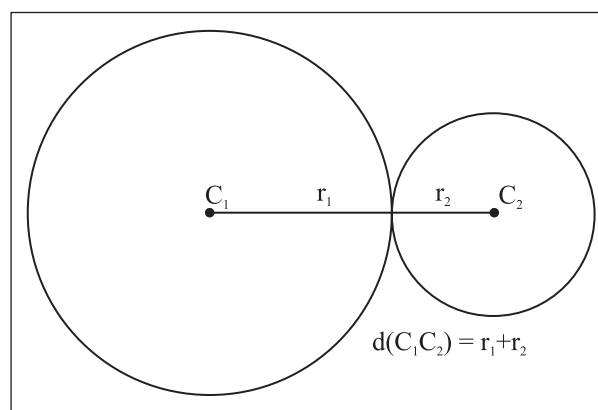

**Fig. 6.10**

Circles touching each other externally.

$d(c_1 c_2) = r_1 + r_2$ .

Exactly three common tangents can be drawn.

2)

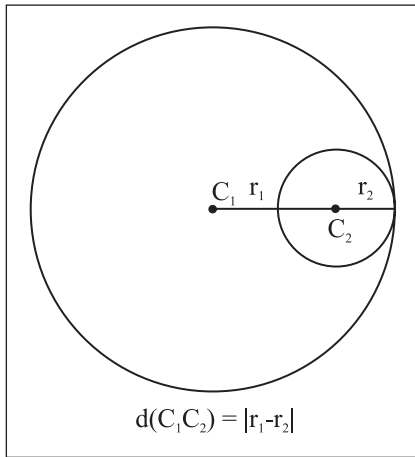

**Fig. 6.11**

Circles touching each other internally.

$$d(c_1, c_2) = |r_1 - r_2|$$

Exactly one common tangent can be drawn.

3)

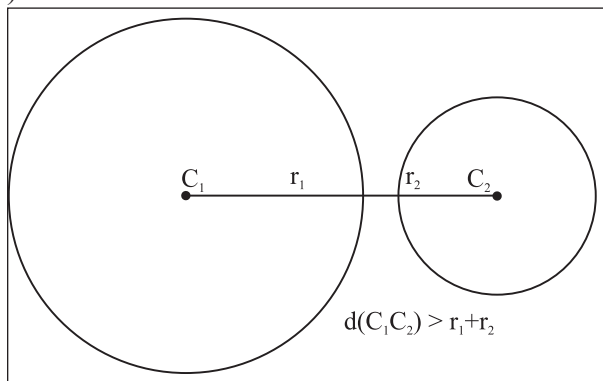

**Fig. 6.12**

Disjoint circles.

$$|r_1 + r_2| < d(c_1, c_2)$$

Exactly four common tangents can be drawn.

4)

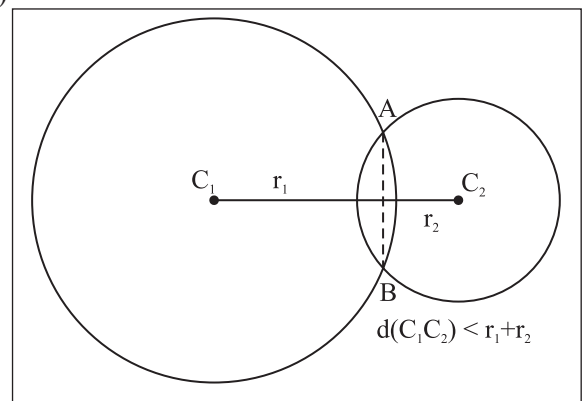

**Fig. 6.13**

Circles intersecting each other.

Line joining the point of intersection is the common chord also called as the radical axis.

(seg AB)

Exactly two common tangent can be drawn.

5)

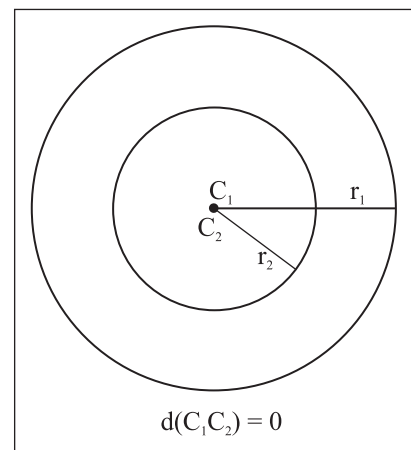

**Fig. 6.14**

Concentric circles

No common tangent can be drawn.



# 7 Conic sections

## Let's Learn

- Conic sections : parabola, ellipse, hyperbola
- Standard equation of conics
- Equation of tangent to the conics
- Condition for tangency

## Let's Recall

- Section formulae : Let A  $(x_1, y_1)$  and B  $(x_2, y_2)$  be two points in a plane. If P and Q divide seg AB in the ratio  $m:n$  internally and externally respectively then

$$P = \left( \frac{mx_2 + nx_1}{m+n}, \frac{my_2 + ny_1}{m+n} \right) \text{ and}$$

$$Q = \left( \frac{mx_2 - nx_1}{m-n}, \frac{my_2 - ny_1}{m-n} \right)$$

### Introduction:

The Greek mathematician Archimedes and Apollonius studied the curves named conic sections. These curves are intersections of a plane with right circular cone. Conic sections have

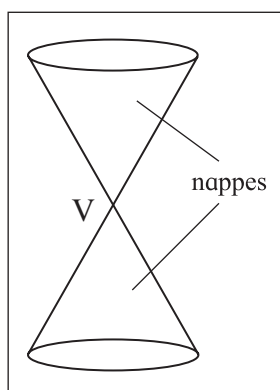

Fig.7.2

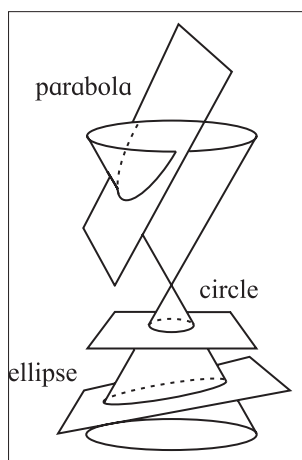

Fig.7.3(a)

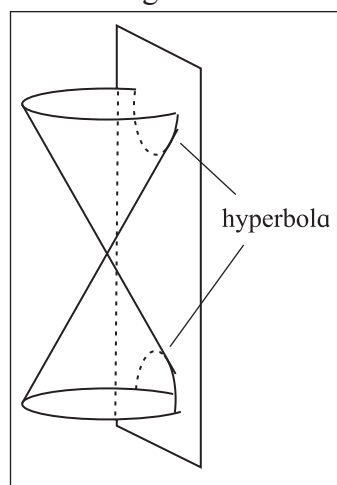

Fig.7.3(b)

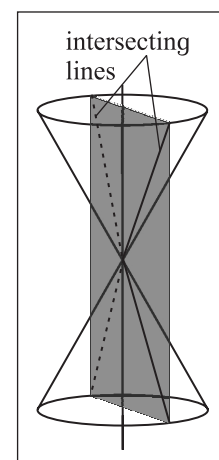

Fig.7.4

a wide range of applications such as planetary motions, in designs of telescopes and antennas, reflection in flash light, automobile headlights, construction of bridges, navigation, projectiles etc.

A straight line, a circle, parabola, ellipse and hyperbola are all conic sections. Of these we have studied circle and straight line.

Earlier we have studied different forms of equations of line, circle, and their properties. In this chapter we shall study some more curves, namely parabola, ellipse and hyperbola which are conic sections.

## Let's Learn

### 7.1.1 Double cone:

Let  $l$  be a fixed line and  $m$  another line intersecting it at a fixed point  $V$  and inclined at an acute angle  $\theta$  (fig 7.1.) Suppose we rotate the line  $m$  around the line  $l$  in such a way that the angle  $\theta$  remains

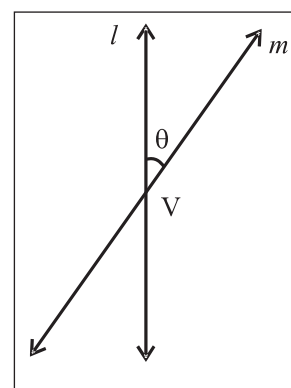

Fig.7.1

constant. Then the surface generated is a double-napped right circular cone.

The point V is called the vertex, the line  $l$  is called axis, and the rotating line  $m$  is called a generator of the cone. The vertex V separates the cone in to two parts called nappes (Fig.7.2).

### 7.1.2. Conic sections :

#### Let's construct

Take a carrot or a cone made of drawing paper and cut it with a plane satisfying the following conditions.

- The plane is perpendicular to the axis and does not contain vertex, the intersection is a circle (studied earlier Fig. 7.3(a)).
- The plane is parallel to one position of the generator but does not pass through the vertex, we get a parabola (Fig. 7.3(a)).
- The plane is oblique to the axis and not parallel to the generator we get an ellipse (Fig. 7.3(a)).
- If a double cone is cut by a plane parallel to axis, we get parts of the curve at two ends called hyperbola (Fig. 7.3(b)).
- A plane containing a generator and tangent to the cone, intersects the cone in that generator. We get pair to straight lines (Fig. 7.4).

### 7.1.3. Definition of a conic section and its equation:

A conic section or conic can be defined as the locus of the point P in a plane such that the ratio of the distance of P from a fixed point to its distance from a fixed line is constant.

The fixed point is called the focus of the conic section, denoted by S. The fixed straight line is called the directrix of conic section, denoted by  $d$ .

If S is the focus, P is any point on the conic section and segment PM is the length of perpendicular from P on the directrix, then by

definition  $\frac{SP}{PM} = \text{constant}$ . (fig. 7.5)

This constant ratio is called the eccentricity of the conic section, denoted by  $e$ .

Hence we write  $\frac{SP}{PM} = e$

or  $SP = e PM$ . This is called Focus - Directrix property of the conic section.

The nature of the conic section depends upon the value of  $e$ .

- If  $e = 1$ , the conic section is called parabola.
- If  $0 < e < 1$ , the conic section is called an ellipse.
- If  $e > 1$ , the conic section is called hyperbola.

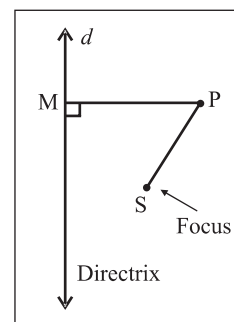

Fig. 7.5

### 7.1.4. Some useful terms of conic sections:

- Axis:** A line about which a conic section is symmetric is called an axis of the conic section.
- Vertex :** The point of intersection of a conic section with its axis of symmetry is called a vertex.
- Focal Distance :** The distance of a point on a conic section from the focus is called the **focal distance of the point**.
- Focal chord :** A chord of a conic section passing through its focus is called a focal chord.
- Latus-Rectum:** A focal chord of a conic section which is perpendicular to the axis of symmetry is called the latus-rectum.
- Centre of a conic :** The point which bisects every chord of the conic passing through it, is called the centre of the conic.
- Double ordinate :** A chord passing through any point on the conic and perpendicular to the axis is called double ordinate.

### 7.1.5. Parabola

**Definition:** A parabola is the locus of the point in plane equidistant from a fixed point and a fixed line in that plane. The fixed point is called the focus and the fixed straight line is called the directrix.

#### Standard equation of the parabola:

Equation of the parabola in the standard form  $y^2 = 4ax$ .

Let S be the focus and  $d$  be the directrix of the parabola.

Let SZ be perpendicular to the directrix. Bisect SZ at the point O. By the definition of parabola the midpoint O is on the parabola. Take O as the origin, line OS as the X - axis and the line through O perpendicular to OS as the Y - axis.

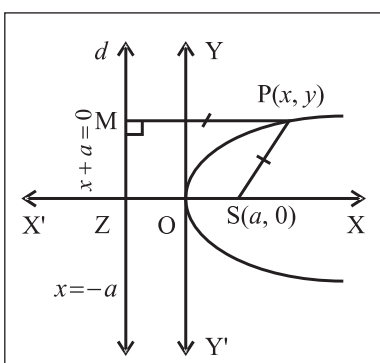

Fig. 7.6

Let  $SZ = 2a, a > 0$ .

Then the coordinates of the focus S are  $(a, 0)$  and the coordinates of Z are  $(-a, 0)$ .

The equation of the directrix  $d$  is

$$x = -a, \text{ i.e. } x + a = 0$$

Let P  $(x, y)$  be any point on the parabola. Draw segment PM perpendicular to the directrix  $d$ .

$$\therefore M = (-a, y)$$

By using distance formula we have

$$SP = \sqrt{(x-a)^2 + (y-0)^2},$$

$$PM = \sqrt{(x+a)^2 + (y-y)^2}$$

By focus - directrix property of the parabola  $SP = PM$

$$\sqrt{(x-a)^2 + (y-0)^2} = \sqrt{(x+a)^2 + (y-y)^2}$$

Squaring both sides  $(x-a)^2 + y^2 = (x+a)^2$

that is  $x^2 - 2ax + a^2 + y^2 = x^2 + 2ax + a^2$

that is  $y^2 = 4ax \ (a > 0)$

This is the equation of parabola in standard form.

#### Activity :

Trace the parabola using focus directrix property.

- 1) find the equation of parabola with focus at  $(2, 0)$  and directrix  $x + 2 = 0$ .
- 2) Find the equation of parabola with focus at  $(-4, 0)$  and directrix  $x = 4$ .

#### 7.1.6. Tracing of the parabola $y^2 = 4ax \ (a > 0)$

- 1) **Symmetry :** Equation of the parabola can be written as  $y = \pm 2\sqrt{ax}$  that is for every value of  $x$ , there are two values of  $y$  which are negatives of each other. Hence parabola is symmetric about X- axis.
- 2) **Region :** For every  $x < 0$ , the value of  $y$  is imaginary therefore entire part of the curve lies to the right of Y-axis.
- 3) **Intersection with the axes:** For  $x = 0$  we have  $y = 0$ , therefore the curve meets the coordinate axes at the origin  $O(0, 0)$
- 4) **Shape of parabola:** As  $x \rightarrow \infty, y \rightarrow \infty$ . Therefore the curve extends to infinity as  $x$  grows large and opens in the right half plane. Shape of the parabola  $y^2 = 4ax \ (a > 0)$  is as shown in figure 7.6.

**7.1.7 Some results**

**1) Focal distance :**

Let  $P(x_1, y_1)$  be any point on the parabola  $y^2 = 4ax$

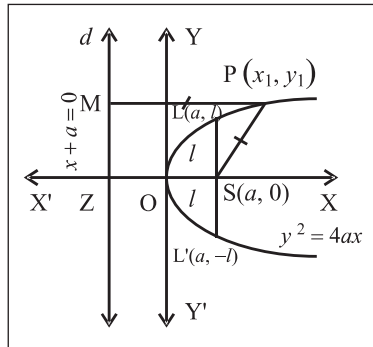

**Fig.7.7**

Let segment PM is perpendicular to the directrix d, then M is  $(-a, y_1)$

$$SP = PM = \sqrt{(x_1 + a)^2 + (y_1 - y_1)^2} = x_1 + a$$

$$\therefore \text{focal distance } SP = x_1 + a$$

$$= a + \text{abscissa of point P.}$$

**2) Length of latus-Rectum:**

In figure 7.7 LSL' is the latus-rectum of the parabola  $y^2 = 4ax$ . By symmetry of the curve

$$LS = L'S = l \text{ (say).}$$

So the coordinates of L are  $(a, l)$

Since L lies on  $y^2 = 4ax$ ,  $l^2 = 4a(a)$

$$l^2 = 4a^2$$

$$l = \pm 2a$$

As L is in the first quadrant,  $l > 0$

$$l = 2a$$

$$\text{Length of latus rectum } LSL' = 2l = 2(2a) = 4a$$

The co-ordinates of ends points of the latus rectum are L  $(a, 2a)$  and L'  $(a, -2a)$

**Activity :**

- 1) Find the length and end points of latus rectum of the parabola  $x^2 = 8y$
- 2) Find the length and end points of latus rectum of the parabola  $5y^2 = 16x$

**7.1.8 Some other standard forms of parabola**

$$y^2 = -4ax$$

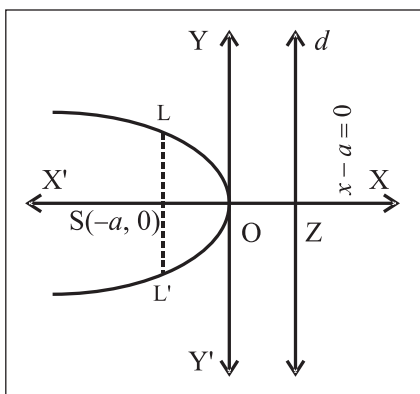

**Fig.7.8**

$$x^2 = 4by$$

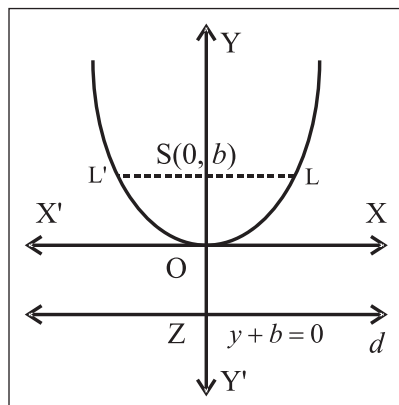

**Fig.7.9**

$$x^2 = -4by$$

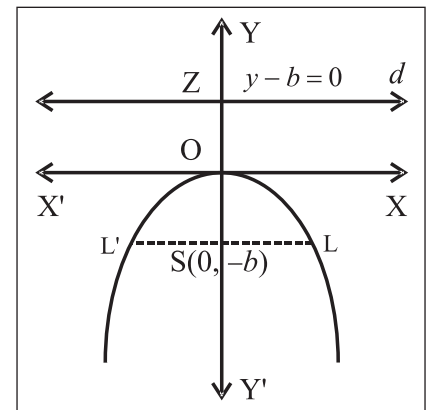

**Fig.7.10**

We summarize the properties of parabola in four standard forms

Equation of the parabola		$y^2 = 4ax$	$x^2 = 4by$
Terms			
1	Focus	(a, 0)	(0, b)
2	Equation of directrix	$x + a = 0$	$y + b = 0$
3	Vertex	0(0,0)	0(0,0)
4	End points of latus rectum	(a, $\pm 2a$ )	( $\pm 2b$ , b)
5	Length of latus rectum	4a	4b
6	Axis of symmetry	X-axis	Y-axis
7	Equation of axis	$y = 0$	$x = 0$
8	Tangent at vertex	Y-axis	X-axis
9	Focal distance of a point P( $x_1, y_1$ )	$ x_1 + a $	$ y_1 + b $

**Parameter :** If the co-ordinates of a point on the curve are expressed as functions of a variable, that variable is called the parameter for the curve.

### 7.1.9 Parametric expressions of standard parabola $y^2 = 4ax$

$x = at^2, y = 2at$  are the expressions which satisfies given equation  $y^2 = 4ax$  for any real value of  $t$  that is  $y^2 = (2at)^2 = 4a^2 t^2 = 4a(at^2) = 4ax$  where  $t$  is a parameter

$P(x_1, y) \equiv (at^2, 2at)$  describes the parabola  $y^2 = 4ax$ , where  $t$  is the parameter.

#### Activity :

- For the parabola  $y^2 = 12x$ , find the parameter for the point a) (3, -6) b) (27, 18)
- Find the parameter for the point (9, -12) of the parabola  $y^2 = 16x$

### 7.1.10 General forms of the equation of a parabola

If the vertex is shifted to the point ( $h, k$ ) we get the following form

$$1) (y - k)^2 = 4a(x - h)$$

This represents a parabola whose axis of symmetry is  $y - k = 0$  which is parallel to the X-axis, vertex is at ( $h, k$ ) and focus is at ( $h + a, k$ ) and directrix is  $x = h - a$ .

It can be reduced to the form  $x = Ay^2 + By + C$ .

OR

$$Y^2 = 4aX, \text{ where } X = x - h, Y = y - k$$

#### Activity :

- Obtain the equation of the parabola with its axis parallel to Y-axis and vertex at ( $h, k$ )
- Find the coordinates of the vertex, focus and equation of the directrix of the parabola  $y^2 = 4x + 4y$

### SOLVED EXAMPLES

**Ex. 1)** Find the coordinates of the focus, equation of the directrix, length of latus rectum and coordinates of end points of latus rectum of each of the following parabolas.

i)  $y^2 = 28x$

ii)  $3x^2 = 8y$

#### Solution:

i)  $y^2 = 28x$

Equation of the parabola is  $y^2 = 28x$

comparing this equation with  $y^2 = 4ax$ , we get  $4a = 28 \therefore a = 7$

Coordinates of the focus are  $S(a, 0) = (7, 0)$

Equation of the directrix is  $x + a = 0$  that is  $x + 7 = 0$

Length of latus rectum  $= 4a = 4 \times 7 = 28$

End points of latus rectum are  $(a, 2a)$  and  $(a, -2a)$ . that is  $(7, 14)$  and  $(7, -14)$

ii)  $3x^2 = 8y$

Equation of the parabola is  $3x^2 = 8y$  that is

$$x^2 = \frac{8}{3}y$$

comparing this equation with  $x^2 = 4by$ , we

$$\text{get } 4b = \frac{8}{3} \therefore b = \frac{2}{3}$$

Co-ordinates of the focus are S  $(0, b) =$

$$\left(0, \frac{2}{3}\right)$$

Equation of the directrix is  $y + b = 0$  that is

$$y + \frac{2}{3} = 0 \text{ that is } 3y + 2 = 0$$

$$\text{Length of latus rectum} = 4b = 4 \times \left(\frac{2}{3}\right) = \frac{8}{3}$$

Coordinates of end points of latus rectum are

$(2b, b)$  and  $(-2b, b)$ . that is  $\left(\frac{4}{3}, \frac{2}{3}\right)$  and

$$\left(-\frac{4}{3}, \frac{2}{3}\right)$$

**Ex. 2)** Find the equation of the parabola with vertex at the origin, axis along Y-axis and passing through the point  $(6, -3)$

**Solution:**

The vertex of the parabola is at the origin, its axis is along Y-axis. Hence equation of the parabola is of the form  $x^2 = 4by$ .

Now the point  $(6, -3)$  lies on this parabola. Hence the coordinates of the points satisfy the equation of the parabola.

$$\therefore (6)^2 = 4b \times (-3)$$

$$\therefore -12b = 36 \therefore b = -3$$

$\therefore$  equation of parabola is  $x^2 = 4(-3)y$

$$x^2 = -12y \text{ that is } x^2 + 12y = 0.$$

**Ex. 3)** Find the equation of the parabola whose directrix is  $x + 3 = 0$

**Solution:**

Here equation of directrix is  $x + a = 0$  that is  $x + 3 = 0$  comparing we get  $a = 3$ .

$\therefore$  Equation of the parabola  $y^2 = 4ax$  that is  $y^2 = 12x$ .

**Ex. 4)** Calculate the focal distance of point P on the parabola  $y^2 = 20x$  whose ordinate is 10

**Solution :** Equation of parabola is  $y^2 = 20x$  comparing this with  $y^2 = 4ax$

we get  $4a = 20 \therefore a = 5$

Here ordinate = y - coordinate = 10

$$\therefore (10)^2 = 20x \therefore 20x = 100$$

$$\therefore x = \frac{100}{20} = 5$$

Now focal distance =  $a + x$

$$= a + \text{abscissa of point}$$

$$= 5 + 5 = 10 \text{ units}$$

**Ex. 5)** Find the equation of the parabola having  $(4, -8)$  as one of extremities of parabola.

**Solution :** Given that, one of the extrimities of the latus rectum of the parabola is  $(4, -8)$  therefore other must be  $(4, 8)$ . End-coordinates of latus - rectum  $(a, \pm 2a) = (4, \pm 8)$ .

$$\therefore a = 4$$

Equation of parabola is  $y^2 = 4ax$

$$y^2 = 4(4)x \therefore y^2 = 16x$$

**Ex. 6)** For the parabola  $3y^2 = 16x$ , find the parameter of the point  $(3, -4)$

**Solution :** Equation of parabola is  $3y^2 = 16x$

$\therefore y^2 = \frac{16}{3}x$  comparing this with  $y^2 = 4ax$  we get

$4a = \frac{16}{3} \therefore a = \frac{4}{3}$  Parametric equations of the

parabola  $y^2 = 4ax$  are  $(at^2, 2at) = \left(\frac{4}{3}t^2, \frac{8}{3}t\right)$

$$\left(\frac{4}{3}t^2, \frac{8}{3}t\right) = (3, -4)$$

Equating second components we get  $\frac{8}{3}t = -4$

$$\therefore t = -4 \times \frac{3}{8} = -\frac{3}{2}$$

$$\therefore \text{Parameter } t = -\frac{3}{2}$$

**Ex. 7)** Find the coordinates of the vertex and focus, the equation of the axis of symmetry, diretrix and tangent at the vertex of the parabola  $x^2 + 4x + 4y + 16 = 0$

**Solution :** Equation of parabola is

$$x^2 + 4x + 4y + 16 = 0$$

$$x^2 + 4x = -4y - 16$$

$$x^2 + 4x + 4 = -4y - 12$$

$$(x+2)^2 = -4(y+3)$$

Comparing this equation with  $X^2 = -4bY$

We get  $X = x + 2$ ,  $Y = y + 3$  and  $4b = -4$

$$\therefore b = -1$$

Coordinates of the vertex are  $X = 0$  and  $Y = 0$  that is  $x + 2 = 0$  and  $y + 3 = 0$

$$\therefore x = -2 \text{ and } y = -3$$

$$\therefore \text{Vertex} = (x, y) = (-2, -3)$$

Coordinates of focus are given by  $X = 0$  and  $Y = +b$

that is  $x + 2 = 0$  and  $y + 3 = -1$

$$\therefore x = -2 \text{ and } y = -4$$

$$\therefore \text{Focus} = (-2, -4)$$

Equation of axis is  $X = 0$  that is  $x + 2 = 0$

Equation of diretrix is  $Y + b = 0$  that is  $y + 3 - 1 = 0$  that is  $y + 2 = 0$

Equation of tangent at vertex is  $Y = 0$  that is  $y + 3 = 0$

### 7.1.11 Tangent :

A straight line which intersects the parabola in coincident point is called a tangent of the parabola

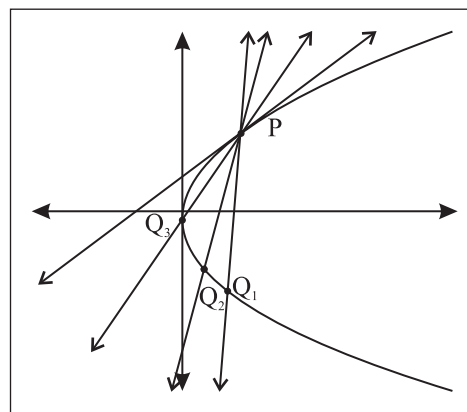

**Fig. 7.11**

Point Q moves along the curve to the point P. The limiting position of secant PQ is the tangent at P.

A tangent to the curve is the limiting position of a secant intersecting the curve in two points and moving so that those points of intersection come closer and finally coincide.

### Tangent at a point on a parabola.

Let us find the equation of tangent to the parabola at a point on it in cartesian form and in parametrics form.

We find the equation of tangent to the parabola  $y^2 = 4ax$  at the point  $P(x_1, y_1)$  on it. Hence, obtain the equation of tangent at  $P(t)$ .

Equation of the tangent to the curve  $y = f(x)$  at point  $(x_1, y_1)$  on it is,

$$y - y_1 = [f'(x)]_{(x_1, y_1)} (x - x_1) [f'(x)]_{(x_1, y_1)}$$

We need to know the slope of the tangent at  $P(x_1, y_1)$ . From the theory of derivative of a function,

the slope of the tangent is  $\frac{dy}{dx}$  at  $(x_1, y_1)$

and here  $\left. \frac{dy}{dx} \right|_{(x_1, y_1)} = \frac{2a}{y_1}$

The equation of parabola is  $y^2 = 4ax$ , differentiate both sides with respect to  $x$

We get  $2y \frac{dy}{dx} = 4a$  (1)

$\therefore \frac{dy}{dx} = \frac{2a}{y}$

$\therefore \left. \frac{dy}{dx} \right|_{(x_1, y_1)} = \frac{2a}{y_1}$  = slope of the tangent at  $P(x_1, y_1)$

$\therefore$  Equation of the tangent at  $P(x_1, y_1)$  is  $y - y_1 = \frac{2a}{y_1} (x - x_1)$

$yy_1 - y_1^2 = 2a(x - x_1)$

$yy_1 - y_1^2 = 2ax - 2ax_1$

Now  $P(x_1, y_1)$  lies on the parabola  $\therefore y_1^2 = 4ax_1$

$\therefore yy_1 - 4ax_1 = 2ax - 2ax_1$

$\therefore yy_1 = 2ax + 2ax_1$

$\therefore yy_1 = 2a(x + x_1)$  .....(I)

This is the equation of the tangent at  $P(x_1, y_1)$  on it

Now,  $t_1$  is the parameter of point P

$\therefore P(x_1, y_1) = (at_1^2, 2at_1)$  that is  $x_1 = at_1^2, y_1 = 2at_1$

Substituting these values in equation (1), we get

$y(2at_1) = 2a(x + at_1^2)$

that is  $y t_1 = x + a t_1^2$

This is the required equation of the tangent at P(t).

Thus, the equation of tangent to the parabola  $y^2 = 4ax$  at point  $(x, y)$  on it is  $yy_1 = 2a(x + x_1)$  or  $yt_1 = x + at_1^2$  where  $t_1$  is the parameter.

**7.1.12 Condition of tangency**

To find the condition that the line  $y = mx + c$  is tangent to the parabola  $y^2 = 4ax$ . Also to find the point of contact.

Equation of the line is  $y = mx + c$

$\therefore mx - y + c = 0$  .....(I)

equation of the tangent at  $P(x_1, y_1)$  to the parabola

$y^2 = 4ax$  is  $yy_1 = 2a(x + x_1)$

$\therefore 2ax - y_1y + 2ax_1 = 0$  .....(II)

If the line given by equation (I) is a tangent to the parabola at  $(x_1, y_1)$ . Equation (I) and equation (II) represents the same line.

Comparing the co-efficients of like terms in equations (I) and (II)

we get  $\frac{2a}{m} = \frac{-y_1}{-1} = \frac{2ax_1}{c}$

$\therefore x_1 = \frac{c}{m}$  and  $y_1 = \frac{2a}{m}$

But the point  $P(x_1, y_1)$  lies on the parabola

$\therefore y_1^2 = 4ax_1$

$\therefore \left(\frac{2a}{m}\right)^2 = 4a\left(\frac{c}{m}\right)$

$\frac{4a^2}{m^2} = 4a\left(\frac{c}{m}\right)$

$\therefore c = \frac{a}{m}$

this is the required condition of tangency.

Thus the line  $y = mx + c$  is tangent the parabola  $y^2 = 4ax$  if  $c = \frac{a}{m}$  and the point of contact is  $\left(\frac{c}{m}, \frac{2a}{m}\right)$  i.e.  $\left(\frac{a}{m^2}, \frac{2a}{m}\right)$

The equation of tangent in terms of slope is  $y = mx + \frac{a}{m}$

**7.1.13 Tangents from a point to a parabola**

In general, two tangents can be drawn to a parabola  $y^2 = 4ax$  from any point in its plane.

Let P  $(x_1, y_1)$  be any point in the plane of parabola.

Equation of tangent to the parabola  $y^2 = 4ax$  is

$y = mx + \frac{a}{m}$

Since the tangent passes through P  $(x_1, y_1)$ , we

have  $y_1 = mx_1 + \frac{a}{m}$

$\therefore my_1 = m^2x_1 + a$

$m^2x_1 - my_1 + a = 0$  .....(1)

$x_1m^2 - y_1m + a = 0$

This is quadratic equation in  $m$  and in general it has two roots say,  $m_1$  and  $m_2$  which are the slopes of two tangents.

Thus, in general, two tangents can be drawn to a parabola from a given point in its plane.

If the tangent drawn from  $P$  are mutually perpendicular we have

$$m_1 m_2 = -1$$

From equation (1)  $m_1 m_2 = \frac{a}{x_1}$  (product of roots)

$$\therefore \frac{a}{x_1} = -1$$

$$\therefore x_1 = -a$$

which is the equation of directrix.

Thus, the locus of the point, the tangents from which to the parabola are perpendicular to each other is the directrix of the parabola.

### SOLVED EXAMPLES

**Ex. 1)** Find the equation of tangent to the parabola  $y^2 = 9x$  at  $(1, -3)$ .

**Solution :**

Equation of the parabola is  $y^2 = 9x$ ;

comparing it with  $y^2 = 4ax$

$$4a = 9 \Rightarrow a = \frac{9}{4}$$

Tangent is drawn to the parabola at  $(1, -3) = (x_1, y_1)$

Equation of tangent to the parabola  $y^2 = 4ax$  at  $(x_1, y_1)$  is  $yy_1 = 2a(x + x_1)$

$\therefore$  Equation of tangent to the parabola

$$y^2 = 4x \text{ at } (1, -3) \text{ is } y(-3) = 2\left(\frac{9}{4}\right)(x + 1)$$

$$\text{i.e. } -3y = \left(\frac{9}{2}\right)(x + 1)$$

$$\text{i.e. } -6y = 9x + 9$$

$$\text{i.e. } 3x + 2y + 3 = 0$$

**Ex. 2)** Find the equation to tangent to the parabola  $y^2 = 12x$  from the point  $(2, 5)$ .

**Solution :**

Equation of the parabola is  $y^2 = 12x$

comparing it with  $y^2 = 4ax \Rightarrow 4a = 12$

$$\therefore a = 3$$

Tangents are drawn to the parabola from the point  $(2, 5)$ .

We know, equation of tangent to the parabola  $y^2 = 4ax$  having slopes  $m$  is  $y = mx + \frac{a}{m}$ .

$$(5) = m(2) + \frac{(3)}{m}$$

$$5m = 2m^2 + 3$$

$$2m^2 - 5m + 3 = 0$$

$$2m^2 - 2m - 3m + 3 = 0$$

$$(2m - 3)(m - 1) = 0$$

$$m = \frac{3}{2} \quad \text{or} \quad m = 1$$

These are the slopes of tangents.

Therefore the equations of tangents by slope - point form are

$$(y - 5) = \frac{3}{2}(x - 2) \quad \text{and} \quad (y - 5) = 1(x - 2)$$

$$\therefore 2y - 10 = 3x - 6 \quad \text{and} \quad y - 5 = x - 2$$

$$\therefore 3x - 2y + 4 = 0 \quad \text{and} \quad x - y + 3 = 0$$

**Ex. 3)** Show that the tangents drawn from the point  $(-4, -9)$  to the parabola  $y^2 = 16x$  are perpendicular to each other.

**Solution :**

Equation of the parabola is  $y^2 = 16x$ .

comparing it with  $y^2 = 4ax \Rightarrow 4a = 16$

$$\therefore a = 4$$

Tangents are drawn to the parabola from point  $(-4, -9)$ .

Equation of tangent to the parabola  $y^2 = 4ax$

having slope  $m$  is  $y = mx + \frac{a}{m}$

$$\therefore (-9) = m(-4) + \frac{4}{m}$$

$$\therefore -9m = -4m^2 + 4$$

$$\therefore 4m^2 - 9m + 4 = 0$$

$m_1$  and  $m_2$  be the slopes (roots)

$$(m_1 \cdot m_2) = + \frac{\text{constant}}{\text{co-efficient of } m^2}$$

$$m_1 \cdot m_2 = -\frac{4}{4} \quad \therefore m_1 \cdot m_2 = -1$$

hence tangents are perpendicular to each other.

### Activity :

- 1) Find the equation of tangent to the parabola  $y^2 = 9x$  at the point (4,-6)
- 2) Find the equation of tangent to the parabola  $y^2 = 24x$  having slope  $3/2$
- 3) Show that the line  $y = x + 2$  touches the parabola  $y^2 = 8x$ . Find the coordinates of point of contact.

### EXERCISE 7.1

- 1) Find co-ordinate of focus, equation of directrix, length of latus rectum and the co ordinate of end points of latus rectum of the parabola i)  $5y^2 = 24x$  ii)  $y^2 = -20x$  iii)  $3x^2 = 8y$  iv)  $x^2 = -8y$  v)  $3y^2 = -16x$
- 2) Find the equation of the parabola with vertex at the origin, axis along Y-axis and passing through the point (-10,-5)
- 3) Find the equation of the parabola with vertex at the origin, axis along X-axis and passing through the point (3,4)
- 4) Find the equation of the parabola whose vertex is O (0,0) and focus at(-7,0).
- 5) Find the equation of the parabola with vertex at the origin, axis along X-axis and passing through the point i) (1,-6) ii) (2,3)
- 6) For the parabola  $3y^2 = 16x$ , find the parameter of the point a) (3,-4) b) (27,-12)
- 7) Find the focal distance of a point on the parabola  $y^2 = 16x$  whose ordinate is 2 times the abscissa.
- 8) Find coordinate of the point on the parabola. Also find focal distance. i)  $y^2 = 12x$  whose parameter is  $1/3$  ii)  $2y^2 = 7x$  whose parameter is  $-2$
- 9) For the parabola  $y^2 = 4x$ , find the coordinate of the point whose focal distance is 17.
- 10) Find length of latus rectum of the parabola  $y^2 = 4ax$  passing through the point (2,-6).
- 11) Find the area of the triangle formed by the line joining the vertex of the parabola  $x^2 = 12y$  to the end points of latus rectum.
- 12) If a parabolic reflector is 20cm in diameter and 5 cm deep, find its focus.
- 13) Find coordinate of focus, vertex and equation of directrix and the axis of the parabola  $y = x^2 - 2x + 3$
- 14) Find the equation of tangent to the parabola i)  $y^2 = 12x$  from the point (2,5) ii)  $y^2 = 36x$  from the point (2,9)
- 15) If the tangent drawn from the point (-6,9) to the parabola  $y^2 = kx$  are perpendicular to each other, find k.
- 16) Two tangents to the parabola  $y^2 = 8x$  meet the tangents at the vertex in the point P and Q. If  $PQ = 4$ , prove that the equation of the locus of the point of intersection of two tangent is  $y^2 = 8(x + 2)$ .
- 17) Find the equation of common tangent to the parabola  $y^2 = 4x$  and  $x^2 = 32y$ .
- 18) Find the equation of the locus of a point, the tangents from which to the parabola  $y^2 = 18x$  are such that some of their slopes is -3
- 19) The tower of a bridge, hung in the form of a parabola have their tops 30 meters above the road way and are 200 meters apart. If the cable is 5meters above the road way at the centre of the bridge, find the length of the vertical supporting cable from the centre.
- 20) A circle whose centre is (4,-1) passes through the focus of the parabola  $x^2 + 16y = 0$ .  
Show that the circle touches the diretrixs of the parabola.

## 7.2 Ellipse



### Let's Study

- Standard equation of the ellipse.
- Equation of tangent to the ellipse.
- Condition for tangency.
- Auxilary circle and director circle of the ellipse

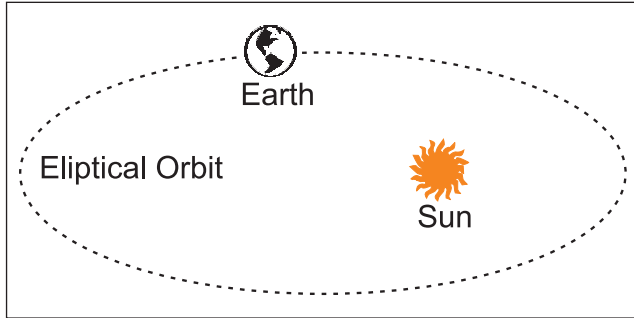

Fig. 7.12

The ellipse is the intersection of double napped cone with an oblique plane.

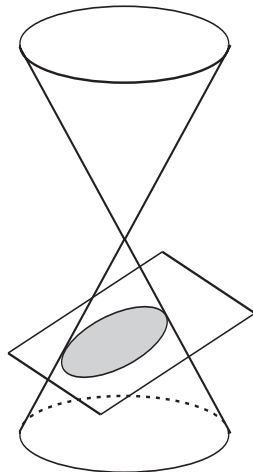

Fig. 7.14

An ellipse is the locus of a point in a plane which moves so that its distance from a fixed point bears a constant ratio  $e$  ( $0 < e < 1$ ) to its distance from a fixed line. The fixed point is called the focus  $S$  and the fixed line is called the directrix  $d$ .

If  $S$  is a fixed point is called focus and directrix  $d$  is a fixed line not containing the focus then by definition  $\frac{PS}{PM} = e$  and  $PS = e PM$ , where

$PM$  is the perpendicular on the directrix and  $e$  is the real number with  $0 < e < 1$  called eccentricity of the ellipse.

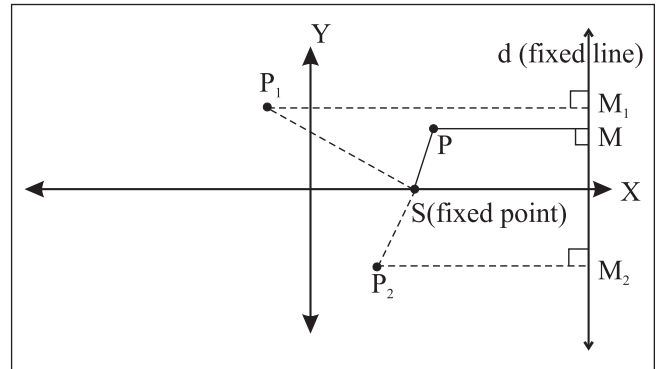
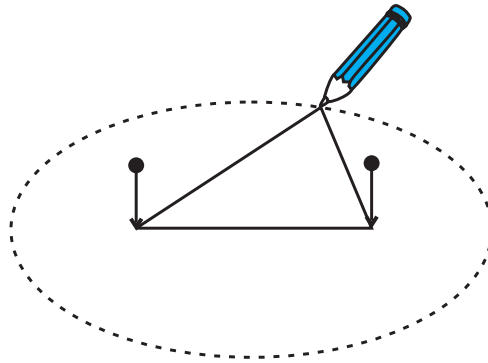

Fig. 7.13

### 7.2.1 Standard equation of ellipse

Let's derive the standard equation of the ellipse

$$\frac{x^2}{a^2} + \frac{y^2}{b^2} = 1, a > b$$



How to draw an ellipse

Fig. 7.15

Let  $S$  be the focus,  $d$  be the directrix and  $e$  be the eccentricity of an ellipse.

Draw  $SZ$  perpendicular to directrix. let  $A$  and  $A'$  divide the segment  $SZ$  internally as well as externally in the ratio  $e : 1$ .

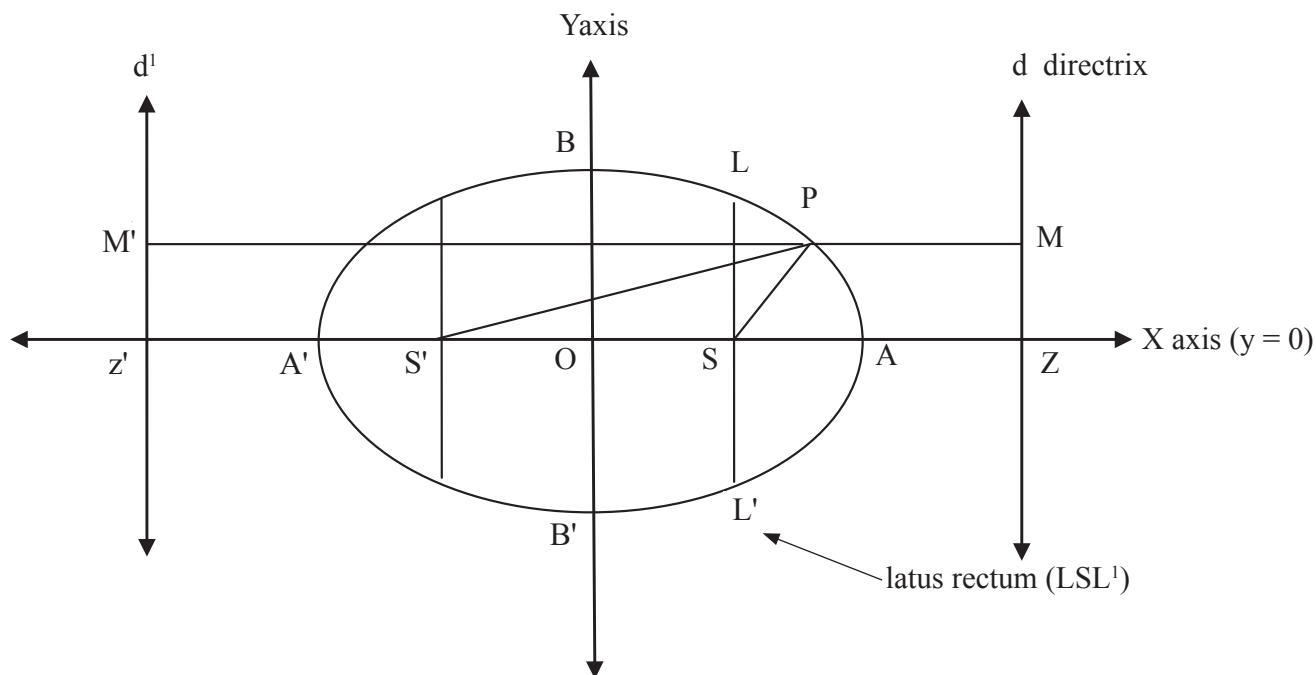

Fig. 7.16

let  $AA' = 2a$ , midpoint  $O$  of segment  $AA'$  be the origin. Then  $O \equiv (0,0)$ ,  $A \equiv (a, 0)$  and  $A' \equiv (-a, 0)$

By definition of ellipse  $A$  and  $A'$  lie on ellipse.

$$\frac{SA}{AZ} = \frac{e}{1} \quad \frac{SA'}{A'Z} = \frac{-e}{1}$$

Let  $P(x, y)$  be any point on the ellipse.

Since  $P$  is on the ellipse  $SP = e PM \dots (1)$

therefore  $SA = e AZ$ .

Let  $Z \equiv (k,0)$  and  $S \equiv (h,0)$

By section formula

$$a = \frac{ek+1h}{e+1} \quad \text{also } -a = \frac{ek-1h}{e-1}$$

$$ae + a = ek + h \quad \dots (2)$$

$$-ae + a = ek - h \quad \dots (3)$$

Solving these equations, we get

$$k = a/e \text{ and } h = ae$$

Focus  $S \equiv (ae, 0)$  and  $Z \equiv (a/e, 0)$

Equation of the directrix is  $x = \frac{a}{e}$

$$\text{That is } x - \frac{a}{e} = 0.$$

$SP =$  focal distance

$$= \sqrt{(x-ae)^2 + (y-0)^2} \dots (4)$$

$PM =$  distance of point  $P$  from directrix

$$= \left| \frac{x - \frac{a}{e}}{\sqrt{1^2 + 0^2}} \right| = \left| x - \frac{a}{e} \right| \dots (5)$$

From (1), (4) and (5)

$$\sqrt{(x-ae)^2 + (y-0)^2} = e \left| x - \frac{a}{e} \right|$$

$$\sqrt{(x-ae)^2 + (y-0)^2} = |ex - a|$$

Squaring both sides

$$(x-ae)^2 + (y-0)^2 = e^2x^2 - 2aex + a^2$$

$$x^2 - 2aex + a^2e^2 + y^2 = e^2x^2 - 2aex + a^2$$

$$x^2 + a^2e^2 + y^2 = e^2x^2 + a^2$$

$$(1 - e^2)x^2 + y^2 = a^2(1 - e^2)$$

Since  $(1 - e^2) > 0$ , Dividing both sides by  $a^2(1 - e^2)$

$$\frac{x^2}{a^2} + \frac{y^2}{a^2(1 - e^2)} = 1$$

$$\frac{x^2}{a^2} + \frac{y^2}{b^2} = 1 \text{ where } b^2 = a^2(1 - e^2) \text{ and } a > b$$

This is the standard equation of ellipse .

We also get for a point P(x,y) on the locus  $PS' = e PM'$  . . . (6) where PM' is the perpendicular on

directrix  $x = -\frac{a}{e}$ , from point P.

S'P = focal distance

$$= \sqrt{(x + ae)^2 + (y - 0)^2} \dots\dots(7)$$

PM' = distance of point P from directrix

$$= \left| \frac{x + \frac{a}{e}}{\sqrt{1^2 + 0^2}} \right| = \left| x + \frac{a}{e} \right| \dots\dots(8)$$

From (6), (7) and (8)

$$\sqrt{(x + ae)^2 + (y - 0)^2} = e \left| x + \frac{a}{e} \right|$$

$$\sqrt{(x + ae)^2 + (y - 0)^2} = |ex + a|$$

Squaring both sides

$$(x + ae)^2 + (y - 0)^2 = e^2x^2 + 2aex + a^2$$

$$x^2 + 2aex + a^2e^2 + y^2 = e^2x^2 + 2aex + a^2$$

$$x^2 + a^2e^2 + y^2 = e^2x^2 + a^2$$

$$(1 - e^2)x^2 + y^2 = a^2(1 - e^2)$$

Since  $(1 - e^2) > 0$ ,

Dividing both sides by  $a^2(1 - e^2)$

$$\frac{x^2}{a^2} + \frac{y^2}{a^2(1 - e^2)} = 1$$

$$\frac{x^2}{a^2} + \frac{y^2}{b^2} = 1 \text{ where } b^2 = a^2(1 - e^2) \text{ and } a > b$$

Thus for the ellipse  $(ae, 0)$  and  $(-ae, 0)$  are two foci and  $x = \frac{a}{e}$  and  $x = -\frac{a}{e}$  are corresponding two directrices.

∴ Standard equation of Ellipse is  $\frac{x^2}{a^2} + \frac{y^2}{b^2} = 1$

**Note:**

Equation of the ellipse  $\frac{x^2}{a^2} + \frac{y^2}{b^2} = 1$  ( $a > b$ )

- i) The ellipse Intersects x-axis at A(a, 0), A'(-a, 0) and y-axis at B(0, b), B'(0, -b), these are the vertices of the ellipse.
- ii) The line segment through the foci of the ellipse is called the major axis and the line segment through centre and perpendicular to major axis is the minor axis. The major axis and minor axis together are called principal axis of the ellipse. In the standard form X axis is the major axis and Y axis is the minor axis.
- iii) The segment AA' of length 2a is called the major axis and the segment BB' of length 2b is called the minor axis. Ellipse is symmetric about both the axes.
- iv) The origin O bisects every chord through it therefore origin O is called the centre of the ellipse.
- v) latus rectum is the chord through focus which is perpendicular to major axis. It is bisected at the focus. There are two latera recta as there are two foci.

### 7.2.2 Some Results :

#### 1) Distance between directrices

d (dd') is the same that of distance ZZ' ie. d (ZZ')

Z (a/e, 0) and Z' (-a/e, 0)

$$\begin{aligned} \Rightarrow d (dd') &= d (zz') = \left| \frac{a}{e} - \left( -\frac{a}{e} \right) \right| \\ &= 2 \frac{a}{e} \end{aligned}$$

**2) End co-ordinates of latera recta**

Let LSL' be the latus rectum of the ellipse.

$$\frac{x^2}{a^2} + \frac{y^2}{b^2} = 1 \quad a > b \quad (\text{refer fig. 7.16})$$

(SL and SL' are the semi latus rectum)

Let : L  $\equiv$  (ae, l)

$$\frac{(ae)^2}{a^2} + \frac{(l^2)}{b^2} = 1$$

$$e^2 + \frac{l^2}{b^2} = 1$$

$$\frac{l^2}{b^2} = 1 - e^2$$

$$l^2 = b^2 (1 - e^2)$$

$$l^2 = b^2 \left( \frac{b^2}{a^2} \right) \quad [\because b^2 = a^2 (1 - e^2)]$$

$$l^2 = \frac{b^4}{a^2}$$

$$l = \pm \frac{b^2}{a}$$

$$L = \left( ae, \frac{b^2}{a} \right) \text{ and } L' = \left( ae, -\frac{b^2}{a} \right)$$

These are the co-ordinates of end points of latus rectum.

**3) Length of latus rectum**

$$l(\text{LSL}') = l(\text{SL}) + l(\text{SL}') = \frac{b^2}{a} + \frac{b^2}{a} = \frac{2b^2}{a}$$

4) SP and S'P are the focal distances of the point P on the ellipse. (ref. Fig.7.17)

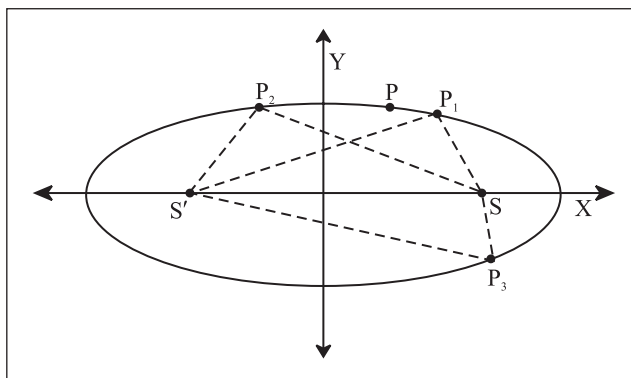

**Fig. 7.17**

$$SP = e PM \text{ and } S'P = e PM'$$

Sum of focal distances of point P

$$SP + S'P = e PM + e PM'$$

$$= e (PM + PM')$$

$$= e (MM')$$

$$= e (\text{distance between the directrix})$$

$$= e \left( 2 \times \frac{a}{e} \right) = 2a$$

$$SP + S'P = 2a = \text{constant}$$

$$= \text{length of major axis.}$$

Sum of focal distances of point on the ellipse is the length of major axis which is a constant.

Using this property one can define and draw an ellipse. If  $S_1$  and  $S_2$  are two fixed points and a point P moves in the plane such that  $PS_1 + PS_2$  is equal to constant K, where  $K > d(S_1, S_2)$ , then the locus of P is an ellipse with  $S_1$  and  $S_2$  as foci. Here in the standard form  $K = 2a$ .

5) A circle drawn with the major axis AA' as a diameter is called an auxiliary circle of the ellipse.

**6) Parametric form of an ellipse**

P(x, y) be any point on the ellipse. Let Q

be a point on the auxiliary circle such that QPN  $\perp$  to the major axis.

Let  $m \angle XOQ = \theta \therefore Q = (a \cos \theta, a \sin \theta)$

Let  $P(x, y) \equiv (a \cos \theta, y)$ .

$$\frac{(a \cos \theta)^2}{a^2} + \frac{y^2}{b^2} = 1$$

$$\cos^2 \theta + \frac{y^2}{b^2} = 1$$

$$y^2 = b^2 (1 - \cos^2 \theta)$$

$$y^2 = b^2 \sin^2 \theta$$

$$y = \pm b \sin \theta$$

$$P(x, y) \equiv (a \cos \theta, b \sin \theta) \equiv P(\theta)$$

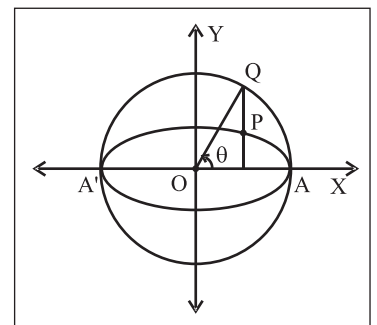

**Fig. 7.18**

Thus  $x = a \cos\theta$  and  $y = b \sin\theta$  is the parametric form of the ellipse  $\frac{x^2}{a^2} + \frac{y^2}{b^2} = 1$  ( $a > b$ ) where  $\theta$  is the parameter which is called as an eccentric angle of the point P.

**To find the eccentric angle of a point P(x,y) on the ellipse in terms of x and y.**

If  $\theta$  is the eccentric angle of P, we know that

$$x = a \cos\theta, y = b \sin\theta \text{ then } \tan\theta = \frac{\frac{y}{b}}{\frac{x}{a}} = \frac{ay}{bx}, \text{ that}$$

$$\text{is } \theta = \tan^{-1} \frac{ay}{bx}$$

note that  $\theta$  is not the angle made by OP with X axis.

7)  $\frac{x^2}{a^2} + \frac{y^2}{b^2} = 1$  ( $b > a$ ) is other standard form of the ellipse.

It is called vertical ellipse. (Ref. figure 7.22)

1	Standard equation	$\frac{x^2}{a^2} + \frac{y^2}{b^2} = 1, a > b$	$\frac{x^2}{a^2} + \frac{y^2}{b^2} = 1, b > a$
2	Centre	0(0,0)	0(0,0)
3	Axes of symmetry	Both x axis and y axis	Both x axis and y axis
4	Vertices	A(a,0) A'(-a,0) B(0,b) B'(0,-b)	A(a,0) A'(-a,0) B(0,b) B'(0,-b)
5	Major axis and minor axis	X axis and Y axis	X axis and Y axis
6	Length of major axis	2a	2b
7	Length of minor axis	2b	2a
8	Relation between a b and c	$b^2 = a^2 (1 - e^2)$	$a^2 = b^2 (1 - e^2)$
9	Foci	S(ae, 0) S(-ae,0)	S(0,be) S(0, -be)
10	Distance between foci	2 ae	2 be
11	Equation of directrix	$x = \frac{a}{e}$ , and $x = -\frac{a}{e}$	$y = \frac{b}{e}$ and $y = -\frac{b}{e}$ .
12	Distance between the directrix	$\frac{2a}{e}$	$\frac{2a}{e}$ .
13	End points of latus rectum	$L = \left( ae, \frac{b^2}{a} \right)$ and $L' = \left( ae, -\frac{b^2}{a} \right)$	$L \left( \frac{a^2}{b}, be \right)$ $L' \left( -\frac{a^2}{b}, be \right)$
14	Length of latus rectum	$\frac{2b^2}{a}$	$\frac{2a^2}{b}$
15	Parametric form	$x = a \cos\theta$ and $y = b \sin\theta$	$x = a \cos\theta$ and $y = b \sin\theta$
16	Equation of tangent at vertex	$x = a, x = -a$ and $y = b, y = -b$	$x = a, x = -a$ and $y = b, y = -b$
17	Sum of Focal distance of a point P(x <sub>1</sub> , y <sub>1</sub> ) is the length of it's	2 a major axis	2 b major axis

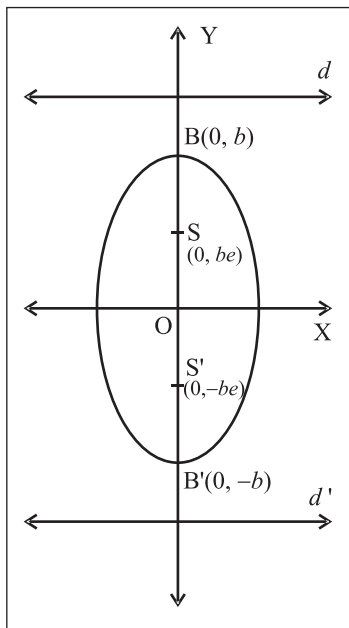

Fig. 7.19

**SOLVED EXAMPLES**

**Ex. 1)** Find the coordinates of the foci, the vertices, the length of major axis, the eccentricity and the length of the latus rectum of the ellipse

- i)  $\frac{x^2}{16} + \frac{y^2}{9} = 1$
- ii)  $4x^2 + 3y^2 = 1$
- iii)  $3x^2 + 4y^2 = 1$
- iv)  $4x^2 + 9y^2 - 16x + 54y + 61 = 0$

**Solution :**

i) Given equation of an ellipse is  $\frac{x^2}{16} + \frac{y^2}{9} = 1$

Comparing with standard equation  $\frac{x^2}{a^2} + \frac{y^2}{b^2} = 1$

$a^2 = 16 ; b^2 = 9$

$a = 4 ; b = 3 (a > b)$

X-axis ( $y = 0$ ) is the major axis and y-axis ( $x = 0$ ) the minor axis.

Centre O (0, 0)

Vertices  $A(\pm a, 0) \equiv (\pm 4, 0)$  ,  $B(0, \pm b) \equiv (0, \pm 3)$

Length of major axis ( $2a$ ) =  $2(4) = 8$

Length of minor axis ( $2b$ ) =  $2(3) = 6$

By relation between a, b and e.

$b^2 = a^2 (1 - e^2)$

$9 = 16 (1 - e^2)$

$\frac{9}{16} = 1 - e^2$

$e^2 = 1 - \frac{9}{16}$

$e^2 = \frac{7}{16}$  that is  $e = \pm \frac{\sqrt{7}}{4}$

but  $0 < e < 1$  therefore  $e = \frac{\sqrt{7}}{4}$

Foci  $S(ae, 0) \equiv \left(4 \cdot \frac{\sqrt{7}}{4}, 0\right) = (\sqrt{7}, 0)$

$S'(-ae, 0) = \left(-4 \cdot \frac{\sqrt{7}}{4}, 0\right) = (-\sqrt{7}, 0)$

Distance between foci =  $2ae = 2\sqrt{7}$ ,

Equation of directrix  $x = \pm \frac{a}{e}$

$x = \pm \frac{4}{\frac{\sqrt{7}}{4}}$  that is  $x = \pm \frac{16}{\sqrt{7}}$

distance between directrix =  $2 \frac{a}{e} = 2 \left(\frac{16}{\sqrt{7}}\right) = \frac{32}{\sqrt{7}}$

End coordinates of latus rectum

$L\left(ae, \frac{b^2}{a}\right) = \left(\sqrt{7}, \frac{9}{4}\right)$

$L'\left(ae, -\frac{b^2}{a}\right) = \left(\sqrt{7}, -\frac{9}{4}\right)$

Length of latus rectum =  $\frac{2b^2}{a} = 2 \left(\frac{9}{4}\right) = \frac{9}{2}$

Parametric form  $x = a \cos \theta, y = b \sin \theta$

That is  $x = 4 \cos \theta, y = 3 \sin \theta$

ii)  $3x^2 + 4y^2 = 1$

$$= \frac{x^2}{\frac{1}{3}} + \frac{y^2}{\frac{1}{4}} = 1$$

Comparing with  $\frac{x^2}{a^2} + \frac{y^2}{b^2} = 1$

$$a^2 = \frac{1}{3}, b^2 = \frac{1}{4}$$

$$a = \frac{1}{\sqrt{3}}, b = \frac{1}{2} \quad (a > b)$$

∴ Major axis is

By the relation between  $a, b$  &  $e$

$$\text{input} = \text{input} (1 - e^2)$$

$$(1 - e^2) = \frac{\text{input}}{\text{input}}$$

$$\therefore e^2 = \text{input} \Rightarrow e = \frac{1}{2} \quad \because 0 < e < 1$$

centre is at  $O(0, 0)$

vertices  $(\pm a, 0) = (\pm \frac{1}{\sqrt{3}}, 0)$  and

$$(0, \pm b) = (0, \pm \frac{1}{2})$$

$$\text{foci } (\pm ae, 0) = (\pm \frac{1}{\sqrt{3}} \cdot \frac{1}{2}, 0)$$

$$= (\pm \frac{1}{2\sqrt{3}}, 0)$$

$$\text{distance between foci} = \text{input} = \frac{1}{\sqrt{3}}$$

$$\text{Equation of } \text{input} \text{ is } x = \pm \frac{a}{e}$$

$$\text{i.e. } x = \pm \frac{\text{input}}{\text{input}} \Rightarrow \text{input}$$

$$\begin{aligned} \text{Distance between directrices} &= 2 \frac{a}{e} \\ &= \text{input} \end{aligned}$$

$$\text{End points of Latera recta} = (ae; \pm \frac{b^2}{a})$$

$$= (\text{input}, \pm \text{input})$$

$$\text{Length of Latus rectum} = \text{input} = \frac{\sqrt{3}}{2}$$

Parametric form  $x = \text{input}; y = \text{input}$

iii)  $4x^2 + 3y^2 = 1$

$$\frac{x^2}{\left(\frac{1}{4}\right)} + \frac{y^2}{\left(\frac{1}{3}\right)} = 1$$

Comparing with

$$\frac{x^2}{a^2} + \frac{y^2}{b^2} = 1$$

$$a^2 = \frac{1}{4}, b^2 = \frac{1}{3}$$

$$a = \frac{1}{2}, b = \frac{1}{\sqrt{3}} \quad b > a$$

therefore  $y$ -axis is major axis

$Y$ -axis (ie  $x = 0$ ) is the major axis

$x$ -axis (ie.  $y = 0$ ) is the minor axis

$$\text{Length of major axis } 2b = 2 \frac{1}{\sqrt{3}}$$

$$\text{length of minor axis } 2a = 2 \frac{1}{2} = 1$$

Centre is at  $O(0, 0)$

$$\text{Vertices } A(\pm a, 0) \equiv (\pm \frac{1}{2}, 0),$$

$$B(0, \pm b) \equiv (0, \pm \frac{1}{\sqrt{3}})$$

Relation between  $a, b, e$

$$a^2 = b^2 (1 - e^2)$$

$$\frac{1}{4} = \frac{1}{3} (1 - e^2)$$

$$\therefore \frac{3}{4} = 1 - e^2$$

$$\therefore e^2 = 1 - \frac{3}{4} \quad e^2 = \frac{1}{4}$$

$$\therefore e = \frac{1}{2} \quad (\because 0 < e < 1)$$

foci S (0, + be) and S' (0, - be)  $\equiv (0, \pm be) =$

$$\left(0, \pm \frac{1}{\sqrt{3}} \cdot \frac{1}{2}\right) = \left(0, \pm \frac{1}{2\sqrt{3}}\right)$$

distance between foci =  $2be = 2\left(\frac{1}{\sqrt{3}}\right)\left(\frac{1}{2}\right) = \frac{1}{\sqrt{3}}$

equation of directrices is  $y = \pm \frac{b}{e}$

$$y = \pm \frac{\left(\frac{1}{\sqrt{3}}\right)}{\left(\frac{1}{2}\right)} = \pm \frac{2}{\sqrt{3}}$$

Distance between directrices  $2\frac{b}{e} = \frac{4}{\sqrt{3}}$

and coordinates of latus rectum.

LL'  $\equiv (\pm \frac{a^2}{b}, be)$

$$= \left(\pm \frac{\left(\frac{1}{4}\right)}{\left(\frac{1}{\sqrt{3}}\right)}, \left(\frac{1}{\sqrt{3}}\right)\left(\frac{1}{2}\right)\right)$$

$$= \left(\pm \frac{\sqrt{3}}{4}, \frac{1}{2\sqrt{3}}\right)$$

Length of latus rectum =  $\frac{2a^2}{b} = \frac{\sqrt{2}}{3}$

Parametric form

$x = a \cos\theta, y = b \sin\theta$

$$x = \frac{1}{2} \cos\theta, y = \frac{1}{\sqrt{3}} \sin\theta$$

iv)  $4x^2 + 9y^2 - 16x + 54y + 61 = 0$

By the method of completing square the above equation becomes  $4(x-2)^2 + 9(y+3)^2 = 36$

That is  $\frac{(x-2)^2}{9} + \frac{(y+3)^2}{4} = 1$

Comparing with standard equation  $\frac{x^2}{a^2} + \frac{y^2}{b^2} = 1$

$a^2 = 9 ; b^2 = 4$

$a = 3 ; b = 2 (a > b)$

$Y = 0$  ie.  $y + 3 = 0$  is the major axis and

$X = 0$  ie.  $x - 2 = 0$  is the minor axis.

Centre  $(X = 0, Y = 0) \equiv (x - 2 = 0, y + 3 = 0) \equiv (2, -3)$

Vertices  $A(x - 2 = \pm 3, y + 3 = 0) \equiv (2 \pm 3, -3)$  i.e.  $A(5, -3)$  and  $A'(-1, -3)$

$B(x - 2 = 0, y + 3 = \pm 2) \equiv (2, -3 \pm 2)$

i.e.  $B(2, -1)$  and  $B'(2, -5)$

$A(5, -3), A'(-1, -3), B(2, -1), B'(2, -5)$

Length of major axis  $(2a) = 2(3) = 6$

Length of minor axis  $(2b) = 2(2) = 4$

$b^2 = a^2(1 - e^2)$

$\therefore 4 = 9(1 - e^2) \therefore \frac{4}{9} = 1 - e^2 \therefore e^2 = 1 - \frac{4}{9}$

$e^2 = \frac{5}{9}$  that is  $e = \pm \frac{\sqrt{5}}{3}$

but  $0 < e < 1$  therefore  $e = \frac{\sqrt{5}}{3}$

Foci  $S\left(x - 2 = 3\frac{\sqrt{5}}{3}, y + 3 = 0\right) \equiv (2 + \sqrt{5}, -3)$

$S'\left(x - 2 = -3\frac{\sqrt{5}}{3}, y + 3 = 0\right) \equiv (2 - \sqrt{5}, -3)$

Distance between foci =  $2\sqrt{5}$

Equation of directrix  $x - 2 = \pm \frac{3}{\left(\frac{\sqrt{5}}{3}\right)}$

that is  $x = 2 \pm \frac{9}{\sqrt{5}}$

distance between directrix =  $2\frac{a}{e} = 2\left(\frac{9}{\sqrt{5}}\right) = \frac{18}{\sqrt{5}}$

coordinates of end point of latera recta

$$L \left( ae, \frac{b^2}{a} \right) = \left( 3 \times \frac{\sqrt{5}}{3}, \frac{(2)^2}{3} \right) = \left( \sqrt{5}, \frac{4}{3} \right)$$

$$L' \left( ae, -\frac{b^2}{a} \right) = \left( \sqrt{5}, -\frac{4}{3} \right)$$

$$\text{Length of latus rectum} = \frac{2b^2}{a} = 2 \left( \frac{4}{3} \right) = \frac{8}{3}$$

Parametric form  $X = 3 \cos\theta$ ,  $Y = 2 \sin\theta$

That is  $x - 2 = 3 \cos\theta$ ,  $y + 3 = 2 \sin\theta$

i.e.  $x = 2 + 3\cos\theta$ ,  $y = -3 + 2\sin\theta$

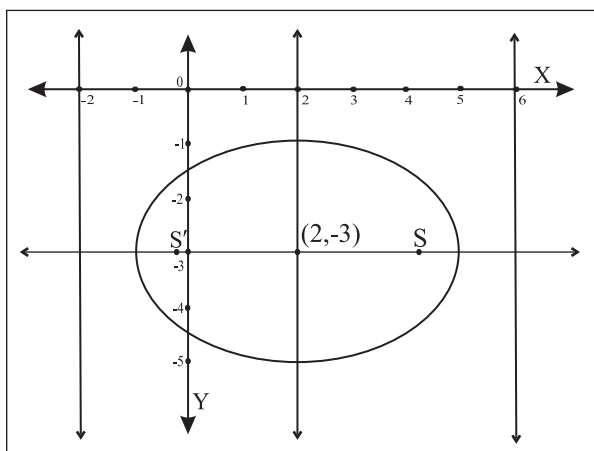

Fig. 7.20

**Ex. 2)** Find the equation of an ellipse having vertices  $(\pm 13, 0)$  and foci  $(\pm 5, 0)$

**Solution :** Since vertices and foci are on the x-axis, the equation of an ellipse will be of the

$$\text{form } \frac{x^2}{a^2} + \frac{y^2}{b^2} = 1 (a > b)$$

$$\text{Vertices } (\pm 13, 0) = (\pm a, 0) \Rightarrow a = 13$$

$$\text{Foci } (\pm 5, 0) = (\pm ae, 0) \Rightarrow ae = 5$$

$$\therefore e = \frac{5}{13}$$

$$\text{We know } b^2 = a^2 (1 - e^2) = a^2 - a^2 e^2$$

$$= (13)^2 - (5)^2 = 169 - 25 = 144$$

$$\text{Equation of the ellipse is } \frac{x^2}{169} + \frac{y^2}{144} = 1.$$

**Ex. 3)** Find the eccentricity of an ellipse whose length of the latus rectum is one third of its minor axis.

**Solution :**

$$\text{Length of latus rectum} = \frac{1}{3} (\text{minor axis})$$

$$\frac{2b^2}{a} = \frac{1}{3}(2b) \text{ that is } b = \frac{1}{3}a$$

$$\text{We know that } b^2 = a^2 (1 - e^2)$$

$$\frac{1}{9} a^2 = a^2 (1 - e^2)$$

$$\frac{1}{9} = 1 - e^2 \quad \therefore e^2 = 1 - \frac{1}{9}$$

$$e^2 = \frac{8}{9} \text{ that is } e = \pm \frac{2\sqrt{2}}{3}$$

$$\text{but } 0 < e < 1 \quad \therefore e = \frac{2\sqrt{2}}{3}$$

**Activity :**

Find the equation of an ellipse whose major axis is on the X-axis and passes through the points  $(4, 3)$  and  $(6, 2)$

**Solution :**

$$\text{Let equation an ellipse } \frac{x^2}{a^2} + \frac{y^2}{b^2} = 1,$$

$a > b$ , since major axis is the X-axis.

Also ellipse passes through points  $(4, 3)$  and  $(6, 2)$

$$\therefore \frac{(4)^2}{a^2} + \frac{(3)^2}{b^2} = 1 \text{ and } \frac{(6)^2}{a^2} + \frac{(2)^2}{b^2} = 1$$

Solve these equations simultaneous to set  $a^2$  and  $b^2$ .

### 7.2.3 Special cases of an ellipse:

Consider the standard ellipse  $\frac{x^2}{a^2} + \frac{y^2}{b^2} = 1$  where

$$b^2 = a^2 (1 - e^2) \text{ and } a > b.$$

As  $a \rightarrow b$  ( $b > 0$ ) then observe that  $e \rightarrow 0$  and shape of the ellipse is more rounded. Thus when  $a = b$  the ellipse reduces to a circle of radius  $a$  and two foci coincides with the centre .

**7.2.4 Tangent to an ellipse :**

A straight line which intersects the curve ellipse in two coincident point is called a tangent to the ellipse

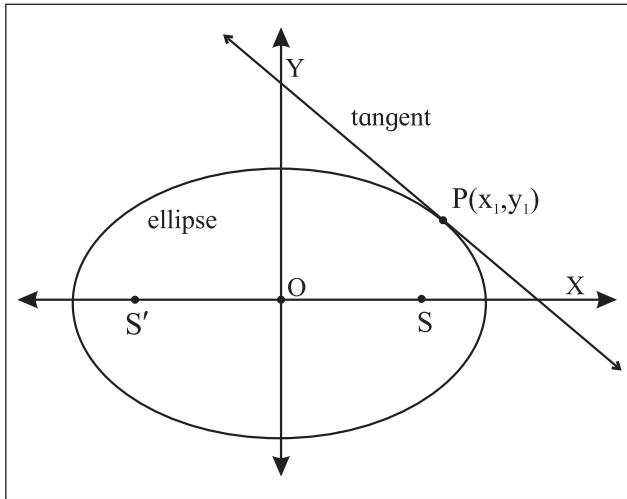

**Fig. 7.21**

To find the equation of tangent to the ellipse.

$\frac{x^2}{a^2} + \frac{y^2}{b^2} = 1$  at the point  $P(x_1, y_1)$  on it. Hence, to obtain the equation of tangent at  $P(\theta_1)$ .

We need to know the slope of the tangent at  $P(x_1, y_1)$ . From the theory of derivative of a function, the slope of the tangent is  $\frac{dy}{dx}$  at  $(x_1, y_1)$

The equation of ellipse is  $\frac{x^2}{a^2} + \frac{y^2}{b^2} = 1$

differentiate both sides with respect to  $x$

We get  $\frac{2x}{a^2} + \frac{2y}{b^2} \frac{dy}{dx} = 0$

$\therefore \frac{dy}{dx} = -\frac{b^2 x}{a^2 y}$

$\therefore \left[ \frac{dy}{dx} \right]_{(x_1, y_1)} = -\frac{b^2}{a^2} \frac{x_1}{y_1} = \text{slope of the tangent at } P(x_1, y_1)$ .

$\therefore$  Equation of the tangent (by slope point form)

at  $P(x_1, y_1)$  is  $y - y_1 = -\frac{b^2}{a^2} \frac{x_1}{y_1} (x - x_1)$

$a^2 y_1 (y - y_1) = -b^2 x_1 (x - x_1)$

$a^2 y_1 y - a^2 y_1^2 = -b^2 x_1 x + b^2 x_1^2$

$b^2 x_1 x + a^2 y_1 y = b^2 x_1^2 + a^2 y_1^2$

Dividing by  $a^2 b^2$

$\frac{xx_1}{a^2} + \frac{yy_1}{b^2} = \frac{x_1^2}{a^2} + \frac{y_1^2}{b^2}$

Now  $P(x_1, y_1)$  lies on the ellipse  $\frac{x_1^2}{a^2} + \frac{y_1^2}{b^2} = 1$

$\therefore \frac{xx_1}{a^2} + \frac{yy_1}{b^2} = 1 \dots\dots\dots(1)$

This is the equation of the tangent at  $P(x_1, y_1)$  on it

Now,  $\theta_1$  is the parameter of point P

$\therefore P(x_1, y_1) = (a \cos\theta_1, b \sin\theta_1)$  that is

$x_1 = a \cos\theta_1, y_1 = b \sin\theta_1$

Substituting these values in equation (1),

we get  $\frac{x a \cos\theta_1}{a^2} + \frac{y b \sin\theta_1}{b^2} = 1$

$\frac{x \cos\theta_1}{a} + \frac{y \sin\theta_1}{b} = 1$

is the required equation of the tangent at  $P(\theta_1)$ .

**7.2.5 Condition for tangency**

To find the condition that the line  $y = mx + c$  is tangent to the ellipse  $\frac{x^2}{a^2} + \frac{y^2}{b^2} = 1$ . Also to find the point of contact.

Equation of the line is  $y = mx + c$

that is  $mx - y + c = 0 \dots\dots(1)$

equation of the tangent at  $P(x_1, y_1)$  to the ellipse

$$\frac{x^2}{a^2} + \frac{y^2}{b^2} = 1 \text{ is } \frac{xx_1}{a^2} + \frac{yy_1}{b^2} = 1.$$

that is  $\frac{x_1}{a^2}x + \frac{y_1}{b^2}y - 1 = 0 \dots (2)$

If the line given by equation (1) is a tangent to the ellipse at  $P(x_1, y_1)$ .

Comparing coefficients of like terms in equation (1) and (2)

we get,  $\frac{\left(\frac{x_1}{a^2}\right)}{m} = \frac{\left(\frac{y_1}{b^2}\right)}{1} = -\frac{1}{c}$

$$\therefore \frac{\left(\frac{x_1}{a^2}\right)}{m} = \frac{-1}{c} \text{ and } \frac{\left(\frac{y_1}{b^2}\right)}{-1} = \frac{-1}{c}$$

$$\therefore \frac{x_1}{a^2m} = \frac{-1}{c} \text{ and } \frac{y_1}{b^2} = \frac{1}{c}$$

$$\therefore x_1 = -\frac{a^2m}{c} \text{ and } y_1 = \frac{b^2}{c}$$

$P(x_1, y_1)$  lies on the ellipse  $\frac{x^2}{a^2} + \frac{y^2}{b^2} = 1$

$$\therefore \frac{x_1^2}{a^2} + \frac{y_1^2}{b^2} = 1$$

$$\therefore \frac{\left(-\frac{a^2m}{c}\right)^2}{a^2} + \frac{\left(\frac{b^2}{c}\right)^2}{b^2} = 1$$

$$\therefore \frac{a^4m^2}{c^2} + \frac{b^4}{c^2} = 1$$

$$\therefore \frac{a^2m^2}{c^2} + \frac{b^2}{c^2} = 1$$

$$\therefore a^2m^2 + b^2 = c^2$$

i.e.  $c^2 = a^2m^2 + b^2$

$$\therefore c = \pm\sqrt{a^2m^2 + b^2} \text{ is the condition for tangency.}$$

The equation of tangent to the ellipse in terms of slope is

$$y = mx \pm \sqrt{a^2m^2 + b^2}, P\left(\frac{-a^2m}{c}, \frac{b^2}{c}\right)$$

Thus the line  $y = mx + c$  is tangent to the ellipse

$$\frac{x^2}{a^2} + \frac{y^2}{b^2} = 1 \text{ if } c = \pm\sqrt{a^2m^2 + b^2} \text{ and the point of contact is } \left(-\frac{a^2m}{c}, \frac{b^2}{c}\right).$$

### 7.2.6 Tangents from a point to the ellipse

Two tangents can be drawn to the ellipse from any point outside the ellipse.

Let  $P(x_1, y_1)$  be any point in plane of the ellipse.

The equation of tangent, with slope  $m$  to the ellipse is

$$y = mx \pm \sqrt{a^2m^2 + b^2}.$$

This pass through  $(x_1, y_1)$

$$\therefore y_1 = mx_1 \pm \sqrt{a^2m^2 + b^2}$$

$$\therefore y_1 - mx_1 = \pm\sqrt{a^2m^2 + b^2}, \text{ we solve it for } m.$$

Squaring on both sides and simplifying we get the quadratic equation in  $m$ .

$$(x_1^2 - a^2)m^2 - 2x_1y_1m + (y_1^2 - b^2) = 0$$

it has two roots say,  $m_1$  and  $m_2$  which are the slopes of two tangents.

Thus, in general, two tangents can be drawn to a ellipse from a given point in its plane.

$$\begin{aligned} \text{Sum of the roots} &= m_1 + m_2 = \frac{-(-2x_1y_1)}{(x_1^2 - a^2)} \\ &= \frac{(2x_1y_1)}{(x_1^2 - a^2)} \end{aligned}$$

$$\text{Product of roots} = m_1 m_2 = \frac{(y_1^2 - b^2)}{(x_1^2 - a^2)}$$

### 7.2.7 Locus of point of intersection of perpendicular tangents

If the tangent drawn from P are mutually perpendicular then we have  $m_1 m_2 = -1$

$$\therefore \frac{y_1^2 - b^2}{x_1^2 - a^2} = 1$$

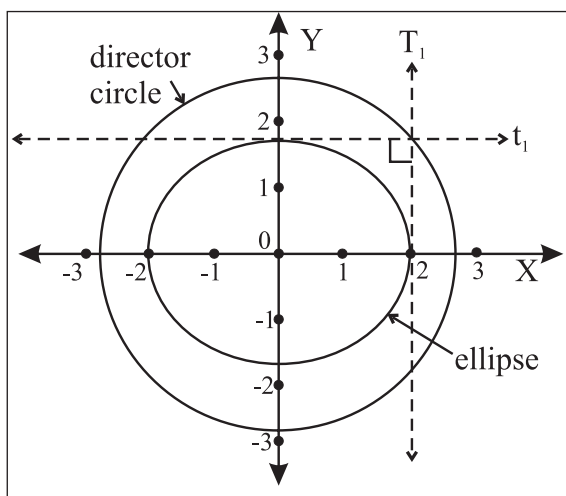

Fig. 7.22

$$\therefore (y_1^2 - b^2) = -(x_1^2 - a^2)$$

$$\therefore x_1^2 + y_1^2 = a^2 + b^2$$

This is the equation of standard circle with centre at origin and radius  $\sqrt{a^2 + b^2}$  which is called the director circle of the ellipse.

### 7.2.8 Auxiliary circle, director circle of the ellipse

For the standard ellipse  $\frac{x^2}{a^2} + \frac{y^2}{b^2} = 1 (a > b)$  the circle drawn with major axis as  $a$  diameter is called the auxiliary circle of the ellipse and its equation is  $x^2 + y^2 = a^2$ .

The locus of point of intersection of perpendicular tangents to the ellipse  $\frac{x^2}{a^2} + \frac{y^2}{b^2} = 1$  is called the director circle of the ellipse and its equation is  $x^2 + y^2 = a^2 + b^2$ .

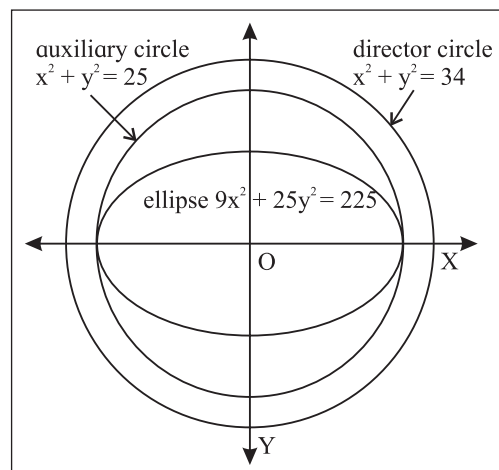

Fig. 7.23

### SOLVED EXAMPLE

**Ex. 1)** Find the equation of tangent to the ellipse

- i)  $\frac{x^2}{8} + \frac{y^2}{6} = 1$  at the point  $(2, \sqrt{3})$ .
- ii)  $\frac{x^2}{25} + \frac{y^2}{9} = 1$  at the point whose eccentric angle is  $\pi/4$ .

**Solution :**

- i) Equation of the ellipse is  $\frac{x^2}{8} + \frac{y^2}{6} = 1$   
comparing it with  $\frac{x^2}{a^2} + \frac{y^2}{b^2} = 1$   
 $a^2 = 8$  and  $b^2 = 6$ .

Tangent is drawn to the ellipse at point  $(2, \sqrt{3})$  on it. Say  $(x_1, y_1) \equiv (2, \sqrt{3})$ .

We know that,

the equation of tangent to the ellipse

$$\frac{x^2}{a^2} + \frac{y^2}{b^2} = 1 \text{ at point } (x_1, y_1) \text{ on it is}$$

$$\frac{xx_1}{a^2} + \frac{yy_1}{b^2} = 1$$

$$\therefore \frac{x(2)}{8} + \frac{y(\sqrt{3})}{6} = 1$$

$$\frac{x}{4} + \frac{\sqrt{3}y}{6} = 1$$

i.e.  $6x + 4\sqrt{3}y = 24$

i.e.  $3x + 2\sqrt{3}y = 12$

Thus required equation of tangent is

$$3x + 2\sqrt{3}y = 12.$$

ii) Equation of ellipse is  $\frac{x^2}{25} + \frac{y^2}{9} = 1$

comparing it with  $\frac{x^2}{a^2} + \frac{y^2}{b^2} = 1$

$$a^2 = 25 \text{ and } b^2 = 9.$$

eccentric angle  $\theta = \frac{\pi}{4}$ .

By parametric form equation of tangent is

$$\frac{x \cdot \cos \theta}{a} + \frac{y \cdot \sin \theta}{b} = 1$$

i.e.  $\frac{x \cdot \cos \frac{\pi}{4}}{5} + \frac{y \cdot \sin \frac{\pi}{4}}{3} = 1$

$$\frac{x \cdot \frac{1}{\sqrt{2}}}{5} + \frac{y \cdot \frac{1}{\sqrt{2}}}{3} = 1$$

$$\frac{x}{5\sqrt{2}} + \frac{y}{3\sqrt{2}} = 1$$

$$3x + 5y = 15\sqrt{2}$$

**Ex. 2)** Show that the line  $2x + 3y = 12$  is tangent to the ellipse  $4x^2 + 9y^2 = 72$ .

**Solution :** Equation of the ellipse is  $4x^2 + 9y^2 = 72$

i.e.  $\frac{x^2}{18} + \frac{y^2}{8} = 1$

comparing it with  $\frac{x^2}{a^2} + \frac{y^2}{b^2} = 1$

$$a^2 = 18 \text{ and } b^2 = 8$$

Equation of line is  $2x + 3y = 12$

i.e.  $y = -\frac{2}{3}x + 4$

comparing it with  $y = mx + c$

$$m = -\frac{2}{3} \text{ and } c = 4$$

We know that,

if the line  $y = mx + c$  is tangent to the ellipse

$$\frac{x^2}{a^2} + \frac{y^2}{b^2} = 1 \text{ then } c^2 = a^2 m^2 + b^2.$$

Here  $c^2 = (4)^2 = 16$  and

$$a^2 m^2 + b^2 = (18) \left(-\frac{2}{3}\right)^2 + (8) = (18) \left(\frac{4}{9}\right) + 8 = (2)(4) + 8 = 16$$

hence the given line is tangent to the given ellipse.

**Ex. 3)** Find the equations of tangents to the ellipse  $4x^2 + 9y^2 = 36$  passing through the point  $(2, -2)$ .

**Solution :** Equation of the ellipse is  $4x^2 + 9y^2 = 36$

i.e.  $\frac{x^2}{9} + \frac{y^2}{4} = 1$

comparing it with  $\frac{x^2}{a^2} + \frac{y^2}{b^2} = 1$

$$a^2 = 9 \text{ and } b^2 = 4$$

Equation of tangent in terms of slope  $m$ , to the ellipse is

$$y = mx \pm \sqrt{a^2 m^2 + b^2}$$

Point  $(2, -2)$  lies on the tangent

$$\therefore (-2) = m(2) \pm \sqrt{9m^2 + 4}$$

$$\therefore -2m - 2 = \pm \sqrt{9m^2 + 4}$$

squaring both sides

$$4m^2 + 8m + 4 = 9m^2 + 4$$

$$-5m^2 + 8m = 0$$

$$m(-5m + 8) = 0 \Rightarrow m = 0 \text{ or } m = 8/5$$

Equation of tangent line having slope  $m$  and passing through pt  $(2, -2)$  is  $y + 2 = m(x - 2)$

i.e.  $y + 2 = 0(x - 2)$  or  $y + 2 = \frac{8}{5}(x - 2)$

$$y + 2 = 0$$

$$5y + 10 = 8x - 16$$

$$8x - 5y - 26 = 0$$

Thus equation of tangents are  $y + 2 = 0$  and  $8x - 5y - 26 = 0$

**EXERCISE 7.2**

- Find the (i) lengths of the principal axes. (ii) co-ordinates of the foci (iii) equations of directrices (iv) length of the latus rectum (v) distance between foci (vi) distance between directrices of the ellipse:  
(a)  $x^2/25 + y^2/9 = 1$       (b)  $3x^2 + 4y^2 = 12$   
(c)  $2x^2 + 6y^2 = 6$       (d)  $3x^2 + 4y^2 = 1$ .
- Find the equation of the ellipse in standard form if
  - eccentricity =  $3/8$  and distance between its foci =  $6$ .
  - the length of major axis  $10$  and the distance between foci is  $8$ .
  - distance between directrix is  $18$  and eccentricity is  $1/3$ .
  - minor axis is  $16$  and eccentricity is  $1/3$ .
  - the distance between foci is  $6$  and the distance between directrix is  $50/3$ .
  - The latus rectum has length  $6$  and foci are  $(\pm 2, 0)$ .
  - passing through the points  $(-3, 1)$  and  $(2, -2)$
  - the dist. between its directrix is  $10$  and which passes through  $(-\sqrt{5}, 2)$
  - eccentricity is  $2/3$  and passes through  $(2, -5/3)$ .
- Find the eccentricity of an ellipse, if the length of its latus rectum is one third of its minor axis.
- Find the eccentricity of an ellipse if the distance between its directrix is three times the distance between its foci.
- Show that the product of the lengths of the perpendicular segments drawn from the foci to any tangent line to the ellipse  $x^2/25 + y^2/16 = 1$  is equal to  $16$ .
- A tangent having slope  $-1/2$  to the ellipse  $3x^2 + 4y^2 = 12$  intersects the X and Y axes in the points A and B respectively. If O is the origin, find the area of the triangle.
- Show that the line  $x - y = 5$  is a tangent to the ellipse  $9x^2 + 16y^2 = 144$ . Find the point of contact.
- Show that the line  $8y + x = 17$  touches the ellipse  $x^2 + 4y^2 = 17$ . Find the point of contact.
- Determine whether the line  $x + 3y\sqrt{2} = 9$  is a tangent to the ellipse  $x^2/9 + y^2/4 = 1$ . If so, find the co-ordinates of the pt of contact.
- Find k, if the line  $3x + 4y + k = 0$  touches  $9x^2 + 16y^2 = 144$ .
- Find the equation of the tangent to the ellipse (i)  $x^2/5 + y^2/4 = 1$  passing through the point  $(2, -2)$ .
  - $4x^2 + 7y^2 = 28$  from the pt  $(3, -2)$ .
  - $2x^2 + y^2 = 6$  from the point  $(2, 1)$ .
  - $x^2 + 4y^2 = 9$  which are parallel to the line  $2x + 3y - 5 = 0$ .
  - $x^2/25 + y^2/4 = 1$  which are parallel to the line  $x + y + 1 = 0$ .
  - $5x^2 + 9y^2 = 45$  which are  $\perp$  to the line  $3x + 2y + y = 0$ .
  - $x^2 + 4y^2 = 20$ ,  $\perp$  to the line  $4x + 3y = 7$ .
- Find the equation of the locus of a point the tangents from which to the ellipse  $3x^2 + 5y^2 = 15$  are at right angles.

14. Tangents are drawn through a point P to the ellipse  $4x^2 + 5y^2 = 20$  having inclinations  $\theta_1$  and  $\theta_2$  such that  $\tan \theta_1 + \tan \theta_2 = 2$ . Find the equation of the locus of P.
15. Show that the locus of the point of intersection of tangents at two points on an ellipse, whose eccentric angles differ by a constant, is an ellipse.
16. P and Q are two points on the ellipse  $\frac{x^2}{a^2} + \frac{y^2}{b^2} = 1$  with eccentric angles  $\theta_1$  and  $\theta_2$ . Find the equation of the locus of the point of intersection of the tangents at P and Q if  $\theta_1 + \theta_2 = \pi/2$ .
17. The eccentric angles of two points P and Q the ellipse  $4x^2 + y^2 = 4$  differ by  $2\pi/3$ . Show that the locus of the point of intersection of the tangents at P and Q is the ellipse  $4x^2 + y^2 = 16$ .
18. Find the equations of the tangents to the ellipse  $x^2/16 + y^2/9 = 1$ , making equal intercepts on co-ordinate axes.
19. A tangent having slope  $-\frac{1}{2}$  to the ellipse  $3x^2 + 4y^2 = 12$  intersects the X and Y axes in the points A and B respectively. If O is the origin, find the area of the triangle.

### 7.3 Hyperbola



#### Let's Study

- Standard equation of the hyperbola.
- Equation of tangent to the hyperbola.
- condition for tangency.
- auxillary circle and director circle of the hyperbola.

The hyperbola is the intersection of double napped cone with plane parallel to the axis.

The hyperbola is the locus of a point in a plane which moves so that its distance from

a fixed point bears a constant ratio  $e$  ( $e > 1$ ) to its distance from a fixed line. The fixed point is called the focus S and the fixed line is called the directrix d.

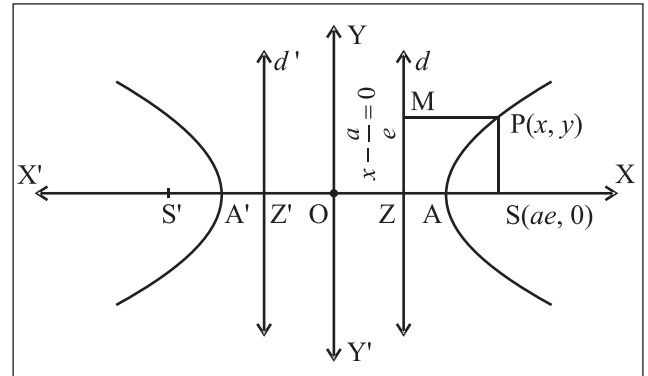

Fig. 7.24

If S is the focus and  $d$  is the directrix not containing the focus and P is the moving point, then  $\frac{PS}{PM} = e$ , where PM is the perpendicular on the directrix.  $e > 1$  called eccentricity of the hyperbola. (Fig. 7.24)

#### 7.3.1 Standard equation of the hyperbola

Let S be the focus,  $d$  be the directrix and  $e$  be the eccentricity of a hyperbola.

Draw SZ perpendicular to directrix. Let A and A' divide the segment SZ internally and externally in the ratio  $e : 1$ . By definition of hyperbola A and A' lie on hyperbola.

Let  $AA' = 2a$ , midpoint O of segment  $AA'$  be the origin. Then  $O \equiv (0,0)$ ,  $A \equiv (a,0)$  and  $A' \equiv (-a,0)$

$$\frac{SA}{AZ} = \frac{e}{1} \quad \left( \frac{SA'}{A'Z} = \frac{-e}{1} \right)$$

therefore  $SA = eAZ$ .

Let  $Z \equiv (k,0)$  and  $S \equiv (h,0)$

By section formula for internal and external division.

$$a = \frac{ek + 1h}{e + 1} \quad \text{also} \quad -a = \frac{ek - 1h}{e - 1}$$

$$ae + a = ek + h \quad \dots (2)$$

$$-ae + a = ek - h \quad \dots (3)$$

Solving these equations, we get

$$k = a/e \quad \text{and} \quad h = ae$$

Focus  $S \equiv (ae, 0)$  and  $Z \equiv (a/e, 0)$

Equation of the directrix is  $x = \frac{a}{e}$

$$\text{That is } x - \frac{a}{e} = 0$$

Let  $P(x,y)$  be a point on the hyperbola.

$SP =$  focal distance

$$= \sqrt{(x-ae)^2 + (y-0)^2} \quad \dots(4)$$

$PM =$  distance of point  $P$  from the directrix

$$= \left| \frac{x - \frac{a}{e}}{\sqrt{1^2 + 0^2}} \right| = \left| x - \frac{a}{e} \right| \quad \dots(5)$$

From (1), (4) and (5)

$$\sqrt{(x-ae)^2 + (y-0)^2} = e \left| x - \frac{a}{e} \right|$$

$$= \sqrt{(x-ae)^2 + (y-0)^2} = |ex - a|$$

Squaring both sides

$$(x-ae)^2 + (y-0)^2 = e^2x^2 - 2aex + a^2$$

$$x^2 - 2aex + a^2e^2 + y^2 = e^2x^2 - 2aex + a^2$$

$$x^2 + a^2e^2 + y^2 = e^2x^2 + a^2$$

$$(1 - e^2)x^2 + y^2 = a^2(1 - e^2)$$

Since  $e > 1$

$$(e^2 - 1)x^2 - y^2 = a^2(e^2 - 1)$$

Dividing both sides by  $a^2(e^2 - 1)$

$$\therefore \frac{x^2}{a^2} - \frac{y^2}{a^2(e^2 - 1)} = 1$$

$$\frac{x^2}{a^2} - \frac{y^2}{b^2} = 1 \quad \text{where } b^2 = a^2(e^2 - 1)$$

This is the standard equation of hyperbola.

Let  $S'$  be  $(-ae, 0)$  and  $d'$  be the line  $x = -\frac{a}{e}$ .

For any point  $P$  on the hyperbola,  $PM'$  is perpendicular on  $d'$  then it can be verified that  $PS' = e PM'$ .

Thus for the hyperbola  $(ae, 0)$  and  $(-ae, 0)$  are two foci and  $x = \frac{a}{e}$  and  $x = -\frac{a}{e}$  are corresponding two directrices.

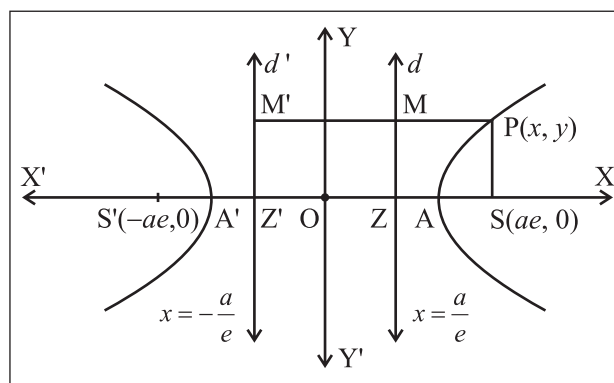

Fig. 7.25

### 7.3.2 Some useful terms of the hyperbola

Equation of the hyperbola  $\frac{x^2}{a^2} - \frac{y^2}{b^2} = 1$

- i) The hyperbola intersects x-axis at  $A(a, 0)$ ,  $A'(-a, 0)$ .
- ii) It does not intersect the y-axis.
- iii) The segment  $AA'$  of length  $2a$  is called the transverse axis and the segment  $BB'$  of length  $2b$  is called the conjugate axis.
- iii) The line segment through the foci of the hyperbola is called the transverse axis and the line segment through centre and perpendicular to transverse axis is the conjugate axis. The transverse axis and conjugate axis together are called principal axes of the hyperbola. In the standard form X axis is the transverse axis and Y axis is the conjugate axis.

iv) latus rectum is the chord passing through the focus which is perpendicular to transverse axis. It is bisected at the focus. There are two latera recta as there are two focii.

**7.3.3 Some Results :**

1) **Distance between directrices i.e. d (dd')** is the same that of distance ZZ' ie. d (ZZ')

$$Z \equiv (a/e, 0) \text{ and } Z' (-a/e, 0)$$

$$\Rightarrow d(dd') = d(zz') = \left| \frac{a}{e} + \frac{a}{e} \right| = 2 \frac{a}{e}$$

2) **Let LSL' be the latus rectum of the hyperbola.**

$$\frac{x^2}{a^2} - \frac{y^2}{b^2} = 1$$

(SL and SL' are the semi latus rectum)

$$\text{Let } L \equiv (ae, l)$$

$$\frac{(ae)^2}{a^2} + \frac{l^2}{b^2} = 1$$

$$e^2 + \frac{l^2}{b^2} = 1$$

$$\frac{l^2}{b^2} = 1 - e^2$$

$$l^2 = b^2 (1 - e^2)$$

$$l^2 = b^2 \left( \frac{b^2}{a^2} \right)$$

$$l^2 = \frac{b^4}{a^2}$$

$$l = \pm \frac{b^2}{a}$$

$$L = \left( ae, \frac{b^2}{a} \right) \text{ and } L' \equiv \left( ae, -\frac{b^2}{a} \right)$$

These are the co-ordinates of end points of latus rectum.

3) **Length of latus rectum** =  $l (LL')$   
 $= l (SL) + l (SL') = \frac{b^2}{a} + \frac{b^2}{a} = \frac{2b^2}{a}$

4) **SP and S'P are the focal distances of the point P on the hyperbola.**

$$SP = e PM \text{ and } S'P = e PM'$$

Difference between the focal distances of point P

$$SP - S'P = e PM - e PM'$$

$$= e (PM - PM')$$

$$= e (MM')$$

$$= e (\text{distance between the directrices})$$

$$= e (2 a/e)$$

$$SP - S'P = 2a = \text{constant}$$

$$= \text{length of major axis ie. transverse axis.}$$

**Difference between the focal distances of point on the hyperbola is the length of transverse axis which is a constant.**

5) A circle drawn with the transverse axis AA' as a diameter is called an auxiliary circle of the hyperbola and its equation is  $x^2 + y^2 = a^2$ .

**Parametric Equation of the Hyperbola**

$$\frac{x^2}{a^2} - \frac{y^2}{b^2} = 1 :$$

Taking the transverse axis AA' as diameter.

Draw a circle with centre at origin and radius

'a' so that its equation is  $x^2 + y^2 = a^2$ . It is called the auxiliary circle of the hyperbola  $\frac{x^2}{a^2} - \frac{y^2}{b^2} = 1 \dots(I)$

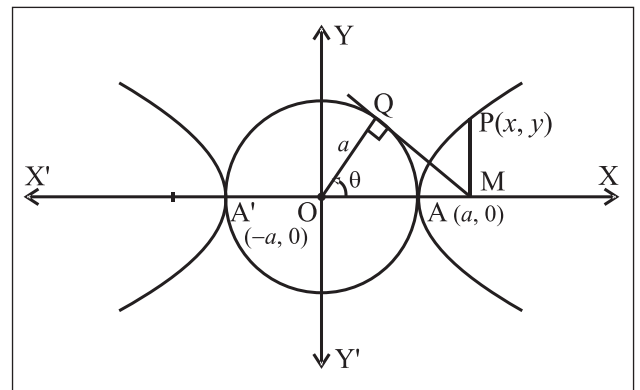

**Fig. 7.26**

Let  $P(x_1, y_1)$  be any point on the hyperbola. Draw  $PM$  perpendicular to  $OX$ . Draw the tangent  $MQ$  touching auxiliary circle at  $Q$ . Point  $Q$  is called the corresponding point of  $P$  on the auxiliary circle.

Let  $m\angle XOQ = \theta$ . Then by trigonometry co-ordinates of  $Q$  are  $(a \cos \theta, a \sin \theta)$ .

Further,

$$x = OM = \frac{OM}{OQ} \cdot OQ = \sec \theta \cdot a = a \sec \theta$$

The point  $P(x, y) = P(a \sec \theta, y)$   $\therefore$   $P$  lies on the hyperbola-(I) therefore.

$$\frac{a^2 \sec^2 \theta}{a^2} - \frac{y^2}{b^2} = 1$$

$$\therefore \frac{y^2}{b^2} = \sec^2 \theta - 1 = \tan^2 \theta$$

$$\therefore \frac{y}{b} = \pm \tan \theta$$

Since  $P$  lies in the first quadrant and angle  $\theta < 90^\circ$ ,  $y$  and  $\tan \theta$  both are positive.

$$\therefore y = b \tan \theta$$

$$\therefore P \equiv P(a \sec \theta, b \tan \theta)$$

Substituting these co-ordinates in the LHS of equation of hyperbola (I), we get

$$\left( x - 2 = 3 \frac{\sqrt{5}}{3}, y + 3 = 0 \right) = \sec^2 \theta - \tan^2 \theta = 1$$

$\therefore$  for any value of  $\theta$ , the point  $(a \sec \theta, b \tan \theta)$  always lies on the hyperbola.

Let us denote this point by  $P(\theta) = P(a \sec \theta, b \tan \theta)$  where  $\theta$  is called parameter also called the eccentric angle of point  $P$ .

The equations  $x = a \sec \theta, y = b \tan \theta$  are called parametric equations of the hyperbola.

### 7) Other standard form of hyperbola.

$\frac{y^2}{b^2} - \frac{x^2}{a^2} = 1$  is called the conjugate hyperbola of the hyperbola  $\frac{x^2}{a^2} - \frac{y^2}{b^2} = 1$

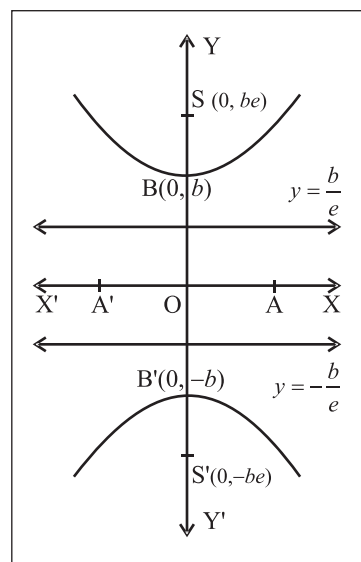

Fig. 2.27

1	Standard equation	$\frac{x^2}{a^2} - \frac{y^2}{b^2} = 1$	$\frac{y^2}{b^2} - \frac{x^2}{a^2} = 1$
2	Centre	O(0,0)	O(0,0)
3	Axes of symmetry	Both x axis and y axis	Both x axis and y axis
4	Vertices	A(a,0) A'(-a,0) B(0,b) B'(0,-b)	A(a,0) A'(-a,0) B(0,b) B'(0,-b)
5	Major axis ie. transverse axis and minor axis ie. conjugate axis	X axis and Y axis	Y axis and X axis
6	Length of transverse axis	2a	2b
7	Length of conjugate axis	2b	2a

8	Foci	$S(ae, 0)$ $S(-ae, 0)$	$S(0, be)$ $S(0, -be)$
9	Distance between foci	$2ae$	$2be$
10	Equation of directrix	$x = \frac{a}{e}$ and $x = -\frac{a}{e}$	$y = +\frac{b}{e}$ and $y = -\frac{b}{e}$
11	Distance between the directrices	$\frac{2a}{e}$	$\frac{2b}{e}$
12	end points of latus rectum	$L = \left( ae, \frac{b^2}{a} \right)$ and $L' = \left( ae, -\frac{b^2}{a} \right)$	$L \equiv \left( \frac{a^2}{b}, be \right)$ and $L' \equiv \left( \frac{a^2}{b}, -be \right)$
13	Length of latus rectum	$\frac{2b^2}{a}$	$\frac{2a^2}{b}$
14	Parametric form	$x = a \sec\theta$ and $y = b \tan\theta$	$x = a \tan\theta$ and $y = b \sec\theta$
15	Equation of tangent at vertex	$x = a$ , $x = -a$	$y = b$ , $y = -b$
16	Sum of Focal distance of a point $P(x_1, y_1)$	$2a$ (length of major axis ie. transverse axis)	$2b$ (length of minor axis ie. conjugate axis)

### SOLVED EXAMPLE

**Ex. 1)** Find the length of transverse axis, length of conjugate axis, the eccentricity, the co-ordinates of foci, equations of directrices and the length of latus rectum of the hyperbola

$$(i) \frac{x^2}{4} - \frac{y^2}{12} = 1 \quad (ii) \frac{y^2}{9} - \frac{x^2}{16} = 1$$

**Solution :**

(i) The equation of the hyperbola is  $\frac{x^2}{4} - \frac{y^2}{12} = 1$ .

Comparing this with equation  $\frac{x^2}{a^2} - \frac{y^2}{b^2} = 1$

We have  $a^2 = 4$ ,  $b^2 = 12$

$\therefore a = 2$ ,  $b = 2\sqrt{3}$

Length of transverse axis =  $2a = 2(2) = 4$

Length of conjugate axis =  $2b = 2(2\sqrt{3})$

=  $4\sqrt{3}$

Eccentricity  $b^2 = a^2(e^2 - 1)$

$$\therefore e = \frac{\sqrt{a^2 + b^2}}{a} = \frac{\sqrt{4 + 12}}{2} = \frac{\sqrt{16}}{2} = \frac{4}{2} = 2$$

( $\because e > 0$ )

$ae = 2(2) = 4$

$\therefore$  foci  $(\pm ae, 0)$  are  $(\pm 4, 0)$

$\frac{a}{e} = \frac{2}{2} = 1$

$\therefore$  the equations of directrices  $x = \pm \frac{a}{e}$  are  $x = \pm 1$ .

Length of latus rectum =  $\frac{2b^2}{a} = \frac{2(12)}{2} = 12$

(ii) The equation of the hyperbola is  $\frac{y^2}{9} - \frac{x^2}{16} = 1$

Comparing this with the equation

$$\frac{y^2}{b^2} - \frac{x^2}{a^2} = 1$$

We have  $a^2 = 16$ ,  $b^2 = 9$

$\therefore a = 4, b = 3$

Length of transverse axis =  $2b = 2(3) = 6$

Length of conjugate axis =  $2a = 2(4) = 8$

Eccentricity  $a^2 = b^2 (e^2 - 1)$

$\therefore e = \frac{\sqrt{a^2 + b^2}}{b} = \frac{\sqrt{16 + 9}}{3} = \frac{\sqrt{25}}{3} = \frac{5}{3}$   
 ( $\because e > 0$ )

$be = 3 \left( \frac{5}{3} \right) = 5$

$\therefore$  focii  $(0, \pm be)$  are  $(0, \pm 5)$

$\frac{b}{e} = \frac{3}{5/3} = \frac{9}{5}$

$\therefore$  the equations of directrices  $y = \pm \frac{b}{e}$  are  
 $y = \pm \frac{9}{5}$ .

Length of latus rectum =  $\frac{2a^2}{b} = \frac{2(16)}{3} = \frac{32}{3}$

**Ex. 2)** Find the equation of the hyperbola with the centre at the origin, transverse axis 12 and one of the foci at  $(3\sqrt{5}, 0)$

**Solution :**

Let the equation of the required hyperbola be

$\frac{x^2}{a^2} - \frac{y^2}{b^2} = 1$  .....(1)

Length of transverse axis =  $2a = 12$

$\therefore a = 6 \therefore a^2 = 36$

Since focus  $(ae, 0)$  is  $(3\sqrt{5}, 0)$

$\therefore ae = 3\sqrt{5}$

$\therefore a^2 e^2 = 45$

$\therefore a^2 + b^2 = 45$

$\therefore 36 + b^2 = 45$

$\therefore b^2 = 9$

Then from (1), the equation of the required hyperbola is

$\frac{x^2}{36} - \frac{y^2}{9} = 1$

**Ex. 3)** Find the equation of the hyperbola referred to its principal axes whose distance between directrices is  $\frac{18}{5}$  and eccentricity is  $\frac{5}{3}$ .

**Solution :**

The equation of the hyperbola referred to its principal axes be

$\frac{x^2}{a^2} - \frac{y^2}{b^2} = 1$  .....(1)

Since eccentricity =  $e = \frac{5}{3}$  and distance between

directrices =  $\frac{2a}{e} = \frac{18}{5}$

$\therefore \frac{a}{e} = \frac{9}{5}$

$\therefore a = \frac{9}{5}e = \frac{9}{5} \times \frac{5}{3}, a = 3$

$\therefore a^2 = 9$

Now  $b^2 = a^2 (e^2 - 1) = 9 \left( \frac{25}{9} - 1 \right)$

$= 9 \times \frac{16}{9} = 16$

Then from (1), the equation of the required

hyperbola is  $\frac{x^2}{9} - \frac{y^2}{16} = 1$

**7.3.4 Tangent to a hyperbola:**

A straight line which intersects the curve hyperbola in two coincident points is called a tangent of the hyperbola

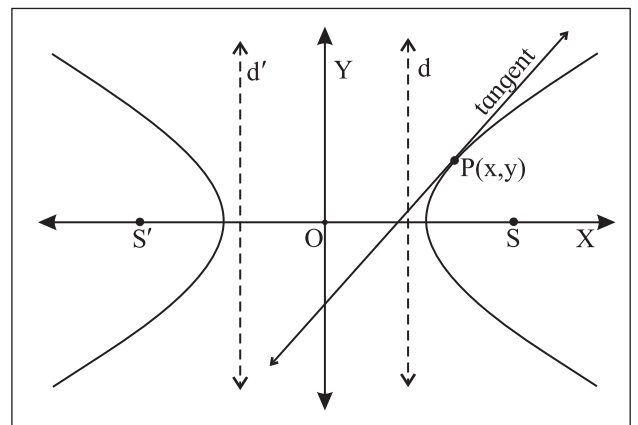

**Fig. 7.28**

**Tangent at a point on a hyperbola.**

To find the equation of tangent to the hyperbola.

$$\frac{x^2}{a^2} - \frac{y^2}{b^2} = 1 \text{ at the point } P(x_1, y_1) \text{ on it. Hence,}$$

to obtain the equation of tangent at  $P(\theta_1)$ .

We need to know the slope of the tangent at  $P(x_1, y_1)$ . From the theory of derivative of a function

the slope of the tangent is  $\frac{dy}{dx}$  at  $(x_1, y_1)$

and here  $\frac{dy}{dx} (x_1, y_1) = m$

The equation of hyperbola is  $\frac{x^2}{a^2} - \frac{y^2}{b^2} = 1$

differentiate both sides with respect to  $x$

We get  $\frac{2x}{a^2} - \frac{2y}{b^2} \frac{dy}{dx} = 0$

$$\therefore \frac{dy}{dx} = \left(-\frac{2x}{a^2}\right) \left(-\frac{b^2}{2y}\right) = \frac{b^2 x}{a^2 y}$$

$$\therefore \left(\frac{dy}{dx}\right)_{(x_1, y_1)} = \frac{b^2 x_1}{a^2 y_1} = \text{slope of the tangent at}$$

$P(x_1, y_1)$

$\therefore$  Equation of the tangent to the hyperbola

at  $P(x_1, y_1)$  is  $y - y_1 = \frac{b^2 x_1}{a^2 y_1} (x - x_1)$

$$a^2 y_1 (y - y_1) = b^2 x_1 (x - x_1)$$

$$a^2 y_1 y - a^2 y_1^2 = b^2 x_1 x - b^2 x_1^2$$

$$b^2 x_1 x + a^2 y_1 y = b^2 x_1^2 + a^2 y_1^2$$

Dividing by  $a^2 b^2$

$$\frac{xx_1}{a^2} - \frac{yy_1}{b^2} = \frac{x_1^2}{a^2} - \frac{y_1^2}{b^2}$$

Now  $P(x_1, y_1)$  lies on the hyperbola  $\frac{x^2}{a^2} - \frac{y^2}{b^2} = 1$

$$\therefore \frac{x_1^2}{a^2} - \frac{y_1^2}{b^2} = 1$$

$$\therefore \frac{xx_1}{a^2} - \frac{yy_1}{b^2} = 1 \dots\dots\dots(1)$$

is the equation of the tangent at  $P(x_1, y_1)$  on it

Now,  $\theta_1$  is the parameter of point  $P$

$\therefore P(x_1, y_1) = (a \sec\theta_1, b \tan\theta_1)$  that is

$$x_1 = a \sec\theta_1, y_1 = b \tan\theta_1$$

Substituting these values in equation (1),

we get  $\frac{x a \sec\theta_1}{a^2} - \frac{y b \tan\theta_1}{b^2} = 1$

$$\frac{x \sec\theta_1}{a} - \frac{y \tan\theta_1}{b} = 1$$

$$\text{i.e. } \left(\frac{\sec\theta_1}{a}\right)x - \left(\frac{\tan\theta_1}{b}\right)y = 1$$

is the required equation of the tangent at  $P(\theta_1)$ .

**7.3.5 Condition for tangency**

To find the condition that the line  $y = mx + c$

is tangent to the hyperbola  $\frac{x^2}{a^2} - \frac{y^2}{b^2} = 1$ . Also to

find the point of contact.

Equation of the line is  $y = mx + c$

that is  $mx - y + c = 0 \dots(1)$

equation of the tangent at  $P(x_1, y_1)$  to the hyperbola

$$\frac{x^2}{a^2} - \frac{y^2}{b^2} = 1 \text{ is } \frac{xx_1}{a^2} - \frac{yy_1}{b^2} = 1.$$

that is  $\frac{x_1}{a^2}x - \frac{y_1}{b^2}y - 1 = 0 \dots(2)$

If the line given by equation (1) is a tangent to the hyperbola at  $(x_1, y_1)$ .

Comparing similar terms in equation (1) and (2)

we get  $\frac{\left(\frac{x_1}{a^2}\right)}{m} = \frac{\left(-\frac{y_1}{b^2}\right)}{-1} = \frac{-1}{c}$

$$\therefore \frac{\left(\frac{x_1}{a^2}\right)}{m} = \frac{-1}{c} \text{ and } \frac{\left(-\frac{y_1}{b^2}\right)}{-1} = \frac{-1}{c}$$

$$\therefore \frac{x_1}{a^2 m} = \frac{-1}{c} \quad \text{and} \quad \frac{y_1}{b^2} = -\frac{1}{c}$$

$$\therefore x_1 = -\frac{a^2 m}{c} \quad \text{and} \quad y_1 = \frac{-b^2}{c}$$

P(x<sub>1</sub>, y<sub>1</sub>) lies on the hyperbola

$$\therefore \frac{x_1^2}{a^2} - \frac{y_1^2}{b^2} = 1$$

$$\therefore \frac{\left(-\frac{a^2 m}{c}\right)^2}{a^2} - \frac{\left(\frac{-b^2}{c}\right)^2}{b^2} = 1$$

$$\therefore \frac{\left(\frac{a^4 m^2}{c^2}\right)}{a^2} - \frac{\left(\frac{b^4}{c^2}\right)}{b^2} = 1$$

$$\therefore \frac{a^2 m^2}{c^2} - \frac{b^2}{c^2} = 1$$

$$\therefore c^2 = a^2 m^2 - b^2$$

$c = \pm \sqrt{a^2 m^2 - b^2}$  is called the condition of tangency.

Thus the line  $y = m x + c$  is tangent to the hyperbola

$$\frac{x^2}{a^2} - \frac{y^2}{b^2} = 1 \text{ if } c = \pm \sqrt{a^2 m^2 - b^2} \text{ and the point of contact is } \left(-\frac{a^2 m}{c}, \frac{-b^2}{c}\right).$$

The equation of tangent in terms slope is

$$y = m x \pm \sqrt{a^2 m^2 - b^2},$$

### 7.3.6 Tangents from a point to the hyperbola

Two tangents can be drawn to a hyperbola from any point outside the hyperbola in its plane.

Let P(x<sub>1</sub>, y<sub>1</sub>) be any point in plane of the hyperbola.

The equation of tangent to the hyperbola is

$$y = m x \pm \sqrt{a^2 m^2 - b^2}.$$

If the tangent passes through (x<sub>1</sub>, y<sub>1</sub>).

$$\therefore y_1 = m x_1 \pm \sqrt{a^2 m^2 - b^2}.$$

$$\therefore y_1 - m x_1 = \pm \sqrt{a^2 m^2 - b^2}.$$

Squaring on both sides and simplifying we get the quadratic equation in  $m$  which is found to be,

$$(x_1^2 - a^2)m^2 - 2x_1 y_1 m + (y_1^2 + b^2) = 0$$

it has two roots say, m<sub>1</sub> and m<sub>2</sub> which are the slopes of two tangents.

Thus, in general, two tangents can be drawn to a hyperbola from a given point in its plane.

$$\text{Sum of the roots} = m_1 + m_2 = \frac{-(-2x_1 y_1)}{(x_1^2 - a^2)}$$

$$= \frac{(2x_1 y_1)}{(x_1^2 - a^2)}$$

$$\text{Product of roots} = m_1 m_2 = \frac{(y_1^2 + b^2)}{(x_1^2 - a^2)}$$

### 7.3.7 Locus of point of intersection of perpendicular tangents :

If the tangent drawn from P are mutually perpendicular then we have  $m_1 m_2 = -1$

$$\therefore (y_1^2 + b^2) = -(x_1^2 - a^2)$$

$$\therefore x_1^2 + y_1^2 = a^2 - b^2$$

Which is the equation of standard circle with Centre at origin and radius  $\sqrt{a^2 - b^2}$  ( $a > b$ ). This is called the director circle of the hyperbola.

### 7.3.8 Auxiliary Circle, Director Circle

The director circle of the given hyperbola is the locus of a point, the tangents from which to the hyperbola are at right angles.

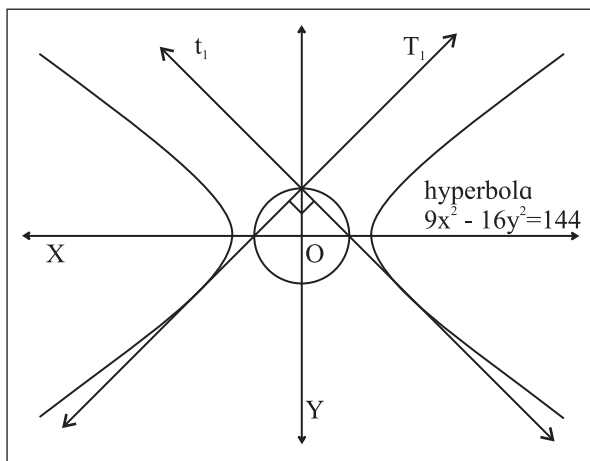

Fig. 7.29

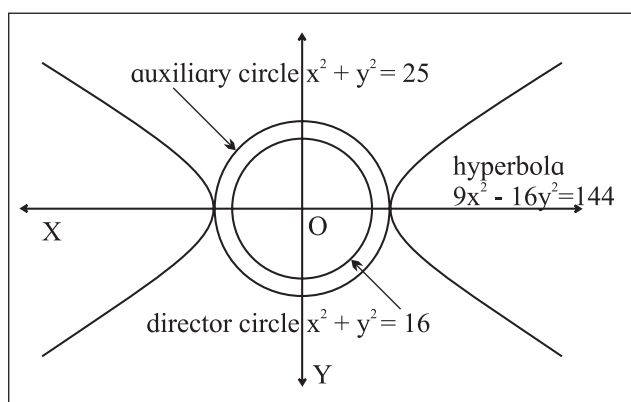

Fig. 7.30

For the standard hyperbola  $\frac{x^2}{a^2} - \frac{y^2}{b^2} = 1$ , the circle drawn with transverse axis as a diameter is called the auxiliary circle of the hyperbola and its equation is  $x^2 + y^2 = a^2$ .

The locus of point of intersection of perpendicular tangents to the hyperbola  $\frac{x^2}{a^2} - \frac{y^2}{b^2} = 1$  is called the director circle of the hyperbola and its equation is  $x^2 + y^2 = a^2 - b^2$ . ( $a > b$ ).

auxiliary circle  $x^2 + y^2 = 25$ ;  
 director circle  $x^2 + y^2 = 16$  of the  
 hyperbola  $9x^2 - 16y^2 = 144$ . (Refer fig 7.30)

### 7.3.9 Asymptote:

Consider the lines  $\frac{x}{a} = \pm \frac{y}{b}$ , they pass through origin O.

Consider the point P moving along the line so that distance OP goes on increasing, then the distance between P and hyperbola goes on decreasing but does not become zero. Here the distance between the point P and hyperbola is tending to zero, such a straight line is called an asymptote for the hyperbola

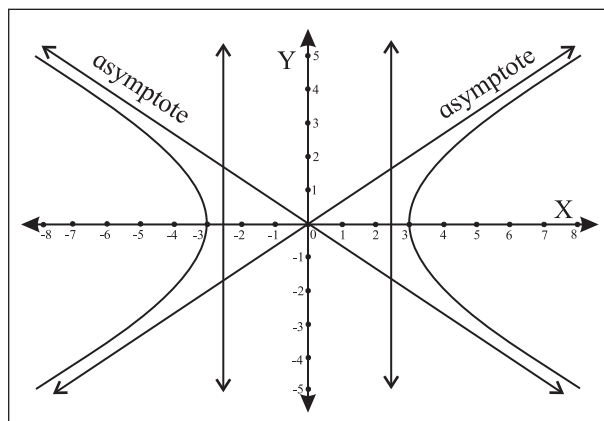

Fig. 7.31

### SOLVED EXAMPLES

**Ex.1 :** Find the equation of the tangent to the hyperbola  $2x^2 - 3y^2 = 5$  at a point in the third quadrant whose abscissa is  $-2$ .

**Solution :** Let  $P(-2, y_1)$  be the point on the hyperbola

$$\therefore 2(-2)^2 - 3y^2 = 5$$

$$\therefore 8 - 5 = 3y^2$$

$$\therefore 3 = 3y^2$$

$$\therefore y^2 = 1$$

$$\therefore y = \pm 1$$

But P lies in the third quadrant.

$$\therefore P \equiv (-2, -1)$$

The equation of the hyperbola is

$$\frac{x^2}{5/2} - \frac{y^2}{5/3} = 1. \text{ Comparing this with the}$$

equation  $\frac{x^2}{a^2} - \frac{y^2}{b^2} = 1$ , we have

$$a^2 = \frac{5}{2}, \quad b^2 = \frac{5}{3}$$

The equation of tangent at

$P(x_1, y_1) \equiv P(-2, -1)$  is

$$\frac{xx_1}{a^2} - \frac{yy_1}{b^2} = 1 \quad \therefore \left( 3 \times \frac{\sqrt{5}}{3}, \frac{(2)^2}{3} \right) = \left( \sqrt{5}, \frac{4}{3} \right)$$

$$\therefore 2xx_1 - 3yy_1 = 5$$

$$\therefore 2x(-2) - 3y(-1) = 5$$

$$\therefore -4x + 3y = 5$$

$$\therefore 4x - 3y + 5 = 0$$

**Ex. 2 :** Show that the line  $4x - 3y = 16$  touches the hyperbola  $16x^2 - 25y^2 = 400$ . Find the co-ordinates of the point of contact.

**Solution :** The equation of the hyperbola is

$$\frac{x^2}{25} - \frac{y^2}{16} = 1.$$

Comparing it with the equation  $\frac{x^2}{a^2} - \frac{y^2}{b^2} = 1$ .

we have  $a^2 = 25$ ,  $b^2 = 16$

The equation of the line is  $3y = 4x - 16$

$$\therefore y = \frac{4}{3}x - \frac{16}{3}$$

$\therefore$  Comparing it with the equation

$$y = mx + c$$

$$\text{We get } m = \frac{4}{3}, \quad c = \frac{-16}{3}$$

Now

$$a^2m^2 - b^2 = 25 \left( \frac{16}{9} \right) - 16$$

$$= \frac{256}{9} - \left( \frac{-16}{3} \right)^2 = c^2$$

Thus the condition of tangency is satisfied.

$\therefore$  the given line touches the hyperbola.

Let  $P(x_1, y_1)$  be the point of contact.

$$\therefore x_1 = \frac{-a^2m}{c} = \frac{-25 \left( \frac{4}{3} \right)}{\left( \frac{-16}{3} \right)} = \frac{25}{4}$$

$$\text{and } y_1 = \frac{-b^2}{c} = \frac{-16}{-16/3} = 3$$

$\therefore$  the point of contact is  $P \left( \frac{25}{4}, 3 \right)$

**Ex. 3 :** If the line  $2x + y + k = 0$  is tangent to the hyperbola  $\frac{x^2}{6} - \frac{y^2}{8} = 1$  then find the value of  $k$ .

**Solution :** The equation of the hyperbola is

$$\frac{x^2}{6} - \frac{y^2}{8} = 1.$$

The equation of the line is  $2x + y + k = 0$

$$\therefore y = -2x - k$$

Putting this value of  $y$  in the equation of hyperbola, we get

$$\frac{x^2}{6} - \frac{(-2x - k)^2}{8} = 1$$

$$\therefore 4x^2 - 3(4x^2 + 4kx + k^2) = 24$$

$$\therefore 4x^2 - 12(4x^2 - 12kx - 3k^2) = 24$$

$$\therefore 8x^2 + 12kx + (3k^2 + 24) = 0 \dots\dots\dots(1)$$

Since given line touches the hyperbola

$\therefore$  the quadratic equation (1) in  $x$  has equal roots.

$\therefore$  its discriminant = 0 i.e.  $b^2 - 4ac = 0$

$$\therefore (12k)^2 - 4(8)(3k^2 + 24) = 0$$

$$\therefore 144k^2 - 32(3k^2 + 24) = 0$$

$$\therefore 9k^2 - 2(3k^2 + 24) = 0$$

$$\therefore 9k^2 - 6k^2 - 48 = 0$$

$$\therefore 3k^2 = 48$$

$$\therefore k^2 = 16$$

$$\therefore k^2 = \pm 4$$

**Another Method :**

Here  $c = -k$ ,  $m = -2$ ,  $a^2 = b$ ,  $b^2 = 8$

$$\therefore c^2 = a^2m^2 - b^2$$

$$\therefore k^2 = [(-2)^2, 6] = 8$$

$$\therefore k^2 = 16$$

$$\therefore k = \pm 4$$

**Ex.4 :** The line  $x - y + 3 = 0$  touches the hyperbola whose foci are  $(\pm\sqrt{41}, 0)$ . Find the equation of the hyperbola.

**Solution :** Let the equation of the hyperbola be

$$\frac{x^2}{a^2} - \frac{y^2}{b^2} = 1 \dots\dots\dots(1)$$

Its foci  $(\pm ae, 0)$  are  $(\pm\sqrt{41}, 0)$

$$\therefore ae = \sqrt{41}$$

$$\therefore a^2 e^2 = 41$$

$$\therefore a^2 + b^2 = 41 \dots\dots\dots(2) \quad (a^2e^2 = a^2 + b^2)$$

The given line is  $y = x + 3$

Comparing this with  $y = mx + c$ , we get

$$m = 1, c = 3$$

Since the given line touches the hyperbola

$\therefore$  It satisfies the condition of tangency.

$$\therefore a^2m^2 - b^2 = c^2$$

$$\therefore a^2(1)^2 - b^2 = (3)^2$$

$$\therefore a^2 - b^2 = 9 \dots\dots\dots(3)$$

By adding (2) and (3), we get

$$2a^2 = 50 \quad \therefore a^2 = 25$$

from (2), we get

$$25 + b^2 = 41 \quad \therefore b^2 = 16$$

From (1), the equation of the required hyperbola is

$$\frac{x^2}{25} - \frac{y^2}{16} = 1$$

**EXERCISE 7.3**

1) Find the length of transverse axis, length of conjugate axis, the eccentricity, the co-ordinates of foci, equations of directrices and the length of latus rectum of the hyperbola.

i)  $\frac{x^2}{25} - \frac{y^2}{16} = 1$

ii)  $\frac{x^2}{25} - \frac{y^2}{16} = -1$

iii)  $16x^2 - 9y^2 = 144$

iv)  $21x^2 - 4y^2 = 84$

v)  $3x^2 - y^2 = 4$

vi)  $x^2 - y^2 = 16$

vii)  $\frac{y^2}{25} - \frac{x^2}{9} = 1$

viii)  $\frac{y^2}{25} - \frac{x^2}{144} = 1$

ix)  $\frac{x^2}{100} - \frac{y^2}{25} = +1$

(x)  $x = 2 \sec \theta, y = 2\sqrt{3} \tan \theta$

2) Find the equation of the hyperbola with centre at the origin, length of conjugate axis 10 and one of the foci  $(-7, 0)$ .

3) Find the eccentricity of the hyperbola, which is conjugate to the hyperbola  $x^2 - 3y^2 = 3$ .

4) If  $e$  and  $e'$  are the eccentricities of a hyperbola and its conjugate hyperbola respectively, prove that  $\frac{1}{e^2} + \frac{1}{(e')^2} = 1$

5) Find the equation of the hyperbola referred to its principal axes.

i) whose distance between foci is 10 and eccentricity  $\frac{5}{2}$ .

ii) whose distance between foci is 10 and length of conjugate axis 6.

iii) whose distance between directrices is  $\frac{8}{3}$  and eccentricity is  $\frac{3}{2}$ .

- iv) whose length of conjugate axis = 12 and passing through  $(1, -2)$ .
- v) which passes through the points  $(6, 9)$  and  $(3, 0)$ .
- vi) whose vertices are  $(\pm 7, 0)$  and end points of conjugate axis are  $(0, \pm 3)$ .
- vii) whose foci are at  $(\pm 2, 0)$  and eccentricity  $\frac{3}{2}$ .
- viii) whose length of transverse and conjugate axis are 6 and 9 respectively.
- ix) whose length of transverse axis is 8 and distance between foci is 10.
- 6) Find the equation of the tangent to the hyperbola.
- i)  $3x^2 - y^2 = 4$  at the point  $(2, 2\sqrt{2})$ .
- ii)  $3x^2 - y^2 = 12$  at the point  $(4, 3)$ .
- iii)  $\frac{x^2}{144} - \frac{y^2}{25} = 1$  at the point whose eccentric angle is  $\frac{\pi}{3}$ .
- iv)  $\frac{x^2}{16} - \frac{y^2}{9} = 1$  at the point in a first quadratures whose ordinate is 3.
- v)  $9x^2 - 16y^2 = 144$  at the point L of latus rectum in the first quadrant.
- 7) Show that the line  $3x - 4y + 10 = 0$  is tangent to the hyperbola  $x^2 - 4y^2 = 20$ . Also find the point of contact.
- 8) If the  $3x - 4y = k$  touches the hyperbola  $\frac{x^2}{5} - \frac{4y^2}{5} = 1$  then find the value of  $k$ .
- 9) Find the equations of the tangents to the hyperbola  $\frac{x^2}{25} - \frac{y^2}{9} = 1$  making equal intercepts on the co-ordinate axes.
- 10) Find the equations of the tangents to the hyperbola  $5x^2 - 4y^2 = 20$  which are parallel to the line  $3x + 2y + 12 = 0$ .

Conic section	Eccentricity	Equation of the curve $(x, f(x))$	Equation of tangent at point $(x_1, y_1)$ on it	Point of contact of the target	Condition for tangency
circle	-	$x^2 + y^2 = a^2$	$xx_1 + yy_1 = a^2$	-	$c^2 = a^2m^2 + a^2$
parabola	$e=1$	$y^2 = 4ax$	$yy_1 = 2a(x_1 - y_1)$	$\left(\frac{a}{m^2}, \frac{2a}{m}\right)$	$c = \left(\frac{a}{m}\right)$
ellipse	$0 < e < 1$	$\frac{x^2}{a^2} + \frac{y^2}{b^2} = 1$ $(a > b)$	$\frac{xx_1}{a^2} + \frac{yy_1}{b^2} = 1$	$\left(\frac{-a^2m}{c}, \frac{+b^2}{c}\right)$	$c^2 = a^2m^2 + b^2$
hyperbola	$e > 1$	$\frac{x^2}{a^2} - \frac{y^2}{b^2} = 1$	$\frac{xx_1}{a^2} - \frac{yy_1}{b^2} = 1$	$\left(\frac{-a^2m}{c}, \frac{-b^2}{c}\right)$	$c^2 = a^2m^2 - b^2$

Curve	Equation of auxillary circle	Equation of director circle
$x^2 + y^2 = a^2$ (circle)	--	$x^2 + y^2 = a^2 + a^2$
$\frac{x^2}{a^2} + \frac{y^2}{b^2} = 1$ ( $a > b$ )	$x^2 + y^2 = a^2$	$x^2 + y^2 = a^2 + b^2$
$\frac{x^2}{a^2} - \frac{y^2}{b^2} = 1$ ( $a > b$ )	$x^2 + y^2 = a^2$	$x^2 + y^2 = a^2 - b^2$



**Let's Remember**

- A conic section or a conic can be defined as the locus of the point P in a plane such that the ratio of the distance of P, from a fixed point to its distance from a fixed line is constant.

The constant ratio is called the eccentricity of the conic section, denoted by 'e'.

- If  $e = 1$  the conic section is called parabola if  $0 < e < 1$  the conic section is called ellipse. if  $e > 1$  the conic section is called hyperbola.

- eccentricity of rectangular hyperbola is  $\sqrt{2}$ .
- standard equations of curve.

parabola  $y^2 = 4ax$ ,  $x^2 = 4by$

ellipse  $\frac{x^2}{a^2} + \frac{y^2}{b^2} = 1$ , ( $a > b$ )  $\frac{x^2}{a^2} + \frac{y^2}{b^2} = 1$  ( $b > a$ )

hyperbola  $\frac{x^2}{a^2} - \frac{y^2}{b^2} = 1$   $a > b$ ,

$\frac{y^2}{b^2} - \frac{x^2}{a^2} = 1$   $b > a$

- focal distance of a point P on the parabola  $y^2 = 4ax$  is a abscissa of point P.
- sum of focal distances of point on the ellipse is the length of major axis.
- Difference between the focal distances of point on the hyperbola is the length of transverse axis.

**MISCELLANEOUS EXERCISE - 7**

**(I) Select the correct option from the given alternatives.**

- 1) The line  $y = mx + 1$  is tangent to the parabola  $y^2 = 4x$  if m is .....
- A) 1      B) 2      C) 3      D) 4

- 2) The length of latus rectum of the parabola  $x^2 - 4x - 8y + 12 = 0$  is.....
- A) 4      B) 6      C) 8      D) 10
- 3) If the focus of the parabola is  $(0, -3)$  its directrix is  $y = 3$  then its equation is
- A)  $x^2 = -12y$       B)  $x^2 = 12y$   
 C)  $y^2 = 12x$       D)  $y^2 = -12x$
- 4) The coordinates of a point on the parabola  $y^2 = 8x$  whose focal distance is 4 are .....
- A)  $(1/2, \pm 2)$       B)  $(1, \pm 2\sqrt{2})$   
 C)  $(2, \pm 4)$       D) none of these
- 5) The end points of latus rectum of the parabola  $y^2 = 24x$  are.....
- A)  $(6, \pm 12)$       B)  $(12, \pm 6)$   
 C)  $(6, \pm 6)$       D) none of these
- 6) Equation of the parabola with vertex at the origin and directrix  $x + 8 = 0$  is.....
- A)  $y^2 = 8x$       B)  $y^2 = 32x$   
 C)  $y^2 = 16x$       D)  $x^2 = 32y$
- 7) The area of the triangle formed by the line joining the vertex of the parabola  $x^2 = 12y$  to the end points of its latus rectum is.....
- A) 22 sq.units      B) 20 sq.units  
 C) 18 sq.units      D) 14 sq.units
- 8) If  $P\left(\frac{\pi}{4}\right)$  is any point on the ellipse  $9x^2 + 25y^2 = 225$ . S and S' are its foci then  $SP \cdot S'P =$
- A) 13      B) 14      C) 17      D) 19
- 9) The equation of the parabola having  $(2, 4)$  and  $(2, -4)$  as end points of its latus rectum is.....
- A)  $y^2 = 4x$       B)  $y^2 = 8x$   
 C)  $y^2 = -16x$       D)  $x^2 = 8y$



- 11) The slopes of the tangents drawn from P to the parabola  $y^2 = 4ax$  are  $m_1$  and  $m_2$ , show that (i)  $m_1 - m_2 = k$  (ii)  $(m_1/m_2) = k$ , where k is a constant.
- 12) The tangent at point P on the parabola  $y^2 = 4ax$  meets the  $y$  - axis in Q. If S is the focus, show that SP subtends a right angle at Q.
- 13) Find the (i) lengths of the principal axes (ii) co-ordinates of the foci (iii) equations of directrices (iv) length of the latus rectum (v) Distance between foci (vi) distance between directrices of the curve (a)  $x^2/25 + y^2/9 = 1$  (b)  $16x^2 + 25y^2 = 400$  (c)  $x^2/144 - y^2/25 = 1$  (d)  $x^2 - y^2 = 16$
- 14) Find the equation of the ellipse in standard form if (i) eccentricity =  $3/8$  and distance between its foci=6. (ii) the length of major axis 10 and the distance between foci is 8. (iii) passing through the points  $(-3, 1)$  and  $(2, -2)$ .
- 15) Find the eccentricity of an ellipse if the distance between its directrices is three times the distance between its foci.
- 16) For the hyperbola  $x^2/100 - y^2/25 = 1$ , prove that SA. S'A = 25, where S and S' are the foci and A is the vertex.
- 17) Find the equation of the tangent to the ellipse  $x^2/5 - y^2/4 = 1$  passing through the point  $(2, -2)$ .
- 18) Find the equation of the tangent to the ellipse  $x^2 + 4y^2 = 100$  at  $(8, 3)$ .
- 19) Show that the line  $8y + x = 17$  touches the ellipse  $x^2 + 4y^2 = 17$ . Find the point of contact.
- 20) Tangents are drawn through a point P to the ellipse  $4x^2 + 5y^2 = 20$  having inclinations  $\theta_1$  and  $\theta_2$  such that  $\tan \theta_1 + \tan \theta_2 = 2$ . Find the equation of the locus of P.
- 21) Show that the product of the lengths of its perpendicular segments drawn from the foci to any tangent line to the ellipse  $x^2/25 + y^2/16 = 1$  is equal to 16.
- 22) Find the equation of the hyperbola in the standard form if (i) Length of conjugate axis is 5 and distance between foci is 13. (ii) eccentricity is  $3/2$  and distance between foci is 12. (iii) length of the conjugate axis is 3 and distance between the foci is 5.
- 23) Find the equation of the tangent to the hyperbola, (i)  $7x^2 - 3y^2 = 51$  at  $(-3, -2)$  (ii)  $x = 3 \sec\theta, y = 5 \tan\theta$  at  $\theta = \pi/3$  (iii)  $x^2/25 - y^2/16 = 1$  at  $P(30^\circ)$ .
- 24) Show that the line  $2x - y = 4$  touches the hyperbola  $4x^2 - 3y^2 = 24$ . Find the point of contact.
- 25) Find the equations of the tangents to the hyperbola  $3x^2 - y^2 = 48$  which are perpendicular to the line  $x + 2y - 7 = 0$
- 26) Two tangents to the hyperbola  $\frac{x^2}{a^2} - \frac{y^2}{b^2} = 1$  make angles  $\theta_1, \theta_2$ , with the transverse axis. Find the locus of their point of intersection if  $\tan\theta_1 + \tan\theta_2 = k$ .



# 8 Measures of Dispersion



## Let's Study

- Meaning and Definition of Dispersion
- Range of data.
- Variance and Standard Deviation
- Coefficient of Variation



## Let's Recall

- Concept of Constant and Variable
- Concept of an Average
- Computation of Mean for Ungrouped and Grouped Data

*“An average does not tell the full story. It is hardly fully representative of a mass unless we know the manner in which the individual items scatter around it. A further description of the series is necessary if we are to gauge how representative the average is.”*

- George Simpson and Fritz Kafka

## Let's Observe

In the earlier classes we have learnt about the measures of central tendency mean, median and mode. Such an average tells us only about the central part of the data. But it does not give any information about the spread of the data. For example, consider the runs scored by 3 batsmen in a series of 5 One Day International matches.

Batsman	Runs scored	Total	Mean
X	90, 17, 104, 33, 6	250	50
Y	40, 60, 55, 50, 45	250	50
Z	112, 8, 96, 29, 5	250	50

All the above series have the same size ( $n=5$ ) and the same mean (50), but they are different in composition. Thus, to decide who is more dependable, the measure of mean is not sufficient. The spread of data or variation is a factor which needs our attention. To understand more about this we need some other measure. One such measure is Dispersion.

In the above example, observations from series X and series Z are more scattered as compared to those in series Y. So Y is more consistent. The extent of scatter in observations which deviate from mean is called dispersion.

## Activity :

Given two different series-

A : 0.5, 1, 1.5, 3, 4, 8

B : 2, 2.2, 2.6, 3.4, 3.8,

Find arithmetic means of the two series.

Plot the two series on the number line.

Observe the scatter of the data in each series and decide which series is more scattered.



## Let's Learn

## According to Spiegel:

“The degree to which numerical data tend to spread about an average value is called the **variation** or **dispersion** of the data.”

## 8.1 Measures of Dispersion :

Following measures of dispersion are the commonly used –

- Range
- Variance
- Standard deviation

### 8.1.1 Range :

Range is the simplest measure of dispersion. It is defined as the difference between the largest value and the smallest value in the data.

Thus, **Range = Largest Value – Smallest Value = L – S**

Where, L = Largest Value and S = Smallest Value.

#### Uses of Range:

- 1) It is used in stock market.
- 2) It is used in calculations of mean temperature of a certain place.

### SOLVED EXAMPLES

**Ex.1)** Following data gives weights of 10 students (in kgs) in a certain school. Find the range of the data.

70, 62, 38, 55, 43, 73, 36, 58, 65, 47

**Solution :** Smallest Value = S = 36

Largest Value = L = 73

Range = L – S = 73 – 36 = 37

**Ex.2.** Calculate range for the following data.

Salary (00's Rs.)	30-50	50-70	70-90	90-110	110-130	130-150
No. of Employees	7	15	30	24	18	11

**Solution :**

L = Upper limit of highest class = 150

S = Lower limit of lowest class = 30

∴ Range = L – S = 150 – 30 = 120

### EXERCISE 8.1

1. Find range of the following data:  
19, 27, 15, 21, 33, 45, 7, 12, 20, 26

2. Find range of the following data:  
575, 609, 335, 280, 729, 544, 852, 427, 967, 250

3. The following data gives number of typing mistakes done by Radha during a week. Find the range of the data.

Day	Mon-day	Tues-day	Wed-nesday	Thurs-day	Fri-day	Satur-day
No. of mis-takes	15	20	21	12	17	10

4. Following results were obtained by rolling a die 25 times. Find the range of the data.

Score	1	2	3	4	5	6
Frequency	4	6	2	7	3	3

5. Find range for the following data.

Classes	62-64	64-66	66-68	68-70	70-72
Frequency	5	3	4	5	3



### Let's Learn

## 8.2 VARIANCE and STANDARD DEVIATION:

The main drawback of the range is that it is based on only two values, and does not consider all the observations. The variance and standard deviation overcome this drawback as they are based on the deviations taken from the mean.

### 8.2.1 Variance:

The variance of a variable X is defined as the arithmetic mean of the squares of all deviations of X taken from its arithmetic mean.

It is denoted by Var(X) or  $\sigma^2$ .

$$\text{Var}(X) = \sigma^2 = \frac{1}{n} \sum_{i=1}^n (x_i - \bar{x})^2$$

#### Note :

We have,

$$\text{Var}(X) = \frac{1}{n} \sum_{i=1}^n (x_i - \bar{x})^2$$

$$\begin{aligned}
 &= \frac{1}{n} \sum_{i=1}^n (x_i^2 - 2x_i \bar{x} + \bar{x}^2) \\
 &= \frac{1}{n} \sum_{i=1}^n x_i^2 - 2\bar{x} \cdot \frac{1}{n} \sum_{i=1}^n x_i + \bar{x}^2 \frac{1}{n} \sum_{i=1}^n 1 \\
 &= \frac{1}{n} \sum_{i=1}^n x_i^2 - 2\bar{x} \cdot \bar{x} + \bar{x}^2 \times \frac{1}{n} n \\
 &= \frac{1}{n} \sum_{i=1}^n x_i^2 - 2\bar{x}^2 + \bar{x}^2 \\
 &= \frac{1}{n} \sum_{i=1}^n x_i^2 - \bar{x}^2
 \end{aligned}$$

Therefore,  $\text{Var}(X) = \sigma^2 = \frac{1}{n} \sum_{i=1}^n (x_i - \bar{x})^2$

$$= \frac{1}{n} \sum_{i=1}^n x_i^2 - \bar{x}^2$$

### 8.2.2 Standard Deviation :

Standard Deviation is defined as the positive square root of the variance.

It is denoted by  $\sigma$  (sigma) and  $\sigma = \sqrt{\text{Var}(X)}$

#### (i) Variance and Standard Deviation for raw data :

Let the variable X takes the values  $x_1, x_2, x_3, \dots, x_n$ . Let  $\bar{x}$  be the arithmetic mean.

Then,

$$\begin{aligned}
 \text{Var}(X) = \sigma^2 &= \frac{1}{n} \sum_{i=1}^n (x_i - \bar{x})^2 \\
 &= \frac{\sum_{i=1}^n x_i^2}{n} - \bar{x}^2
 \end{aligned}$$

Where,  $\bar{x} = \frac{\sum_{i=1}^n x_i}{n}$  S. D. =  $\sigma = \sqrt{\text{Var}(X)}$

#### (ii) Variance and Standard Deviation for ungrouped frequency distribution :

Let  $x_1, x_2, \dots, x_n$  be the values of variable X with corresponding frequencies  $f_1, f_2, \dots, f_n$  respectively, then the variance of X is defined as

$$\begin{aligned}
 \text{Var}(X) = \sigma^2 &= \frac{1}{n} \sum_{i=1}^n f_i (x_i - \bar{x})^2 \\
 &= \frac{\sum_{i=1}^n f_i x_i^2}{N} - \bar{x}^2,
 \end{aligned}$$

Where,  $\bar{x} = \frac{\sum_{i=1}^n f_i x_i}{N}$ , and  $\sum f_i = N = \text{Total frequency}$  S. D. =  $\sigma = \sqrt{\text{Var}(X)}$

#### (iii) Variance and Standard Deviation for grouped frequency distribution :

Let  $x_1, x_2, \dots, x_n$  be the mid points of the intervals. and  $f_1, f_2, \dots, f_n$  are corresponding class frequencies, then the variance is defined as :

$$\begin{aligned}
 \text{Var}(X) = \sigma^2 &= \frac{1}{n} \sum_{i=1}^n f_i (x_i - \bar{x})^2 \\
 &= \frac{\sum_{i=1}^n f_i x_i^2}{N} - \bar{x}^2,
 \end{aligned}$$

Where,

$$\bar{x} = \frac{\sum_{i=1}^n f_i x_i}{N}, \text{ and } \sum_{i=1}^n f_i = N = \text{Total frequency}$$

S. D. =  $\sigma = \sqrt{\text{Var}(X)}$

### 8.2.3 Change of origin and scale:

1. The variance and consequently the standard deviation are independent of change of origin.

That is if  $d = x - A$  where  $A$  the class mark of middle class interval if the number of classes is odd. If the number of classes is even, then there will be two middle class intervals and  $A$  is the class mark of the one having greater frequency.

then  $\sigma_d^2 = \sigma_x^2$  and  $\sigma_d = \sigma_x$

It means that if  $\sigma_x$  is standard deviation of the values  $x_1, x_2, x_3, \dots, x_n$ . The standard deviation  $\sigma_d$ , of  $x_1 - A, x_2 - A, x_3 - A, \dots, x_n - A$  is also same as that of  $\sigma_x$ .

2. The variance and consequently the standard deviation are not independent of change of scale.

Let  $u = \frac{x-A}{h}$  where  $h$  is width of the class

interval if given. If the class intervals are not given, then  $h$  is the difference (or distance) between the two consecutive value of  $x_i$ .

and  $h \neq 0$ , then  $\sigma_x = h \sigma_u$

and  $\sigma_x^2 = h^2 \sigma_u^2$

It means that if  $\sigma_x$  is standard deviation of the values  $x_1, x_2, \dots, x_n$ . Then standard deviation

$\sigma_u$  of  $\frac{x_1-A}{h}, \frac{x_2-A}{h}, \frac{x_3-A}{h}, \dots, \frac{x_n-A}{h}$  is  $\frac{1}{h}$  times of  $\sigma_x$ .

### SOLVED EXAMPLES

**Ex.1)** Compute variance and standard deviation of the following data observations.

9, 12, 15, 18, 21, 24, 27

**Solution :**

$x_i$	$x_i - \bar{x}$	$(x_i - \bar{x})^2$
9	-9	81
12	-6	36
15	-3	9
18	0	0
21	3	9
24	6	36
27	9	81
<b>126</b>		<b>252</b>

Here,  $n = 7$ ,  $\bar{x} = \frac{\sum x_i}{n} = \frac{126}{7} = 18$

$$\text{Var}(X) = \sigma^2 = \frac{1}{n} \sum (x_i - \bar{x})^2 = \frac{252}{7} = 36$$

$$\text{S.D.} = \sigma = \sqrt{\text{Var}(X)} = \sqrt{36} = 6$$

**Ex.2)** Given below are the marks out of 25 of 5 students in mathematics test. Calculate the variance and standard deviation of these observations.

Marks : 10, 13, 17, 20, 23

**Solution :** We use alternate method to solve this problem.

Calculation of variance :

$x_i$	$x_i^2$
10	100
13	169
17	289
20	400
23	529
<b>83</b>	<b>1487</b>

Here,  $n = 5$  and  $\bar{x} = \frac{\sum_{i=1}^n x_i}{n} = \frac{83}{5} = 16.6$

$$\begin{aligned} \text{Therefore, Var}(X) &= \sigma^2 = \frac{\sum_{i=1}^n x_i^2}{n} - (\bar{x})^2 \\ &= \frac{1487}{5} - (16.6)^2 \\ &= 297.4 - 275.56 \\ &= 21.84 \\ \text{S.D.} = \sigma &= \sqrt{\text{Var}(X)} = \sqrt{21.84} \\ &= 4.67 \end{aligned}$$

**Ex.3)** A die is rolled 30 times and the following distribution is obtained. Find the variance and S.D.

Score (X)	1	2	3	4	5	6
Frequency (f)	2	6	2	5	10	5

**Solution :**

X	f	f.x	f.x <sup>2</sup>
1	2	2	2
2	6	12	24

3	2	6	18
4	5	20	80
5	10	50	250
6	5	30	180
<b>Total</b>	<b>30</b>	<b>120</b>	<b>554</b>

We get,  $\bar{x} = \frac{\sum fx}{N} = \frac{120}{30} = 4$

Now,  $\sigma_x^2 = \frac{\sum fx^2}{N} - \bar{x}^2$   
 $= \frac{554}{30} - 4^2 = 18.47 - 16 = 2.47$

Therefore,  $\sigma_x = \sqrt{2.47} = 1.57$

**Ex. 4)** Compute variance and standard deviation for the following data:

<i>x</i>	15	20	25	30	35	40	45
<i>f</i>	13	12	15	18	17	10	15

**Solution:**

Let  $u = \frac{x-30}{5}$

<b>X</b>	<b>u</b>	<b>f</b>	<b>f.u</b>	<b>f.u<sup>2</sup></b>
15	-3	13	-39	117
20	-2	12	-24	48
25	-1	15	-15	15
30	0	18	0	0
35	1	17	17	17
40	2	10	20	40
45	3	15	45	135
<b>Total</b>		<b>100</b>	<b>4</b>	<b>372</b>

We get,  $\bar{u} = \frac{\sum f.u}{N} = \frac{4}{100} = 0.04$

Now,  $\sigma_u^2 = \frac{\sum f.u^2}{N} - \bar{u}^2$   
 $= \frac{372}{100} - 0.04^2$

$= 3.72 - 0.0016$

$= 3.7184$

Therefore,  $\sigma_u = \sqrt{3.7184} = 1.92$

$\sigma_x = h \sigma_u$

$= 5(1.92)$

$\therefore \sigma_x = 9.6$

**Ex.5.** Compute variance and standard deviation for the following data.

C.I.	45-55	55-65	65-75	75-85	85-95	95-105	105-115	115-125
<i>f</i>	7	20	27	23	13	6	3	1

**Solution :**

Let  $u = \frac{X-90}{10}$ .

Calculation of variance of u :

<b>Class-intervals</b>	<b>Mid value (x<sub>i</sub>)</b>	<b>f<sub>i</sub></b>	<b>u<sub>i</sub></b>	<b>f<sub>i</sub>u<sub>i</sub></b>	<b>f<sub>i</sub>u<sub>i</sub><sup>2</sup></b>
45-55	50	7	-4	-28	112
55-65	60	20	-3	-60	180
65-75	70	27	-2	-54	108
75-85	80	23	-1	-23	23
85-95	90	13	0	0	0
95-105	100	6	1	6	6
105-115	110	3	2	6	12
115-125	120	1	3	3	9
<b>Total</b>		<b>100</b>		<b>-150</b>	<b>450</b>

Now,  $\bar{u} = \frac{\sum f_i u_i}{N} = \frac{-150}{100} = -1.5$

$Var(u) = \sigma_u^2 = \frac{\sum f_i u_i^2}{N} - \bar{u}^2$

$Var(u) = \frac{450}{100} - (-1.5)^2 = 4.5 - 2.25$

$= 2.25$

Thus,  $Var(u) = 2.25$

$\therefore Var(X) = h^2 \cdot Var(u) = 10^2 \times 2.25 = 225$

$\therefore S.D. = \sigma_x = \sqrt{Var(X)} = \sqrt{225} = 15$

**Ex.6)** Find the standard deviation of the following frequency distribution which gives distribution of heights of 500 plants in centimeters.

Height of plants (in cm)	20-25	25-30	30-35	35-40	40-45	45-50
No. of plants	145	125	90	40	45	55

**Solution :** Let  $u = \frac{X - 32.5}{5}$ .

Calculation of variance of  $u$  :

Class	Mid value ( $x_i$ )	$f_i$	$u_i$	$f_i u_i$	$f_i u_i^2$
20-25	22.5	145	-2	-290	580
25-30	27.5	125	-1	-125	125
30-35	32.5	90	0	0	0
35-40	37.5	40	1	40	40
40-45	42.5	45	2	90	180
45-50	47.5	55	3	165	495
<b>Total</b>				<b>-120</b>	<b>1420</b>

$$\text{Now, } \bar{u} = \frac{\sum f_i u_i}{N} = \frac{-120}{500} = -0.24$$

$$\begin{aligned} \text{Var}(u) &= \sigma_u^2 = \frac{\sum f_i u_i^2}{N} - \bar{u}^2 \\ &= \frac{1420}{500} - (-0.24)^2 \\ &= 2.84 - 0.0576 = 2.7824 \end{aligned}$$

Thus,  $\text{Var}(u) = 2.7824$

$$\therefore \text{Var}(X) = h^2 \cdot \text{Var}(u) = 5^2 \times 2.7824 = 69.56 \text{ cm}^2$$

$$\therefore \text{S.D.} = \sigma_x = \sqrt{\text{Var}(X)} = \sqrt{69.56} = 8.34 \text{ cm}$$

### EXERCISE 8.2

Q. Find variance and S.D. for the following set of numbers.

- 7, 11, 2, 4, 9, 6, 3, 7, 11, 2, 5, 8, 3, 6, 8, 8, 2, 6
- 65, 77, 81, 98, 100, 80, 129

3. Compute variance and standard deviation for the following data:

X	2	4	6	8	10	12	14	16	18	20
F	8	10	10	7	6	4	3	4	2	6

4. Compute the variance and S.D.

X	31	32	33	34	35	36	37
Frequency	15	12	10	8	9	10	6

5. Following data gives age of 100 students in a college. Calculate variance and S.D.

Age (In years)	16	17	18	19	20	21
No. of Students	20	7	11	17	30	15

6. Find mean, variance and S.D. of the following data.

Classes	10-20	20-30	30-40	40-50	50-60	60-70	70-80	80-90	90-100
Freq.	7	14	6	13	9	15	11	10	15

7. Find the variance and S.D. of the following frequency distribution which gives the distribution of 200 plants according to their height.

Height (in cm)	14-18	19-23	24-28	29-33	34-38	39-43	44-48
No. of plants	5	18	44	70	36	22	5

8. The mean of 5 observations is 4.8 and the variance is 6.56. If three of the five observations are 1, 3 and 8, find the other two observations.



### Let's :Learn

### 8.3 Standard Deviation for Combined data :

If  $\sigma_1, \sigma_2$  are standard deviations and  $\bar{x}_1, \bar{x}_2$  are the arithmetic means of two data sets of sizes  $n_1$  and  $n_2$  respectively, then the mean for the combined data is :

$$\bar{x}_c = \frac{n_1 \bar{x}_1 + n_2 \bar{x}_2}{n_1 + n_2}$$

And the Standard Deviation for the combined series is :

$$\sigma_c = \sqrt{\frac{n_1(\sigma_1^2 + d_1^2) + n_2(\sigma_2^2 + d_2^2)}{n_1 + n_2}}$$

Where,  $d_1 = \bar{x}_1 - \bar{x}_c$  and  $d_2 = \bar{x}_2 - \bar{x}_c$

### SOLVED EXAMPLES

**Ex.1)** The means of two samples of sizes 10 and 20 are 24 and 45 respectively and the standard deviations are 6 and 11. Obtain the standard deviation of the sample of size 30 obtained by combining the two samples.

**Solution :**

Let  $n_1 = 10$ ,  $n_2 = 20$ ,  $\bar{x}_1 = 24$ ,  $\bar{x}_2 = 45$ ,  $\sigma_1 = 6$ ,  $\sigma_2 = 11$

Combined mean is :

$$\begin{aligned}\bar{x}_c &= \frac{n_1\bar{x}_1 + n_2\bar{x}_2}{n_1 + n_2} = \frac{10 \times 24 + 20 \times 45}{10 + 20} \\ &= \frac{1140}{30} = 38\end{aligned}$$

Combined standard deviation is given by,

$$\sigma_c = \sqrt{\frac{n_1(\sigma_1^2 + d_1^2) + n_2(\sigma_2^2 + d_2^2)}{n_1 + n_2}}$$

Where,  $d_1 = \bar{x}_1 - \bar{x}_c$  and  $d_2 = \bar{x}_2 - \bar{x}_c$

$\therefore d_1 = \bar{x}_1 - \bar{x}_c = 24 - 38 = -14$  and

$d_2 = \bar{x}_2 - \bar{x}_c = 45 - 38 = 7$

$$\begin{aligned}\sigma_c &= \sqrt{\frac{10(6^2 + (-14)^2) + 20(11^2 + 7^2)}{10 + 20}} \\ &= \sqrt{\frac{2320 + 3400}{30}} = \sqrt{\frac{5720}{30}} \\ &= \sqrt{190.67} = 13.4\end{aligned}$$

**Ex.2)** The first group has 100 items with mean 45 and variance 49. If the combined group has 250 items with mean 51 and variance 130, find the mean and standard deviation of second group.

**Solution :**

Given,  $n_1 = 100$ ,  $\bar{x}_1 = 45$ ,  $\sigma_1^2 = 49$

For combined group,  $n = 250$ ,  $\bar{x}_c = 51$ ,  $\sigma_c^2 = 130$ ,

To find :  $\bar{x}_2$  and  $\sigma_c$

$$n = n_1 + n_2 \Rightarrow 250 = 100 + n_2 \Rightarrow n_2 = 150$$

$$\text{We have, } \bar{x}_c = \frac{n_1\bar{x}_1 + n_2\bar{x}_2}{n_1 + n_2}$$

$$51 = \frac{100 \times 45 + n_2\bar{x}_2}{100 + 150}$$

$$12750 = 4500 + 150 \bar{x}_2$$

Therefore,  $\bar{x}_2 = 55$

Combined standard deviation is given by,

$$\sigma_c^2 = \frac{n_1(\sigma_1^2 + d_1^2) + n_2(\sigma_2^2 + d_2^2)}{n_1 + n_2}$$

Where,  $d_1 = \bar{x}_1 - \bar{x}_c = 45 - 51 = -6$

and  $d_2 = \bar{x}_2 - \bar{x}_c = 55 - 51 = 4$

$$130 = \frac{100(49 + 36) + 150(\sigma_2^2 + 16)}{100 + 150}$$

$$32500 = 150\sigma_2^2 + 10900$$

$$\sigma_2^2 = 144$$

Therefore,  $\sigma_2 = \sqrt{144} = 12$

$\therefore$  S.D. of second group = 12



### Let's :Learn

#### 8.3.1 Coefficient of Variation :

Standard deviation depends upon the unit of measurement. Therefore it cannot be used to compare two or more series expressed in different units. For this purpose coefficient of variation (C.V.) is used and is defined as,

$$\text{C. V.} = 100 \times \frac{\sigma}{\bar{x}}$$

Coefficient of Variation is used to compare the variability of two distributions. A distribution with smaller C.V. is said to be more homogenous or compact and the series with larger C.V. is said to be more heterogeneous. The distribution with smaller C.V. is said to be more consistent.

**SOLVED EXAMPLES**

**Ex.1)** The arithmetic mean of runs scored by 3 batsmen Varad, Viraj and Akhilesh in the same series are 50, 52 and 21 respectively. The standard deviation of their runs are 11, 16 and 5 respectively. Who is the most consistent of the three? If one of the three is to be selected, who will be selected?

**Solution :**

Let  $\bar{x}_1, \bar{x}_2, \bar{x}_3$  and  $\sigma_1, \sigma_2, \sigma_3$  be the means and standard deviations of the three batsmen Varad, Viraj and Akhilesh respectively.

Therefore,  $\bar{x}_1 = 50, \bar{x}_2 = 52, \bar{x}_3 = 21$  and  $\sigma_1 = 11, \sigma_2 = 16, \sigma_3 = 5$

$$\begin{aligned} \text{Now, C. V. of runs scored by Varad} &= 100 \times \frac{\sigma_1}{\bar{x}_1} \\ &= 100 \times \frac{11}{50} = 22 \end{aligned}$$

$$\begin{aligned} \text{C. V. of runs scored by Viraj} &= 100 \times \frac{\sigma_2}{\bar{x}_2} \\ &= 100 \times \frac{16}{52} = 30.76 \end{aligned}$$

$$\begin{aligned} \text{C. V. of runs scored by Akhilesh} &= 100 \times \frac{\sigma_3}{\bar{x}_3} \\ &= 100 \times \frac{5}{21} = 23.81 \end{aligned}$$

- (i) Since the C. V. of the runs is smaller for Varad, he is the most consistent player.
- (ii) To take decision regarding the selection, let us consider both the C.V.s and means.

**(a) Based on consistency :**

Since C.V. of Varad is smallest, he is more consistent and hence is to be selected.

**(b) Based on expected score :**

If the player with highest expected score (mean) is to be selected, then Viraj will be selected.

**Ex.2.** The following values are calculated in respect of prices of shares of companies X and Y. State the share of which company is more stable in value.

	Share of X	Share of Y
Mean	50	105
Variance	7	4

**Solution :**

Here,  $\sigma_x^2 = 7, \sigma_y^2 = 4, \bar{x} = 50, \bar{y} = 105$

Therefore  $\sigma_x = \sqrt{7} = 2.64, \sigma_y = \sqrt{4} = 2$

$$\text{C.V.}(X) = 100 \times \frac{\sigma_x}{\bar{x}} = 100 \times \frac{2.64}{50} = 5.28$$

$$\text{C.V.}(Y) = 100 \times \frac{\sigma_y}{\bar{y}} = 100 \times \frac{2}{105} = 1.90$$

Since  $\text{C.V.}(Y) < \text{C.V.}(X)$ ,

The shares of company Y are more stable in value.

**Activity :** Construct the table showing the frequencies of words with different number of letters occurring in the following passage, omitting punctuation marks. Take the number of letters in each word as one variable and obtain the mean, S.D. and the coefficient of variation of its distribution.

*“Take up one idea. Make that one idea your life – think of it, dream of it, live on that idea. Let the brain, muscles, nerves, every part of your body, be full of that idea, and just leave every other idea alone. This is way to success.”*

**EXERCISE 8.3**

- The means of two samples of sizes 60 and 120 respectively are 35.4 and 30.9 and the standard deviations 4 and 5. Obtain the standard deviation of the sample of size 180 obtained by combining the two sample.
- For a certain data, following information is available.

	X	Y
Mean	13	17
S. D.	3	2
Size	20	30

Obtain the combined standard deviation.

- Calculate coefficient of variation of marks secured by a student in the exam, where the marks are: 85, 91, 96, 88, 98, 82
- Find the coefficient of variation of a sample which has mean equal to 25 and standard deviation of 5.
- A group of 65 students of class XI have their average height is 150.4 cm with coefficient of variance 2.5%. What is the standard deviation of their height?
- Two workers on the same job show the following results:

	Worker P	Worker Q
Mean time for completing the job (hours)	33	21
Standard Deviation (hours)	9	7

- Regarding the time required to complete the job, which worker is more consistent?

- Which worker seems to be faster in completing the job?
- A company has two departments with 42 and 60 employees respectively. Their average weekly wages are Rs. 750 and Rs. 400. The standard deviations are 8 and 10 respectively.
    - Which department has a larger bill?
    - Which department has larger variability in wages?
  - The following table gives weights of the students of two classes. Calculate the coefficient of variation of the two distributions. Which series is more variable?

Weight (in kg)	Class A	Class B
30-40	22	13
40-50	16	10
50-60	12	17

- Compute coefficient of variation for team A and team B.

No. of goals	0	1	2	3	4
No. of matches played by team A	19	6	5	16	14
No. of matches played by team B	16	14	10	14	16

Which team is more consistent?

- Given below is the information about marks obtained in Mathematics and Statistics by 100 students in a class. Which subject shows the highest variability in marks?

	Mathematics	Statistics
Mean	20	25
S.D.	2	3

**Range :**

**Activity 1 :**

The daily sale of wheat in a certain shop is given below.

Day	Monday	Tuesday	Wednesday	Thursday	Friday	Saturday
Sale in Kg	135	39	142.5	78	120.5	93

Then  $L =$  \_\_\_\_\_  $S =$  \_\_\_\_\_  $\text{Range } L - S =$  \_\_\_\_\_

**Activity 2 :**

Neeraj Chopra is an Indian track and field athlete, who competes in the Javelin throw.

The following data reveals his record of throws in Asian Championships (A.C.) and World Championships (W.C.)

Championship	2015 (A.C.)	2016 (A.C.)	2017 (A.C.)	2018 (A.C.)	2013 (W.C.)	2016 (W.C.)	2017 (W.C.)
Throw (Meters)	70.50	77.60	85.23	88.06	66.75	86.48	82.26

Then L = \_\_\_\_\_ S = \_\_\_\_\_

Range L – S = \_\_\_\_\_

**Variance and Standard Deviation :**

**Activity 1 :**

The marks scored in a test by seven randomly selected students are

3	4	6	2	8	8	5
---	---	---	---	---	---	---

Find the Variance and Standard Deviation of these seven students.

**Solution :**

$$\text{Mean } \bar{x} = \frac{3+4 + + + + +5}{7} = \frac{36}{7}$$

The deviation from mean for each observation is  $(x - \bar{x})$

$3 - \frac{36}{7}$				$8 - \frac{36}{7}$		$5 - \frac{36}{7}$
$-\frac{15}{7}$				$\frac{20}{7}$		

The deviations squared are  $(x - \bar{x})^2$

$\frac{225}{49}$				$\frac{400}{49}$		
------------------	--	--	--	------------------	--	--

$$\text{Variance} = \frac{\sum (x - \bar{x})^2}{n}$$

$$\text{Standard Deviation} = \sqrt{\text{Variance}} = \sqrt{\quad} =$$

**Activity 2 :**

The number of centuries scored in a year by seven randomly selected batsmen are

3	5	6	3	7	6	4
---	---	---	---	---	---	---

Find the Variance and Standard Deviation of these seven batsmen.

**Solution :**

$x$	3	5	6	3	7	6	4	Result
$x^2$	9							
$\sum x$	3	+	+	+	+	+	+	=
$\sum x^2$	81	+	+	+	+	49	+	=
Variance	$= \sigma^2$	$= \frac{\sum x^2}{n} - \left(\frac{\sum x}{n}\right)^2$				$= \frac{7(\quad) - (\quad)^2}{7}$	$= \frac{7(\quad) - (\quad)^2}{49}$	=
Standard Deviation	$\sigma$	$= \sqrt{\text{Variance}} = \sqrt{\quad} =$						



**Let's Remember**

- **Range = Largest Value – Smallest Value = L – S**
- **Variance and Standard Deviation for raw data :**

Let the variable X takes the values  $x_1, x_2, x_3, \dots, x_n$ .

Let,  $\bar{x}$  be the arithmetic mean. Then,

$$\text{Var}(X) = \sigma^2 = \frac{1}{n} \sum_{i=1}^n (x_i - \bar{x})^2 = \frac{\sum_{i=1}^n x_i^2}{n} - \bar{x}^2$$

Where,  $\bar{x} = \frac{\sum x_i}{n}$

And S. D. =  $\sigma = \sqrt{\text{Var}(X)}$

- **Variance and Standard Deviation for frequency distribution :**

$$\begin{aligned} \text{Var}(X) \sigma^2 &= \frac{1}{n} \sum_{i=1}^n f_i (x_i - \bar{x})^2 \\ &= \frac{\sum_{i=1}^n f_i x_i^2}{N} - \bar{x}^2 \end{aligned}$$

Where,  $\bar{x} = \frac{\sum f_i x_i}{N}$

and  $\sum f_i = N = \text{Total frequency}$

S. D. =  $\sqrt{\text{Var}(X)}$

- **Change of origin and scale method :**

Let  $u = \frac{X - A}{h}$

Then  $\text{Var}(u) = \sigma_u^2 = \frac{\sum_{i=1}^n f_i u_i^2}{N} - \bar{u}^2$

And  $\text{Var}(X) = h^2 \cdot \text{Var}(u)$

i.e.  $\sigma_x^2 = h^2 \sigma_u^2$

S.D. is  $\sigma_x = h \sigma_u$

▪ **Standard Deviation for Combined data :**

$$\sigma_c = \sqrt{\frac{n_1(\sigma_1^2 + d_1^2) + n_2(\sigma_2^2 + d_2^2)}{n_1 + n_2}}$$

Where,  $d_1 = \bar{x}_1 - \bar{x}_c$  and  $d_2 = \bar{x}_2 - \bar{x}_c$

▪ **Coefficient of Variation :**

$$\text{C. V.} = 100 \times \frac{\sigma}{\bar{x}}$$

**MISCELLANEOUS EXERCISE - 8**

**(I) Select the correct option from the given alternatives :**

- 1) If there are 10 values each equal to 10, then S.D. of these values is : \_\_\_\_\_.  
 A) 100                                      B) 20  
 C) 0    D) 10
- 2) Number of patients who visited cardiologists are 13, 17, 11, 15 in four days then standard deviation (approximately) is  
 A) 5 patients                                B) 4 patients  
 C) 10 patients                                D) 15 patients
- 3) If the observations of a variable X are, -4, -20, -30, -44 and -36, then the value of the range will be:  
 A) -48                                         B) 40  
 C) -40                                         D) 48
- 4) The standard deviation of a distribution divided by the mean of the distribution and expressing in percentage is called:  
 A) Coefficient of Standard deviation  
 B) Coefficient of skewness  
 C) Coefficient of quartile deviation  
 D) Coefficient of variation

- 5) If the S.D. of first n natural numbers is  $\sqrt{2}$ , then the value of n must be \_\_\_\_\_.  
 A) 5    B) 4  
 C) 7    D) 6
- 6) The positive square root of the mean of the squares of the deviations of observations from their mean is called:  
 A) Variance                                    B) Range  
 C) S.D.                                         D) C.V.
- 7) The variance of 19, 21, 23, 25 and 27 is 8. The variance of 14, 16, 18, 20 & 22 is:  
 A) Greater than 8                            B) 8  
 C) Less than 8                                D)  $8 - 5 = 3$
- 8) For any two numbers SD is always  
 A) Twice the range                          B) Half of the range  
 C) Square of the range                      D) None of these
- 9) Given the heights (in cm) of two groups of students:  
 Group A : 131 cm, 150 cm, 147 cm, 138 cm, 144 cm  
 Group B : 139 cm, 148 cm, 132 cm, 151 cm, 140 cm  
 Which of the following is / are the true?  
 I) The ranges of the heights of the two groups of students are the same.  
 II) The means of the heights of the two groups of students are the same.  
 A) I only    B) II only    C) Both I and II  
 D) None
- 10) Standard deviation of data is 12 and mean is 72 then coefficient of variation is  
 A) 13.67%                                      B) 16.67%  
 C) 14.67%                                      D) 15.67%

**(II) Answer the following :**

1. 76, 57, 80, 103, 61, 63, 89, 96, 105, 72  
 Find the range for the following data.
2. 116, 124, 164, 150, 149, 114, 195, 128, 138, 203, 144

3. Given below the frequency distribution of weekly wages of 400 workers. Find the range.

Weekly wages (in '00 Rs.)	10	15	20	25	30	35	40
No. of workers	45	63	102	55	74	36	25

4. Find the range of the following data

Classes	115-125	125-135	135-145	145-155	155-165	165-175
Fre-quency	1	4	6	1	3	5

Find variance and S.D. for the following set of numbers.

5. 25, 21, 23, 29, 27, 22, 28, 23, 21, 25
6. 125, 130, 150, 165, 190, 195, 210, 230, 245, 260
7. Following data gives no. of goals scored by a team in 100 matches. Compute the standard deviation.

No. of Goals Scored	0	1	2	3	4	5
No. of matches	5	20	25	15	20	5

8. Compute the variance and S.D. for the following data:

X	62	30	64	47	63	46	35	28	60
F	5	8	3	4	5	7	8	3	7

9. Calculate S.D. from following data.

Age (In yrs)	20-29	30-39	40-49	50-59	60-69	70-79	80-89
Freq.	65	100	55	87	42	38	13

10. Given below is the frequency distribution of marks obtained by 100 students. Compute arithmetic mean and S.D.

Marks	40-49	50-59	60-69	70-79	80-89	90-99
No. of students	4	12	25	28	26	5

11. The arithmetic mean and standard deviation of a series of 20 items were calculated by a student as 20 cms and 5 cms respectively. But while calculating them, an item 13 was

misread as 30. Find the corrected mean and standard deviation.

12. The mean and S.D. of a group of 50 observation are 40 and 5 respectively. If two more observations 60 and 72 are added to the set, find the mean and S.D. of 52 items.
13. The mean height of 200 students is 65 inches. The mean heights of boys and girls are 70 inches and 62 inches respectively and the standard deviations are 8 and 10 respectively. Find the number of boys and the combined S.D.
14. From the following data available for 5 pairs of observations of two variables x and y, obtain the combined S.D. for all 10 observations.

$$\text{Where, } \sum_{i=1}^n x_i = 30, \sum_{i=1}^n y_i = 40, \sum_{i=1}^n x_i^2 = 220,$$

$$\sum_{i=1}^n y_i^2 = 340$$

15. Calculate coefficient of variation of the following data.  
23, 27, 25, 28, 21, 14, 16, 12, 18, 16
16. Following data relates to the distribution of weights of 100 boys and 80 girls in a school.

	Boys	Girls
Mean	60	47
Variance	16	9

Which of the two is more variable?

17. The mean and standard deviations of two bands of watches are given below :

	Brand-I	Brand-II
Mean	36 months	48 months
S.D.	8 months	10 months

Calculate coefficient of variation of the two brands and interpret the results.

18. Calculate coefficient of variation for the data given below

Size (cm)	5-8	8-11	11-14	14-17	17-20	20-23	23-26
No of items	3	14	13	16	19	24	11

19. Calculate coefficient of variation for the data given below

Income (Rs.)	3000-4000	4000-5000	5000-6000	6000-7000	7000-8000	8000-9000	9000-10000
No. of families	24	13	15	28	12	8	10

20. Compute coefficient of variations for the following data to show whether the variation is greater in the yield or in the area of the field.

Year	Area (in acres)	Yield (in lakhs)
2011-12	156	62
2012-13	135	70
2013-14	128	68
2014-15	117	76
2015-16	141	65
2016-17	154	69
2017-18	142	71

21. There are two companies U and V which manufacture cars. A sample of 40 cars each from these companies are taken and the average running life (in years) is recorded.

Life ( in years)	No of Cars	
	Company U	Company V
0-5	5	14
5-10	18	8
10-15	17	18

Which company shows greater consistency?

22. The means and S.D. of weights and heights of 100 students of a school are as follows.

	Weights	Heights
Mean	56.5 kg	61 inches
S.D.	8.76 kg	12.18 inches

Which shows more variability, weights or heights?



# 9 Probability



## Let's Learn

- Basic Terminologies
- Concept of probability
- Addition Theorem
- Conditional probability
- Multiplication Theorem
- Baye's Theorem
- Odds



## Let's Recall

### 9.1.1 Basic Terminologies

**Random Experiment :** Suppose an experiment having more than one outcome. All possible results are known but the actual result cannot be predicted such an experiment is called a random experiment.

**Outcome:** A possible result of random experiment is called a possible outcome of the experiment.

**Sample space:** The set of all possible outcomes of a random experiment is called the sample space. The sample space is denoted by  $S$  or Greek letter omega ( $\Omega$ ). The number of elements in  $S$  is denoted by  $n(S)$ . A possible outcome is also called a sample point since it is an element in the sample space.

**Event:** A subset of the sample space is called an event.

**Favourable Outcome:** An outcome that belongs to the specified event is called a favourable outcome.

### Types of Events:

**Elementary Event:** An event consisting of a single outcome is called an elementary event.

**Certain Event:** The sample space is called the certain event if all possible outcomes are favourable outcomes. i.e. the event consists of the whole sample space.

**Impossible Event:** The empty set is called impossible event as no possible outcome is favorable.

### Algebra of Events:

Events are subsets of the sample space. Algebra of events uses operations in set theory to define new events in terms of known events.

**Union of Two Events:** Let  $A$  and  $B$  be two events in the sample space  $S$ . The union of  $A$  and  $B$  is denoted by  $A \cup B$  and is the set of all possible outcomes that belong to at least one of  $A$  and  $B$ .

**Ex.** Let  $S =$  Set of all positive integers not exceeding 50;

Event  $A =$  Set of elements of  $S$  that are divisible by 6; and

Event  $B =$  Set of elements of  $S$  that are divisible by 9. Find  $A \cup B$

**Solution :**  $A = \{6, 12, 18, 24, 30, 36, 42, 48\}$

$B = \{9, 18, 27, 36, 45\}$

$\therefore A \cup B = \{6, 9, 12, 18, 24, 27, 30, 36, 42, 45, 48\}$  is the set of elements of  $S$  that are divisible by 6 or 9.

**Exhaustive Events:** Two events  $A$  and  $B$  in the sample space  $S$  are said to be exhaustive if  $A \cup B = S$ .

**Example:** Consider the experiment of throwing a die and noting the number on the top.

Let  $S$  be the sample space

$$\therefore S = \{1,2,3,4,5,6\}$$

Let,  $A$  be the event that this number does not exceed 4, and

$B$  be the event that this number is not smaller than 3.

$$\text{Then } A = \{1,2,3,4\} \quad B = \{3,4,5,6\}$$

$$\text{and therefore, } A \cup B = \{1,2,3,4,5,6\} = S$$

$\therefore$  Events  $A$  and  $B$  are exhaustive.

**Intersection of Two Events:** Let  $A$  and  $B$  be two events in the sample space  $S$ . The intersection of  $A$  and  $B$  is the event consisting of outcomes that belong to both the events  $A$  and  $B$ .

Example, Let  $S =$  Set of all positive integers not exceeding 50,

Event  $A =$  Set of elements of  $S$  that are divisible by 3, and

Event  $B =$  Set of elements of  $S$  that are divisible by 5.

Then  $A = \{3,6,9,12,15,18,21,24,27,30,33,36,39,42,45,48\}$ ,

$$B = \{5,10,15,20,25,30,35,40,45,50\}$$

$\therefore A \cap B = \{15,30,45\}$  is the set of elements of  $S$  that are divisible by both 3 and 5.

**Mutually Exclusive Events:** Event  $A$  and  $B$  in the sample space  $S$  are said to be mutually exclusive if they have no outcomes in common. In other words, the intersection of mutually exclusive events is empty. Mutually exclusive events are also called disjoint events.

**Example:** Let  $S =$  Set of all positive integers not exceeding 50,

Event  $A =$  set of elements of  $S$  that are divisible by 8, and

Event  $B =$  set of elements of  $S$  that are divisible by 13.

$$\text{Then } A = \{8,16,24,32,40,48\},$$

$$B = \{13,26,39\}$$

$\therefore A \cap B = \phi$  because no element of  $S$  is divisible by both 8 and 13.

**Note:** If two events  $A$  and  $B$  are mutually exclusive and exhaustive, then they are called complementary events.

Symbolically,  $A$  and  $B$  are complementary events if  $A \cup B = S$  and  $A \cap B = \phi$ .

**Notation:** Complement of an event  $A$  is denoted by  $A'$ ,  $\bar{A}$  or  $A^c$ . The following table shows how the operations of complement, union, and intersection can be combined to define more events.

Operation	Interpretation
$A', \bar{A}$ or $A^c$	Not $A$ .
$A \cup B$	At least, one of $A$ and $B$
$A \cap B$	Both $A$ and $B$
$(A' \cap B) \cup (A \cap B')$	Exactly one of $A$ and $B$
$(A' \cap B') = (A \cup B)'$	Neither $A$ nor $B$

### SOLVED EXAMPLES:

**Ex. 1:** Describe the sample space of the experiment when a coin and a die are thrown simultaneously.

**Solution :** Sample space  $S = \{(H,1), (H,2), (H,3), (H,4), (H,5), (H,6), (T,1), (T,2), (T,3), (T,4), (T,5), (T,6)\}$

**Ex. 2:** Sunita and Samrudhi who live in Mumbai wish to go on holiday to Delhi together. They can travel to Delhi from Mumbai either by car or by train or plane and on reaching Delhi they can go for city-tour either by bus or Taxi. Describe the sample space, showing all the combined outcomes of different ways they could complete city-tour from Mumbai.

**Solution :** Sample space

$S = \{(car, bus), (car, taxi), (train, bus), (train, taxi), (plane, bus), (plane, taxi)\}$

**Ex. 3:** Three coins are tossed. Events  $E_1, E_2, E_3$  and  $E_4$  are defined as follows.

$E_1$  : Occurrence of at least two heads.

$E_2$  : Occurrence of at least two tails.

$E_3$  : Occurrence of at most one head.

$E_4$  : Occurrence of two heads.

Describe the sample space and events  $E_1, E_2, E_3$  and  $E_4$ .

Find  $E_1 \cup E_4, E_3'$ . Also check whether

i)  $E_1$  and  $E_2$  are mutually exclusive

ii)  $E_2$  and  $E_3$  are equal

**Solution :** Sample space

$S = \{HHH, HHT, HTH, HTT, THH, THT, TTH, TTT\}$

$E_1 : \{HHH, HHT, HTH, THH\}$

$E_2 : \{HTT, THT, TTH, TTT\}$

$E_3 : \{HTT, THT, TTH, TTT\}$

$E_4 : \{HHT, HTH, THH, \}$

$E_1 \cup E_4 = \{HHT, HTH, THH, HHH, HHT\}$

$E_3 = \{HHH, HHT, HTH, THH\}$

i)  $E_1 \cap E_2 = \{\} = \phi$

$\therefore E_1$  and  $E_2$  are mutually exclusive.

ii)  $E_2$  and  $E_3$  are equal.

**9.1.2 Concept of Probability:**

A random experiment poses uncertainty regarding the actual result of the experiment, even though all possible outcomes are already known. The classical definition of probability is based on the assumption that all possible outcomes of an experiment are equally likely.

**9.1.3 Equally likely outcomes:**

All possible outcomes of a random experiment are said to be equally likely if none of them can be preferred over others.

**9.1.4 Probability of an Event:**

The probability of an event A is defined as

$$P(A) = \frac{n(A)}{n(S)}$$

Where,

$n(A)$  = number of outcomes favorable for event A,

$n(S)$  = number of all possible outcomes.

**9.1.5 Elementary Properties of Probability:**

1)  $A'$  is complement of A and therefore  $P(A') = 1 - P(A)$

2) For any event A in S,  $0 \leq P(A) \leq 1$

3) For the impossible event  $\phi$ ,  $P(\phi) = 0$

4) For the certain event S,  $P(S) = 1$

5) If  $A_1$  and  $A_2$  two mutually exclusive events then  $P(A_1 \cup A_2) = P(A_1) + P(A_2)$

6) If  $A \subseteq B$ , then  $P(A) \leq P(B)$  and  $P(A' \cap B) = P(B) - P(A)$

7) Addition theorem: For any two events A and B of a sample space S,

$$P(A \cup B) = P(A) + P(B) - P(A \cap B)$$

8) For any two events A and B,  
 $P(A \cap B') = P(A) - P(A \cap B)$

9) For any three events A, B and C of a sample space S,

$$P(A \cup B \cup C) = P(A) + P(B) + P(C) - P(A \cap B) - P(B \cap C) - (P(A \cap C) + P(A \cap B \cap C))$$

10) If  $A_1, A_2, \dots, A_m$  are mutually exclusive events in S, then  $P(A_1 \cup A_2 \cup \dots \cup A_m) = P(A_1) + P(A_2) + \dots + P(A_m)$

**Remark:** Consider a finite sample space S with n finite elements.

$S = \{a_1, a_2, a_3, \dots, a_n\}$ . Let  $A_1, A_2, A_3, \dots, A_n$  be elementary events given by  $A_i = \{a_i\}$  with probability  $P(A_i)$ . We have

$$P(S) = P(A_1) + P(A_2) + \dots + P(A_n) = 1 \quad \dots \text{(I)}$$

When all elementary events given by  $A_i$  ( $i = 1, 2, 3, \dots, n$ ) are equally likely, that is  $P(A_1) = P(A_2) = \dots = P(A_n)$ , then from (I), we have  $P(A_i) = 1/n, i = 1, 2, \dots, n$

If  $A$  is any event made up of  $m$  such elementary events, i.e.

$A = A_1 \cup A_2 \cup A_3 \cup \dots \cup A_m$ , then using property 10, we have

$$P(A) = P(A_1) + P(A_2) + P(A_3) + \dots + P(A_m)$$

$$= \left(\frac{1}{n}\right) + \left(\frac{1}{n}\right) + \dots + \left(\frac{1}{n}\right) \text{ (m times)}$$

$$\therefore P(A) = \frac{m}{n} = \frac{n(A)}{n(S)} \quad \dots \text{(II)}$$

$\therefore P(A) = (\text{Number of favourable outcomes for the occurrence of event } A) / (\text{Total number of distinct possible outcomes in the sample space } S)$

### SOLVED EXAMPLES

**Ex. 1)** If  $A \cup B \cup C = S$  (the sample space) and  $A, B$  and  $C$  are mutually exclusive events, can the following represent probability assignment?

i)  $P(A) = 0.2, P(B) = 0.7, P(C) = 0.1$

ii)  $P(A) = 0.4, P(B) = 0.6, P(C) = 0.2$

**Solution:**

i) Since  $P(S) = P(A \cup B \cup C)$

$$= P(A) + P(B) + P(C) \text{ [Property 10]}$$

$$= 0.2 + 0.7 + 0.1 = 1$$

$$\text{and } 0 \leq P(A), P(B), P(C) \leq 1$$

$\therefore$  The given values can represent the probability assignment.

ii) Since

$$P(S) = P(A \cup B \cup C)$$

$$= P(A) + P(B) + P(C) \text{ [Property 10]}$$

$$= 0.4 + 0.6 + 0.2 = 1.2 > 1$$

$\therefore P(A), P(B)$  and  $P(C)$  cannot represent probability assignment.

**Ex. 2)** One card is drawn at random from a pack of 52 cards. What is the probability that it is a King or Queen?

**Solution:**

Random Experiment = One card is drawn at random from a pack of 52 cards

$$\therefore n(S) = {}^{52}C_1 = 52.$$

Let event  $A$ : Card drawn is King

and event  $B$ : Card drawn is Queen.

Since pack of 52 cards contains, 4 king cards from which any one king card can be drawn in  ${}^4C_1 = 4$  ways.  $\therefore n(A) = 4$

$$\therefore P(A) = \frac{n(A)}{n(S)} = \frac{4}{52}$$

Similarly, a pack of 52 cards contains, 4 queen cards from which any one queen card can be drawn in  ${}^4C_1 = 4$  ways.  $\therefore n(B) = 4$

$$\therefore P(B) = \frac{n(B)}{n(S)} = \frac{4}{52}$$

Since  $A$  and  $B$  are mutually exclusive events

$\therefore$  required probability  $P(\text{king or queen})$

$$= P(A \cup B) = P(A) + P(B) = \frac{4}{52} + \frac{4}{52} = \frac{2}{13}$$

**Ex. 3:** Five employees in a company of 20 are graduates. If 3 are selected out of 20 at random. What is the probability that

i) they are all graduates?

ii) there is at least one graduate among them?

**Solution :** Out of 20 employees, any 3 are to be selected in  ${}^{20}C_3$  ways.

$\therefore n(S) = {}^{20}C_3$  where S is the sample space.

Let event A: All 3 selected employees are graduates.

Out of 5 graduate any 3 can be selected in  ${}^5C_3$  ways.

$$\therefore \text{required probability } P(A) = \frac{{}^5C_3}{{}^{20}C_3} = \frac{10}{1140} = \frac{1}{114}$$

Let event B: At least one graduate employee is selected.

$\therefore B'$  is the event that no graduate employee is selected.

Since out of 20 employee, 5 are graduates, therefore from the remaining 15 non-graduate any 3 non-graduates can be selected in  ${}^{15}C_3$  ways.

$$\therefore P(B') = \frac{{}^{15}C_3}{{}^{20}C_3} = \frac{455}{1140} = \frac{91}{228}$$

$\therefore$  required probability

$$P(B) = 1 - P(B') = 1 - \frac{91}{228} = \frac{137}{228}$$

**Ex. 4)** The letters of the word STORY be arranged randomly. Find the probability that

- T and Y are together.
- arrangement begins with T and end with Y.

**Solution:**

The word STORY consists of 5 different letters, which can be arranged among themselves in  $5!$  ways.

$\therefore n(S) = 5! = 120$

- Event A: T and Y are a together.

Let us consider T and Y as a single letter say X. Therefore, now we have four different

letters X, S, O and R which can be arranged among themselves in  $4! = 24$  different ways. After this is done, two letters T and Y can be arranged among themselves in  $2! = 2$  ways. Therefore, by fundamental principle, total number of arrangements in which T and Y are always together is  $24 \times 2 = 48$ .

$$\therefore \text{required probability } P(A) = \frac{48}{120} = \frac{2}{5}$$

- Event B: An arrangement begins with T and ends with Y.

Remaining 3 letters in the middle can be arranged in  $3! = 6$  different ways.

$$\therefore \text{required probability } P(B) = \frac{6}{120} = \frac{1}{20}$$

### EXERCISE 9.1

- There are four pens: Red, Green, Blue and Purple in a desk drawer of which two pens are selected at random one after the other with replacement. State the sample space and the following events.
  - A : Selecting at least one red pen.
  - B : Two pens of the same color are not selected.
- A coin and a die are tossed simultaneously. Enumerate the sample space and the following events.
  - A : Getting a Tail and an Odd number
  - B : Getting a prime number
  - C : Getting a head and a perfect square.
- Find  $n(S)$  for each of the following random experiments.
  - From an urn containing 5 gold and 3 silver coins, 3 coins are drawn at random
  - 5 letters are to be placed into 5 envelopes such that no envelope is empty.
  - 6 books of different subjects arranged on a shelf.
  - 3 tickets are drawn from a box containing 20 lottery tickets.

- 4) Two fair dice are thrown. State the sample space and write the favorable outcomes for the following events.
  - a) A : Sum of numbers on two dice is divisible by 3 or 4.
  - b) B : Sum of numbers on two dice is 7.
  - c) C : Odd number on the first die.
  - d) D : Even number on the first die.
  - e) Check whether events A and B are mutually exclusive and exhaustive.
  - f) Check whether events C and D are mutually exclusive and exhaustive.
- 5) A bag contains four cards marked as 5, 6, 7 and 8. Find the sample space if two cards are drawn at random
  - a) with replacement
  - b) without replacement
- 6) A fair die is thrown two times. Find the probability that
  - a) sum of the numbers on them is 5
  - b) sum of the numbers on them is at least 8
  - c) first throw gives a multiple of 2 and second throw gives a multiple of 3.
  - d) product of numbers on them is 12.
- 7) Two cards are drawn from a pack of 52 cards. Find the probability that
  - a) one is a face card and the other is an ace card
  - b) one is club and the other is a diamond
  - c) both are from the same suit.
  - d) both are red cards
  - e) one is a heart card and the other is a non heart card
- 8) Three cards are drawn from a pack of 52 cards. Find the chance that
  - a) two are queen cards and one is an ace card
  - b) at least one is a diamond card
  - c) all are from the same suit
  - d) they are a king, a queen and a jack
- 9) From a bag containing 10 red, 4 blue and 6 black balls, a ball is drawn at random. Find the probability of drawing
  - a) a red ball.
  - b) a blue or black ball.
  - c) not a black ball.
- 10) A box contains 75 tickets numbered 1 to 75. A ticket is drawn at random from the box. Find the probability that,
  - a) Number on the ticket is divisible by 6
  - b) Number on the ticket is a perfect square
  - c) Number on the ticket is prime
  - d) Number on the ticket is divisible by 3 and 5
- 11) What is the chance that a leap year, selected at random, will contain 53 sundays?.
- 12) Find the probability of getting both red balls, when from a bag containing 5 red and 4 black balls, two balls are drawn, i) with replacement ii) without replacement
- 13) A room has three sockets for lamps. From a collection 10 bulbs of which 6 are defective. At night a person selects 3 bulbs, at random and puts them in sockets. What is the probability that i) room is still dark ii) the room is lit
- 14) Letters of the word MOTHER are arranged at random. Find the probability that in the arrangement
  - a) vowels are always together
  - b) vowels are never together
  - c) O is at the begining and end with T
  - d) starting with a vowel and end with a consonant
- 15) 4 letters are to be posted in 4 post boxes. If any number of letters can be posted in any of the 4 post boxes, what is the probability that each box contains only one letter?

- 16) 15 professors have been invited for a round table conference by Vice chancellor of a university. What is the probability that two particular professors occupy the seats on either side of the Vice Chancellor during the conference.
- 17) A bag contains 7 black and 4 red balls. If 3 balls are drawn at random find the probability that (i) all are black (ii) one is black and two are red.

### 9.2.1 Addition theorem for two events

For any two events A and B of a sample space S,  $P(A \cup B) = P(A) + P(B) - P(A \cap B)$ . This is the property (7) that we had seen earlier. Since it is very important we give its proof. The other properties can also be proved in the same way.

This can be proved by two methods

- Using the definition of probability.
- Using Venn diagram.

We assume that all outcomes are equally likely and sample space S contains finite number of outcomes.

#### (a) Using the definition of probability:

If A and B are any two events, then event  $A \cup B$  can be decomposed into two mutually exclusive events  $A \cap B'$  and B

$$\text{i.e. } A \cup B = (A \cap B') \cup B$$

$$\begin{aligned} \therefore P(A \cup B) &= P[(A \cap B') \cup B] \\ &= P(A \cap B') + P(B) \\ &\quad \text{[By property 10]} \\ &= P(A) - P(A \cap B) + P(B) \\ &\quad \text{[By property 8]} \end{aligned}$$

$$\text{Hence } P(A \cup B) = P(A) + P(B) - P(A \cap B)$$

#### (b) Using Venn diagram:

Let  $n(S) = n$  = Total no. of distinct possible outcomes in the sample space S.

$n(A) = x$ , number of favourable outcomes for the occurrence of event A.

$n(B) = y$ , number of favourable outcomes for the occurrence of event B.

$n(A \cap B) = z$ , the number of favourable outcomes for the occurrence of both event A and B.

$$\therefore P(A) = \frac{n(A)}{n(S)} = \frac{x}{n}, P(B) = \frac{n(B)}{n(S)} = \frac{y}{n}$$

$$P(A \cap B) = \frac{n(A \cap B)}{n(S)} = \frac{z}{n}$$

As all outcomes are equally likely.

From Venn diagram

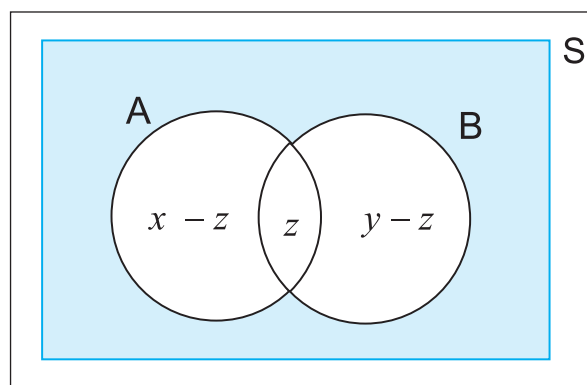

Fig. 9.1

$$n(A \cup B) = (x - z) + z + (y - z)$$

$$\therefore n(A \cup B) = x + y - z$$

$$n(A \cup B) = n(A) + n(B) - n(A \cap B)$$

Dividing both sides by  $n(S)$ , we get

$$\frac{n(A \cup B)}{n(S)} = \frac{n(A)}{n(S)} + \frac{n(B)}{n(S)} - \frac{n(A \cap B)}{n(S)}$$

$$\therefore P(A \cup B) = P(A) + P(B) - P(A \cap B).$$

**SOLVED EXAMPLES**

**Ex. 1)** Two dice are thrown together. What is the probability that,

- i) Sum of the numbers is divisible by 3 or 4?
- ii) Sum of the numbers is neither divisible by 3 nor 5?

**Solution :** Let S be the sample space

$$\text{Let } N_1 = N_2 = \{1, 2, 3, 4, 5, 6\}$$

$$S = N_1 \times N_2 = \{(x, y) / x \in N_1, y \in N_2\}$$

$$n(S) = 36$$

- i) Let event A: Sum of the numbers is divisible by 3

∴ possible sums are 3, 6, 9, 12.

$$\therefore A = \{(1, 2), (1, 5), (2, 1), (2, 4), (3, 3), (3, 6), (4, 2), (4, 5), (5, 1), (5, 4), (6, 3), (6, 6)\}$$

$$\therefore n(A) = 12 \therefore P(A) = n(A) / n(S) = 12/36$$

- Let event B: Sum of the numbers is divisible by 4.

∴ possible sums are 4, 8, 12

$$\therefore B = \{(1, 3), (2, 2), (2, 6), (3, 1), (3, 5), (4, 4), (5, 3), (6, 2), (6, 6)\}$$

$$\therefore n(B) = 9 \therefore P(B) = n(B) / n(S) = \frac{9}{36}$$

∴ Event  $A \cap B$ : Sum of the numbers is divisible by 3 and 4 i.e. divisible by 12.

∴ possible Sum is 12

$$\therefore A \cap B = \{(6, 6)\}$$

$$\therefore n(A \cap B) = 1$$

$$\therefore P(A \cap B) = n(A \cap B) / n(S) = \frac{1}{36}$$

P (Sum of the numbers is divisible by 3 or 4)

$$P(A \cup B) = P(A) + P(B) - P(A \cap B)$$

$$= \frac{12}{36} + \frac{9}{36} - \frac{1}{36} = \frac{20}{36} = \frac{5}{9}$$

- ii) Let event A: Sum of the numbers is divisible by 3

$$\therefore P(A) = \frac{12}{36}$$

Let event Y: Sum of the numbers is divisible by 5.

∴ possible sums are 5, 10

$$\therefore Y = \{(1, 4), (2, 3), (3, 2), (4, 1), (4, 6), (5, 5), (6, 4)\}$$

$$\therefore n(Y) = 7 \therefore P(Y) = \frac{n(Y)}{n(S)} = \frac{7}{36}$$

∴ Event  $A \cap Y$ : sum is divisible by 3 and 5

$$\therefore A \cap Y = \phi$$

[X and Y are mutually exclusive events]

$$\therefore P(A \cap Y) = \frac{n(A \cap Y)}{n(S)} = 0$$

∴ required probability = P(Sum of the numbers is neither divisible by 3 nor 5)

$$\begin{aligned} P(A' \cap Y') &= P(A \cup Y)' \text{ [De'Morgan's law]} \\ &= 1 - P(A \cup Y) \text{ [Property 1]} \\ &= 1 - [P(A) + P(Y) - P(A \cap Y)] \\ &= 1 - \frac{19}{36} = \frac{17}{36} \end{aligned}$$

**Ex. 2)** The probability that a student will solve problem A is  $\frac{2}{3}$ , and the probability that he will not solve problem B is  $\frac{5}{9}$ . If the probability that student solves at least one problem is  $\frac{4}{5}$ , what is the probability that he will solve both the problems?

**Solution :** Let event A: student solves problem A

$$\therefore P(A) = \frac{2}{3}$$

event B: student solves problem B.

∴ event B': student will not solve problem B.

$$\therefore P(B') = \frac{5}{9}$$

$$\therefore P(B) = 1 - P(B') = 1 - \frac{5}{9} = \frac{4}{9}$$

Probability that student solves at least one problem =  $P(A \cup B) = \frac{4}{5}$

$$\therefore P(A \cup B) = P(A) + P(B) - P(A \cap B)$$

$\therefore$  required probability = P(he will solve both the problems)

$$= P(A \cap B) = P(A) + P(B) - P(A \cup B)$$

$$= \frac{2}{3} + \frac{4}{9} - \frac{4}{5} = \frac{14}{45}$$

### EXERCISE 9.2

- 1) First 6 faced die which is numbered 1 through 6 is thrown then a 5 faced die which is numbered 1 through 5 is thrown. What is the probability that sum of the numbers on the upper faces of the dice is divisible by 2 or 3?
- 2) A card is drawn from a pack of 52 cards. What is the probability that,
  - i) card is either red or black?
  - ii) card is either black or a face card?
- 3) A girl is preparing for National Level Entrance exam and State Level Entrance exam for professional courses. The chances of her cracking National Level exam is 0.42 and that of State Level exam is 0.54. The probability that she clears both the exams is 0.11. Find the probability that (i) She cracks at least one of the two exams (ii) She cracks only one of the two (iii) She cracks none
- 4) A bag contains 75 tickets numbered from 1 to 75. One ticket is drawn at random. Find the probability that,
  - a) number on the ticket is a perfect square or divisible by 4
  - b) number on the ticket is a prime number or greater than 40
- 5) The probability that a student will pass in French is 0.64, will pass in Sociology is 0.45 and will pass in both is 0.40. What is the probability that the student will pass in at least one of the two subjects?
- 6) Two fair dice are thrown. Find the probability that number on the upper face of the first die is 3 or sum of the numbers on their upper faces is 6.
- 7) For two events A and B of a sample space S, if  $P(A) = \frac{3}{8}$ ,  $P(B) = \frac{1}{2}$  and  $P(A \cup B) = \frac{5}{8}$ . Find the value of the following.
  - a)  $P(A \cap B)$
  - b)  $P(A' \cap B')$
  - c)  $P(A' \cup B')$
- 8) For two events A and B of a sample space S, if  $P(A \cup B) = \frac{5}{6}$ ,  $P(A \cap B) = \frac{1}{3}$  and  $P(B') = \frac{1}{3}$ , then find P(A).
- 9) A bag contains 5 red, 4 blue and an unknown number m of green balls. If the probability of getting both the balls green, when two balls are selected at random is  $\frac{1}{7}$ , find m.
- 10) Form a group of 4 men, 4 women and 3 children, 4 persons are selected at random. Find the probability that, i) no child is selected ii) exactly 2 men are selected.
- 11) A number is drawn at random from the numbers 1 to 50. Find the probability that it is divisible by 2 or 3 or 10.

### 9.3.1 Conditional Probability:

Let S be a sample space associated with the given random experiment. Let A and B be any two events defined on the sample space S. Then the probability of occurrence of event A under the condition that event B has already occurred

and  $P(B) \neq 0$  is called conditional probability of event A given B and is denoted by  $P(A/B)$ .

### SOLVED EXAMPLES

**Ex.1)** A card is drawn from a pack of 52 cards, given that it is a red card, what is the probability that it is a face card.

**Solution :** Let event A: Red card is drawn and event B: face card is drawn

A card is drawn from a pack of 52 cards, therefore  $n(S) = 52$ . But we are given that red card is drawn, therefore our sample space reduces to event A only, which contains  $n(A) = 26$  sample points. Event A is called reduced or truncated sample space. Out of 26 red cards, 6 cards are favourable for face cards.

$\therefore P[\text{card drawn is face card given that it is a red card}] = P[B/A] = 6/26 = 3/13$

**Ex. 2)** A pair of dice is thrown. If sum of the numbers is an odd number, what is the probability that sum is divisible by 3?

**Solution :** Let Event A: sum is an odd number.

Event B: Sum is divisible by 3.

A pair of dice is thrown, therefore  $n(S) = 36$ . But we are given that sum is odd, therefore our sample space reduces to event A only as follows:

$A = \{(1,2), (1,4), (1,6), (2,1), (2,3), (2,5), (3,2), (3,4), (3,6), (4,1), (4,3), (4,5), (5,2), (5,4), (5,6), (6,1), (6,3), (6,5)\}$

$\therefore n(A) = 18$

Out of 18 sample points following 6 sample points are favourable for occurrence of event B

$B = \{(1, 2), (2, 1), (3, 6), (4, 5), (5, 4), (6, 3)\}$

$\therefore P[\text{sum is divisible by 3 given that sum is an odd number}] = P(B/A) = 6/18 = 1/3$

**9.3.2** Let S be a finite sample space, associated with the given random experiment, containing equally likely outcomes. Then we have the following result.

**Statement:** Conditional probability of event A given that event B has already occurred is given by

$$P(A/B) = \frac{P(A \cap B)}{P(B)}, P(B) \neq 0$$

(Read A/B as A given B)

Let S be a sample space associated with the given random experiment and  $n(S)$  be the number of sample points in the sample space S. Since we are given that event B has already occurred, therefore our sample space reduces to event B only, which contains  $n(B)$  sample points. Event B is also called reduced or truncated sample space. Now out of  $n(B)$  sample points, only  $n(A \cap B)$  sample points are favourable for occurrence of event A. Therefore, by definition of probability

$$P(A/B) = \frac{n(A \cap B)}{n(B)}, n(B) \neq 0$$

$$= \frac{\frac{n(A \cap B)}{n(S)}}{\frac{n(B)}{n(S)}}$$

$$\therefore P(A/B) = \frac{P(A \cap B)}{P(B)}, P(B) \neq 0$$

$$\text{Similarly } P(B/A) = \frac{P(A \cap B)}{P(A)}, P(A) \neq 0$$

### SOLVED EXAMPLES

**Ex. 1:** Find the probability that a single toss of a die will result in a number less than 4 if it is given that the toss resulted in an odd number.

**Solution :** Let event A: toss resulted in an odd number and

Event B: number is less than 4

$$\therefore A = \{1, 3, 5\} \therefore P(A) = 3/6 = \frac{1}{2}$$

$$B = \{1, 2, 3\} \therefore A \cap B = \{1, 3\}$$

$$\therefore P(A \cap B) = \frac{2}{6} = \frac{1}{3}$$

$\therefore P(\text{number is less than 4 given that it is odd})$

$$= P(B/A) = P(A \cap B) / P(A) = \left(\frac{1}{3}\right) / \left(\frac{1}{2}\right) = \frac{2}{3}$$

**Ex. 2)** If  $P(A') = 0.7$ ,  $P(B) = 0.7$ ,  $P(B/A) = 0.5$ , find  $P(A/B)$  and  $P(A \cup B)$ .

**Solution :** Since  $1 - P(A') = 0.7$

$$P(A) = 1 - P(A') = 1 - 0.7 = 0.3$$

$$\text{Now } P(B/A) = P(A \cap B) / P(A)$$

$$\therefore 0.5 = P(A \cap B) / 0.3$$

$$\therefore P(A \cap B) = 0.15$$

$$\text{Again } P(A/B) = P(A \cap B) / P(B)$$

$$= 0.15 / 0.7$$

$$\therefore P(A/B) = 3/14$$

Further, by addition theorem

$$P(A \cup B) = P(A) + P(B) - P(A \cap B)$$

$$= 0.3 + 0.7 - 0.15 = 0.85$$

### 9.3.3 Multiplication theorem:

**Statement:** Let S be sample space associated with the given random experiment. Let A and B be any two events defined on the sample space S. Then the probability of occurrence of both the events is denoted by  $P(A \cap B)$  and is given by

$$P(A \cap B) = P(A).P(B/A)$$

$$\text{Since } P(B/A) = \frac{P(A \cap B)}{P(A)}$$

$$\therefore P(A \cap B) = P(A).P(B/A)$$

$$\text{Similarly } P(A \cap B) = P(B).P(A/B)$$

### SOLVED EXAMPLES

**Ex. 1)** Two cards are drawn from a pack of 52 cards one after other without replacement. What is the probability that both cards are ace cards?

**Soln.:** Let event A: first card drawn is an Ace card.

Let event B: second card drawn is an Ace card.

$\therefore$  required probability = P(both are Ace cards)

$$= P(A \cap B) = P(A)P(A/B)$$

$$\text{Now } P(A) = \frac{4}{52} = \frac{1}{13}$$

Since first ace card is not replaced in the pack, therefore now we have 51 cards containing 3 ace cards

$\therefore$  Probability of getting second ace card under the condition that first ace card is not replaced in

$$\text{the pack} = P(B/A) = \frac{3}{51} = \frac{1}{17}$$

$$\therefore P(\text{both are ace cards}) = P(A \cap B)$$

$$= P(A)P(B/A) = \frac{1}{13} \times \frac{1}{17} = \frac{1}{221}$$

**Ex. 2)** An urn contains 4 black and 6 white balls. Two balls are drawn one after the other without replacement, what is the probability that both balls are black?

**Solution :** Let event A: first ball drawn in black.

Event B: second ball drawn is black.

$\therefore$  Required probability = P(both are black balls)

$$= P(A \cap B) = P(A)P(B/A)$$

$$\text{Now } P(A) = \frac{4}{10}$$

Since first black ball is not replaced in the urn, therefore now we have 9 balls containing 3 black balls.

∴ Probability of getting second black ball under the condition that first black is not replaced in the pack =  $P(B/A) = \frac{3}{9}$

$$\begin{aligned} \therefore P(\text{both are black balls}) &= P(A \cap B) \\ &= P(A)P(B/A) = \frac{4}{10} \times \frac{3}{9} = \frac{2}{15} \end{aligned}$$

### 9.3.4 Independent Events:

Let S be sample space associated with the given random experiment. Let A and B be any two events defined on the sample space S. If the occurrence of either event, does not affect the probability of the occurrence of the other event, then the two events A and B are said to be independent.

Thus, if A and B are independent events then,  $P(A/B) = P(A/B') = P(A)$  and

$$P(B/A) = P(B/A') = P(B)$$

**Remark:** If A and B are independent events then  $P(A \cap B) = P(A).P(B)$

$$\begin{aligned} \text{note that } P(A \cap B) &= P(A).(B/A) \\ &= P(A).P(B) \end{aligned}$$

$$\therefore P(A \cap B) = P(A).P(B)$$

In general, if  $A_1, A_2, A_3, \dots, A_n$  are n mutually independent events, then

$$P(A_1 \cap A_2 \cap \dots \cap A_n) = P(A_1).P(A_2) \dots P(A_n)$$

#### Theorem:

**If A and B are independent events then**

**a) A and B' are also independent event**

**b) A' and B' are also independent event**

**Proof:** Since A and B are independent, therefore  $P(A \cap B) = P(A).P(B) \dots (1)$

$$\begin{aligned} \text{a) } P(A \cap B') &= P(A) - P(A \cap B) \\ &= P(A) - P(A).P(B) \text{ [From (1)]} \end{aligned}$$

$$= P(A)\{1 - P(B)\}$$

$$= P(A).P(B')$$

∴ A and B' are also independent.

$$\text{b) } P(A' \cap B') = P(A \cup B)'$$

(By De Morgan's Law)

$$= 1 - P(A \cup B)$$

$$= 1 - [P(A) + P(B) - P(A \cap B)]$$

$$= 1 - P(A) - P(B) + P(A).P(B) \text{ from (I)}$$

$$= [1 - P(A)] - P(B)[1 - P(A)]$$

$$= [1 - P(A)] [1 - P(B)]$$

$$= P(A').P(B')$$

∴ A' and B' are also independent.

### SOLVED EXAMPLES

**Ex. 1:** Two cards are drawn at random one after the other. Given that first card drawn is non-face red card, what is the probability that second card is face card, if the cards are drawn

i) without replacement? ii) with replacement?

**Solution :** Let event A: first card drawn is a non-face red card and event B: second card drawn is face card.

$$\therefore P(A) = \frac{20}{52} = \frac{5}{13} \text{ and } P(B) = \frac{12}{52} = \frac{3}{13}$$

∴ required probability = P(second card drawn is face card given that it is a red card)

i) Without replacement: Since first non-face red card is not replaced, therefore now we have 51 cards containing 12 face cards.

$$\therefore P(B/A) = \frac{12}{51} \neq P(B). \text{ In this case A and B}$$

are not independent.

ii) With replacement: Since first non-face red card is replaced, therefore now again we have 52 cards containing 12 face cards.

$$\therefore P(B/A) = \frac{12}{52} = \frac{3}{13} = P(B).$$

In this case A and B are independent.

**Ex.2:** If A and B are two independent events and  $P(A) = \frac{3}{5}$ ,  $P(B) = \frac{2}{3}$ , find

- i)  $P(A \cap B)$  ii)  $P(A \cap B')$  iii)  $P(A' \cap B)$   
iv)  $P(A' \cap B')$  v)  $P(A \cup B)$

**Solution :**  $P(A) = \frac{3}{5} \therefore P(A') = 1 - P(A) = \frac{2}{5}$

$P(B) = \frac{2}{3} \therefore P(B') = 1 - P(B) = \frac{1}{3}$

i)  $P(A \cap B) = P(A)P(B) = \frac{2}{5}$

ii)  $P(A \cap B') = P(A)P(B') = \frac{1}{5}$

iii)  $P(A' \cap B) = P(A')P(B) = \frac{4}{15}$

iv)  $P(A' \cap B') = P(A')P(B') = \frac{2}{15}$

v)  $P(A \cup B) = P(A) + P(B) - P(A \cap B) = \frac{13}{15}$

**Ex. 3)** Three professors A, B and C appear in an interview for the post of Principal. Their chances of getting selected as a principal are  $\frac{2}{9}$ ,  $\frac{4}{9}$ ,  $\frac{1}{3}$ . The probabilities they introduce new course in the college are  $\frac{3}{10}$ ,  $\frac{1}{2}$ ,  $\frac{4}{5}$  respectively. Find the probability that the new course is introduced.

**Solution :** Let A, B, C be the events that prof. A, B and C are selected as principal.

Given  $P(A) = \frac{2}{9}$ ,  $P(B) = \frac{4}{9}$ ,  $P(C) = \frac{1}{3} = \frac{3}{9}$

Let N be the event that New Course in introduced  $P(N/A) = \square$ ,  $P(N/B) = \square$ ,

$P(N/C) = \frac{4}{5}$

$N = (A \cap N) \cup (B \cap \square) \cup (\square \cap N)$

$\therefore P(N) = P(A \cap N) + P(B \cap \square) + P(\square \cap N)$

$= P(A).P(N/A) + P(\square) \times \square$

$+ \square \times P(N/C)$

$= \square \square + \square \square + \square \square$

$= \square + \square + \square = \square$

**EXERCISE 9.3**

- 1) A bag contains 3 red marbles and 4 blue marbles. Two marbles are drawn at random without replacement. If the first marble drawn is red, what is the probability the second marble is blue?
- 2) A box contains 5 green pencils and 7 yellow pencils. Two pencils are chosen at random from the box without replacement. What is the probability that both are yellow?
- 3) In a sample of 40 vehicles, 18 are red, 6 are trucks, of which 2 are red. Suppose that a randomly selected vehicle is red. What is the probability it is a truck?
- 4) From a pack of well-shuffled cards, two cards are drawn at random. Find the probability that both the cards are diamonds when
  - i) first card drawn is kept aside
  - ii) the first card drawn is replaced in the pack.
- 5) A, B, and C try to hit a target simultaneously but independently. Their respective probabilities of hitting the target are  $\frac{3}{4}$ ,  $\frac{1}{2}$  and  $\frac{5}{8}$ . Find the probability that the target
  - a) is hit exactly by one of them
  - b) is not hit by any one of them
  - c) is hit
  - d) is exactly hit by two of them

- 6) The probability that a student X solves a problem in dynamics is  $\frac{2}{5}$  and the probability that student Y solves the same problem is  $\frac{1}{4}$ . What is the probability that
- the problem is not solved
  - the problem is solved
  - the problem is solved exactly by one of them
- 7) A speaks truth in 80% of the cases and B speaks truth in 60% of the cases. Find the probability that they contradict each other in narrating an incident.
- 8) Two hundred patients who had either Eye surgery or Throat surgery were asked whether they were satisfied or unsatisfied regarding the result of their surgery.

The following table summarizes their response.

Surgery	Satisfied	Unsatisfied	Total
Throat	70	25	95
Eye	90	15	105
Total	160	40	200

If one person from the 200 patients is selected at random, determine the probability

- that the person was satisfied given that the person had Throat surgery
  - that person was unsatisfied given that the person had eye surgery
  - the person had Throat surgery given that the person was unsatisfied
- 9) Two dice are thrown together. Let A be the event 'getting 6 on the first die' and B be the event 'getting 2 on the second die'. Are the events A and B independent?
- 10) The probability that a man who is 45 years old will be alive till he becomes 70 is  $\frac{5}{12}$ .

The probability that his wife who is 40 years old will be alive till she becomes 65 is  $\frac{3}{8}$ .

What is the probability that, 25 years hence,

- the couple will be alive
  - exactly one of them will be alive
  - none of them will be alive
  - at least one of them will be alive
- 11) A box contains 10 red balls and 15 green balls. Two balls are drawn in succession without replacement. What is the probability that,
- the first is red and the second is green?
  - one is red and the other is green?
- 12) A bag contains 3 yellow and 5 brown balls. Another bag contains 4 yellow and 6 brown balls. If one ball is drawn from each bag, what is the probability that,
- both the balls are of the same color?
  - the balls are of different color?
- 13) An urn contains 4 black, 5 white and 6 red balls. Two balls are drawn one after the other without replacement. What is the probability that at least one of them is black?
- 14) Three fair coins are tossed. What is the probability of getting three heads given that at least two coins show heads?
- 15) Two cards are drawn one after the other from a pack of 52 cards without replacement. What is the probability that both the cards drawn are face cards?
- 16) Bag A contains 3 red and 2 white balls and bag B contains 2 red and 5 white balls. A bag is selected at random, a ball is drawn and put into the other bag, and then a ball is drawn from that bag. Find the probability that both the balls drawn are of same color.
- 17) (Activity) : A bag contains 3 red and 5 white balls. Two balls are drawn at random one after the other without replacement. Find the probability that both the balls are white.

**Solution :** Let,

A : First ball drawn is white

B : second ball drawn in white.

$$P(A) = \frac{\square}{\square}$$

After drawing the first ball, without replacing it into the bag a second ball is drawn from the remaining  $\square$  balls.

$$\therefore P(B/A) = \frac{\square}{\square}$$

$$\begin{aligned} \therefore P(\text{Both balls are white}) &= P(A \cap B) \\ &= P(\square) \cdot P(\square) \\ &= \square \square \\ &= \square \end{aligned}$$

18) A family has two children. Find the probability that both the children are girls, given that atleast one of them is a girl.

### 9.4 Bayes' Theorem:

(This is also known as Bayes' Law and sometimes Bayes' Rule). This is a direct application of conditional probabilities. Bayes' theorem is useful, to determine posterior probabilities.

**Theorem :** If  $E_1, E_2, E_3 \dots E_n$  are mutually exclusive and exhaustive events with  $P(E_i) \neq 0$ , where  $i = 1, 2, 3 \dots n$  then for any arbitrary event  $A$  which is a subset of the union of events  $E_i$  such that  $P(A) > 0$ , we have

$$P(E_i/A) = \frac{P(A \cap E_i)}{P(A)} = \frac{P(E_i) \cdot P(A/E_i)}{\sum_{i=1}^n P(A \cap E_i)}$$

**Proof :** We have  $A = (A \cap E_1) \cup (A \cap E_2) \cup (A \cap E_3) \dots \cup (A \cap E_n)$

$A \cap E_1, A \cap E_2, A \cap E_3 \dots A \cap E_n$  are mutually exclusive events

So,  $P(A) = P[(A \cap E_1) \cup (A \cap E_2) \cup (A \cap E_3) \dots \cup (A \cap E_n)]$

$$P(A) = \sum_{i=1}^n P(A \cap E_i)$$

Also,  $P(A \cap E_i) = P(A) \cdot P(E_i/A)$

$$\text{i.e. } P(E_i/A) = \frac{P(A \cap E_i)}{P(A)} = \frac{P(E_i) \cdot P(A/E_i)}{\sum_{i=1}^n P(A \cap E_i)}$$

Three types of probabilities occur in the above formula  $P(E_i), P(A/E_i), P(E_i/A)$

- i) The probabilities occur in the above formula  $P(E_i), i = 1, 2, 3, \dots n$  are such that  $P(E_1) + P(E_2) + \dots + P(E_n) = 1$  are called prior probabilities, since they are known before conducting experiment.
- ii) The probabilities  $P(A/E_i)$  tell us, how likely the event  $A$  under consideration occurs, given each and every prior probability. They may refer to as likelihood probabilities of the event  $A$ , given that event  $E_i$  has already occurred.
- iii) The conditional probabilities  $P(E_i/A)$  are called posterior probabilities, as they obtained after conducting experiment.

Bayes' theorem for  $n = 3$  is explained in the following figure.

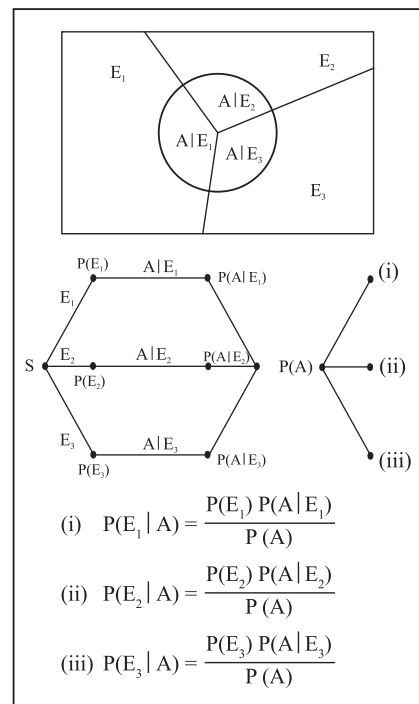

**Fig. 9.2 (a) & (b)**

**SOLVED EXAMPLES**

**Ex. 1:** A bag contains 6 red, 5 blue balls and another bag contains 5 red and 8 blue balls. A ball is drawn from first bag and without noticing colour is put in the second bag. A ball is drawn from the second bag. Find the probability that ball drawn is blue in colour.

**Solution:** Let event  $E_1$ : Red ball is drawn from the first bag and event  $E_2$ : Blue ball is drawn from the first bag.

$\therefore P(E_1) = 6/11$  and  $P(E_2) = \frac{5}{11}$  (Note that  $E_1$  and  $E_2$  are mutually exclusive and exhaustive events)

Let event A: Blue ball is drawn from the second bag

$\therefore P(A/E_1) = P(\text{Blue ball is drawn from the second under the condition that red ball is transferred from first bag to second bag}) = \frac{8}{14}$

Similarly,  $P(A/E_2) = P(\text{Blue ball is drawn from the second under the condition that blue ball is transferred from first bag to second bag}) = \frac{9}{14}$

$\therefore$  required probability =  $P(\text{Blue ball is drawn from the second bag})$

$$\begin{aligned} \therefore P(A) &= P(A \cap E_1) + P(A \cap E_2) \\ &= P(E_1)P(A/E_1) + P(E_2)P(A/E_2) \\ &= \left(\frac{6}{11}\right)\left(\frac{8}{14}\right) + \left(\frac{5}{11}\right)\left(\frac{9}{14}\right) \\ &= \left(\frac{48}{154}\right)\left(\frac{45}{154}\right) = \frac{93}{154} \end{aligned}$$

**Ex. 2:** The chances of X, Y, Z becoming managers of a certain company are 4:2:3. The probabilities that the bonus scheme will be introduced if X, Y, Z become managers are 0.3,

0.5 and 0.8 respectively. If the bonus scheme has been introduced, what is the probability that X is appointed as the manger?

**Solution:** Let  $E_1$ : Person X becomes manager

$E_2$ : Person Y becomes manager

Let  $E_3$ : Person Z becomes manager

$$\therefore P(E_1) = \frac{4}{9}; P(E_2) = \frac{2}{9}; P(E_3) = \frac{3}{9}$$

(Note that  $E_1, E_2$  and  $E_3$  are mutually exclusive and exhaustive events)

Let event A: Bonus is introduced.

$\therefore P(A/E_1) = P(\text{Bonus is introduced under the condition that person X becomes manager}) = 0.3$

$P(A/E_2) = P(\text{Bonus is introduced under the condition that person Y becomes manager}) = 0.5$

and  $P(A/E_3) = P(\text{Bonus is introduced under the condition that person Z becomes manager}) = 0.8$

$$\begin{aligned} \therefore P(A) &= P(A \cap E_1) + P(A \cap E_2) + P(A \cap E_3) \\ &= P(E_1)P(A/E_1) + P(E_2)P(A/E_2) + P(E_3)P(A/E_3) \end{aligned}$$

$$\begin{aligned} &= \left(\frac{4}{9}\right)(0.3) + \left(\frac{2}{9}\right)(0.5) + \left(\frac{3}{9}\right)(0.8) \\ &= \frac{23}{45} \end{aligned}$$

$\therefore$  required probability =  $P(\text{Person X becomes manager under the condition that bonus scheme is introduced})$

$$\begin{aligned} &= P(E_1/A) = P(A \cap E_1) / P(A) \\ &= \frac{(2/15)}{(23/45)} \\ &= \frac{6}{23} \end{aligned}$$

**Ex. 3:** The members of the consulting firm hire cars from three rental agencies, 60% from agency X, 30% from agency Y and 10% from agency Z. 9% of the cars from agency X need

repairs, 20% of the cars from agency Y need repairs and 6% of the cars from agency Z need repairs. If a rental car delivered to the consulting firms needs repairs, what is the probability that it came from rental agency Y?

**Solution :** If A is the event that the car needs repairs and B, C, D are the events that the car comes from rental agencies X, Y or Z. We have  $P(B) = 0.6$ ,  $P(C) = 0.3$ ,  $P(D) = 0.1$ ,  $P(A/B) = 0.09$ ,  $P(A/C) = 0.2$  and  $P(A/D) = 0.06$

$$\begin{aligned} P(A) &= P(A \cap B) + P(A \cap C) + P(A \cap D) \\ &= P(B).P(A/B) + P(C).P(A/C) + \\ &P(D).P(A/D) \\ &= 0.6 \times 0.09 + 0.3 \times 0.2 + 0.1 \times 0.06 \\ &= 0.054 + 0.06 + 0.006 \end{aligned}$$

$$\therefore P(A) = 0.12$$

$$P(C/A) = \frac{P(A \cap C)}{P(A)} = \frac{P(C).P(A/C)}{P(A)}$$

$$= \frac{0.3 \times 0.2}{0.12} = \frac{0.06}{0.12}$$

$$= 0.5$$

#### EXERCISE 9.4

- 1) There are three bags, each containing 100 marbles. Bag 1 has 75 red and 25 blue marbles. Bag 2 has 60 red and 40 blue marbles and Bag 3 has 45 red and 55 blue marbles. One of the bags is chosen at random and a marble is picked from the chosen bag. What is the probability that the chosen marble is red?
- 2) A box contains 2 blue and 3 pink balls and another box contains 4 blue and 5 pink balls. One ball is drawn at random from one of the two boxes and it is found to be pink. Find the probability that it was drawn from (i) first box (ii) second box.
- 3) There is a working women's hostel in a town, where 75% are from neighbouring town. The rest all are from the same town. 48% of women who hail from the same town are graduates and 83% of the women who have come from the neighboring town are also graduates. Find the probability that a woman selected at random is a graduate from the same town.
- 4) If  $E_1$  and  $E_2$  are equally likely, mutually exclusive and exhaustive events and  $P(A/E_1) = 0.2$ ,  $P(A/E_2) = 0.3$ . Find  $P(E_1/A)$ .
- 5) Jar I contains 5 white and 7 black balls. Jar II contains 3 white and 12 black balls. A fair coin is flipped; if it is Head, a ball is drawn from Jar I, and if it is Tail, a ball is drawn from Jar II. Suppose that this experiment is done and a white ball was drawn. What is the probability that this ball was in fact taken from Jar II?
- 6) A diagnostic test has a probability 0.95 of giving a positive result when applied to a person suffering from a certain disease, and a probability 0.10 of giving a (false) positive result when applied to a non-sufferer. It is estimated that 0.5% of the population are sufferers. Suppose that the test is now administered to a person about whom we have no relevant information relating to the disease (apart from the fact that he/she comes from this population). Calculate the probability that:
  - a) given a positive result, the person is a sufferer.
  - b) given a negative result, the person is a non-sufferer.
- 7) A doctor is called to see a sick child. The doctor has prior information that 80% of the sick children in that area have the flu, while the other 20% are sick with measles. Assume that there is no other disease in that area. A well-known symptom of measles is rash. From the past records, it is known

that, chances of having rashes given that sick child is suffering from measles is 0.95. However occasionally children with flu also develop rash, whose chance are 0.08. Upon examining the child, the doctor finds a rash. What is the probability that child is suffering from measles?

- 8) 2% of the population have a certain blood disease of a serious form: 10% have it in a mild form; and 88% don't have it at all. A new blood test is developed; the probability of testing positive is  $\frac{9}{10}$  if the subject has the serious form,  $\frac{6}{10}$  if the subject has the mild form, and  $\frac{1}{10}$  if the subject doesn't have the disease. A subject is tested positive. What is the probability that the subject has serious form of the disease?
- 9) A box contains three coins: two fair coins and one fake two-headed coin is picked randomly from the box and tossed.
- What is the probability that it lands head up?
  - If happens to be head, what is the probability that it is the two-headed coin?
- 10) There are three social media groups on a mobile: Group I, Group II and Group III. The probabilities that Group I, Group II and Group III sending the messages on sports are  $\frac{2}{5}$ ,  $\frac{1}{2}$ , and  $\frac{2}{3}$  respectively. The probability of opening the messages by Group I, Group II and Group III are  $\frac{1}{2}$ ,  $\frac{1}{4}$  and  $\frac{1}{4}$  respectively. Randomly one of the messages is opened and found a message on sports. What is the probability that the message was from Group III.
- 11) (Activity): Mr. X goes to office by Auto, Car and train. The probabilities him travelling by these modes are  $\frac{2}{7}$ ,  $\frac{3}{7}$ ,  $\frac{2}{7}$  respectively. The

chances of him being late to the office are  $\frac{1}{2}$ ,  $\frac{1}{4}$ ,  $\frac{1}{4}$  respectively by Auto, Car and train. On one particular day he was late to the office. Find the probability that he travelled by car.

**Solution :** Let A, C and T be the events that Mr. X goes to office by Auto, Car and Train respectively. Let L be event that he is late.

Given that  $P(A) = \square$ ,  $P(B) = \square$ ,

$P(C) = \square$

$P(L/A) = \frac{1}{2}$ ,  $P(L/B) = \square$ ,  $P(L/C) = \frac{1}{4}$

$P(L) = P(A \cap L) + P(C \cap L) + P(T \cap L)$

$= P(A).P(L/A) + P(C).P(L/C) + P(T).P(L/T)$

$= \square \square + \square \square + \square \square$

$= \square + \square + \square$

$= \square$

$P(L/C) = \frac{P(A \cap C)}{P(L)} = \frac{P(C).P(L/C)}{P(L)}$

$= \frac{\square \square}{\square}$

$= \square$

### 9.5 ODDS (Ratio of two complementary probabilities):

Let n be number of distinct sample points in the sample space S. Out of n sample points, m sample points are favourable for the occurrence of event A. Therefore remaining (n-m) sample points are favourable for the occurrence of its complementary event A'.

$$\therefore P(A) = \frac{m}{n} \text{ and } P(A') = \frac{n-m}{n}$$

Ratio of number of favourable cases to number of unfavourable cases is called as odds in favour of event A which is given by  $\frac{m}{n-m}$  i.e.  $P(A):P(A')$

Ratio of number of unfavourable cases to number of favourable cases is called as odds against event A which is given by  $\frac{n-m}{m}$  i.e.  $P(A'):P(A)$

**SOLVED EXAMPLES**

**Ex. 1:** A fair die is thrown. What are the odds in favour of getting a number which is a perfect square in uppermost face of die?

**Soln.:** Random experiment: A fair die is thrown.

∴ Sample space  $S = \{1, 2, 3, 4, 5, 6\}$

∴  $n(S) = 6$

Let event A: die shows number which is a perfect square.

∴  $A = \{1, 4\}$  ∴  $m = n(A) = 2$

∴  $A' = \{2, 3, 5, 6\}$  ∴  $(n - m) = 4$ .

∴  $P(A) = \frac{m}{n} = \frac{2}{6} = \frac{1}{3}$

$P(A') = \frac{n-m}{n} = \frac{4}{6} = \frac{2}{3}$

∴ Odds in favour of event

$A = P(A) : P(A') = \frac{1/3}{2/3} = \frac{1}{2}$

**Ex. 2:** The probability of one event A happening is the square of the probability of second event B, but the odds against the event A are the cube of the odds against the event B. Find the probability of each event.

**Solution :** Let  $P(A) = p_1$  and  $P(B) = p_2$ .

∴ probability on non-occurrence of the events A and B are  $(1-p_1)$  and  $(1-p_2)$  respectively. We are given that  $p_1 = (p_2)^2$  .... (I)

Odds against the event A =  $\frac{1-p_1}{p_1}$

Odds against the event B =  $\frac{1-p_2}{p_2}$

Since odds against the event A are the cube of the odds against the event B.

$\frac{1-p_1}{p_1} = \left(\frac{1-p_2}{p_2}\right)^3$

$\frac{1-p_2^2}{p_2^2} = \frac{(1-p_2)^3}{p_2^3}$  [By (I)]

$\frac{(1-p_2)(1+p_2)}{1} = \frac{(1-p_2)^3}{p_2}$

∴  $p_2(1+p_2) = 1-2p_2+p_2^2$

$p_2+p_2^2 = 1-2p_2+p_2^2$

$3p_2 = 1$

∴  $p_2 = \frac{1}{3}$

$p_1 = (p_2)^2 = \left(\frac{1}{3}\right)^2 = \frac{1}{9}$

∴  $P(A) = \frac{1}{9}$  and  $P(B) = \frac{1}{3}$

**EXERCISE 9.5**

- 1) If odds in favour of X solving a problem are 4:3 and odds against Y solving the same problem are 2:3. Find probability of:
  - i) X solving the problem
  - ii) Y solving the problem
- 2) The odds against John solving a problem are 4 to 3 and the odds in favor of Rafi solving the same problem are 7 to 5. What is the chance that the problem is solved when both them try it?
- 3) The odds against student X solving a statistics problem are 8:6 and odds in favour of student y solving the same problem are 14:16. Find is the chance that
  - i) the problem will be solved if they try it independently
  - ii) neither of them solves the problem
- 4) The odds against a husband who is 60 years old, living till he is 85 are 7:5. The odds against his wife who is now 56, living till she is 81 are 5:3. Find the probability that
  - a) at least one of them will be alive 25 years hence
  - b) exactly one of them will be alive 25 years hence.

- 5) There are three events A, B and C, one of which must, and only one can happen. The odds against the event A are 7:4 and odds against event B are 5:3. Find the odds against event C.
- 6) In a single toss of a fair die, what are the odds against the event that number 3 or 4 turns up?
- 7) The odds in favour of A winning a game of chess against B are 3:2. If three games are to be played, what are the odds in favour of A's winning at least two games out of the three?



### Let's Remember

A.N. Kolmogorov, a Russian mathematician outlined an axiomatic definition of probability that formed the basis of the modern theory. For every event A of sample space S, we assign a non-negative real number denoted by P(A) and is called probability of A, which satisfied following three axioms

- 1)  $0 \leq P(A) \leq 1$
- 2)  $P(S) = 1$

If A and B are mutually exclusive events, then  $P(A \cup B) = P(A) + P(B)$

### Addition theorem:

If A and B are any two events defined on the same sample space S, then probability of occurrence of at least one event is denoted by  $P(A \cup B)$  and is given by  $P(A \cup B) = P(A) + P(B) - P(A \cap B)$

### Conditional probability:

If A and B are any two events defined on the same sample space S, then conditional probability of event A given that event B has already occurred is denoted by  $P(A/B)$

$$\therefore P(A/B) = P(A \cap B) / P(B), P(B) \neq 0$$

$$\text{Similarly, } P(B/A) = P(A \cap B) / P(A), P(A) \neq 0$$

### Multiplication theorem:

If A and B are any two events defined on the same sample space S, then probability of simultaneous occurrence of both events is denoted by  $P(A \cap B)$  and is given by  $P(A \cap B) = P(A)P(B/A)$

### Independent events:

If the occurrence of any one event does not depend on occurrence of other event, then two events A and B are said to be independent.

$$\text{i.e. if } P(A/B) = P(A/B') = P(A)$$

$$\text{or } P(B/A) = P(B/A') = P(B)$$

then A and B are independent events.

$$\therefore P(A \cap B) = P(A)P(B)$$

If A and B are independent events then

- a) A and B' are also independent events
- b) A' and B are also independent events.

### Bayes' Theorem :

If  $E_1, E_2, E_3 \dots E_n$  are mutually exclusive and exhaustive events with  $P(E_i) \neq 0$ , where  $i = 1, 2, 3 \dots n$ . then for any arbitrary event A which is a subset of the union of events E such that  $P(A) > 0$ , we have

$$P(E_i/A) = \frac{P(A \cap E_i)}{P(A)} = \frac{P(E_i) \cdot P(A/E_i)}{\sum_{i=1}^n P(A \cap E_i)}$$

### MISCELLANEOUS EXERCISE - 9

#### I) Select the correct answer from the given four alternatives.

- 1) There are 5 girls and 2 boys, then the probability that no two boys are sitting together for a photograph is  
A)  $\frac{1}{21}$     B)  $\frac{4}{7}$     C)  $\frac{2}{7}$     D)  $\frac{5}{7}$
- 2) In a jar there are 5 black marbles and 3 green marbles. Two marbles are picked randomly one after the other without replacement.

- What is the possibility that both the marbles are black?  
A)  $\frac{5}{14}$    B)  $\frac{5}{8}$    C)  $\frac{5}{8}$    D)  $\frac{5}{16}$
- 3) Two dice are thrown simultaneously. Then the probability of getting two numbers whose product is even is  
A)  $\frac{3}{4}$    B)  $\frac{1}{4}$    C)  $\frac{5}{7}$    D)  $\frac{1}{2}$
- 4) In a set of 30 shirts, 17 are white and rest are black. 4 white and 5 black shirts are tagged as 'PARTY WEAR'. If a shirt is chosen at random from this set, the possibility of choosing a black shirt or a 'PARTY WEAR' shirt is  
A)  $\frac{11}{15}$    B)  $\frac{13}{30}$    C)  $\frac{9}{13}$    D)  $\frac{17}{30}$
- 5) There are 2 shelves. One shelf has 5 Physics and 3 Biology books and the other has 4 Physics and 2 Biology books. The probability of drawing a Physics book is  
A)  $\frac{9}{14}$    B)  $\frac{31}{48}$    C)  $\frac{9}{38}$    D)  $\frac{1}{2}$
- 6) Two friends A and B apply for a job in the same company. The chances of A getting selected is  $\frac{2}{5}$  and that of B is  $\frac{4}{7}$ . The probability that both of them get selected is  
A)  $\frac{34}{35}$    B)  $\frac{1}{35}$    C)  $\frac{8}{35}$    D)  $\frac{27}{35}$
- 7) The probability that a student knows the correct answer to a multiple choice question is  $\frac{2}{3}$ . If the student does not know the answer, then the student guesses the answer. The probability of the guessed answer being correct is  $\frac{1}{4}$ . Given that the student has answered the question correctly, the probability that the student knows the correct answer is  
A)  $\frac{5}{6}$    B)  $\frac{6}{7}$    C)  $\frac{7}{8}$    D)  $\frac{8}{9}$
- 8) Bag I contains 3 red and 4 black balls while another Bag II contains 5 red and 6 black balls. One ball is drawn at random from one of the bags and it is found to be red. The probability that it was drawn from Bag II.  
A)  $\frac{33}{68}$    B)  $\frac{35}{69}$    C)  $\frac{34}{67}$    D)  $\frac{35}{68}$
- 9) A fair is tossed twice. What are the odds in favour of getting 4, 5 or 6 on the first toss and 1, 2, 3 or 4 on the second die?  
A) 1 : 3   B) 3 : 1   C) 1 : 2   D) 2 : 1
- 10) The odds against an event are 5:3 and the odds in favour of another independent event are 7:5. The probability that at least one of the two events will occur is  
A)  $\frac{52}{96}$    B)  $\frac{71}{96}$    C)  $\frac{69}{96}$    D)  $\frac{13}{96}$
- II) Solve the following.**
- 1) The letters of the word 'EQUATION' are arranged in a row. Find the probability that a) All the vowels are together b) Arrangement starts with a vowel and ends with a consonant.
- 2) There are 6 positive and 8 negative numbers. Four numbers are chosen at random, without replacement, and multiplied. Find the probability that the product is a positive number.
- 3) Ten cards numbered 1 to 10 are placed in a box, mixed up thoroughly and then one card is drawn randomly. If it is known that the number on the drawn card is more than 3, what is the probability that it is an even number?
- 4) If  $P(A \cap B) = \frac{1}{2}$ ,  $P(B \cap C) = \frac{1}{3}$ ,  $P(C \cap A) = \frac{1}{6}$  then find  $P(A)$ ,  $P(B)$  and  $P(C)$ .
- 5) If the letters of the word 'REGULATIONS' be arranged at random, what is the probability that there will be exactly 4 letters between R and E?

- 6) In how many ways can the letters of the word ARRANGEMENTS be arranged?
- Find the chance that an arrangement chosen at random begins with the letters EE.
  - Find the probability that the consonants are together.
- 7) A letter is taken at random from the letters of the word 'ASSISTANT' and another letter is taken at random from the letters of the word 'STATISTICS'. Find probability that the selected letters are the same.
- 8) A die is loaded in such a way that the probability of the face with  $j$  dots turning up is proportional to  $j$  for  $j = 1, 2, \dots, 6$ . What is the probability, in one roll of the die, that an odd number of dots will turn up?
- 9) An urn contains 5 red balls and 2 green balls. A ball is drawn. If it's green a red ball is added to the urn and if it's red a green ball is added to the urn. (The original ball is not returned to the urn). Then a second ball is drawn. What is the probability the second ball is red?
- 10) The odds against A solving a certain problem are 4 to 3 and the odds in favor of solving the same problem are 7 to 5 find the probability that the problem will be solved.
- 11) If  $P(A) = P\left(\frac{A}{B}\right) = \frac{1}{5}$ ,  $P\left(\frac{B}{A}\right) = \frac{1}{3}$  then find
- $P\left(\frac{A'}{B}\right)$
  - $P\left(\frac{B'}{A}\right)$
- 12) Let A and B be independent events with  $P(A) = \frac{1}{4}$ , and  $P(A \cup B) = 2P(B) - P(A)$ . Find a)  $P(B)$ ; b)  $P(A/B)$ ; and c)  $P(B'/A)$ .
- 13) Find the probability that a year selected will have 53 Wednesdays.
- 14) The chances of P, Q and R, getting selected as principal of a college are  $\frac{2}{5}$ ,  $\frac{2}{5}$ ,  $\frac{1}{5}$  respectively. Their chances of introducing IT in the college are  $\frac{1}{2}$ ,  $\frac{1}{3}$ ,  $\frac{1}{4}$  respectively. Find the probability that
- IT is introduced in the college after one of them is selected as a principal .
  - IT is introduced by Q.
- 15) Suppose that five good fuses and two defective ones have been mixed up. To find the defective fuses, we test them one-by-one, at random and without replacement. What is the probability that we are lucky and find both of the defective fuses in the first two tests?
- 16) For three events A, B and C, we know that A and C are independent, B and C are independent, A and B are disjoint,  $P(A \cup C) = \frac{2}{3}$ ,  $P(B \cup C) = \frac{3}{4}$ ,  $P(A \cup B \cup C) = \frac{11}{12}$ . Find  $P(A)$ ,  $P(B)$  and  $P(C)$ .
- 17) The ratio of Boys to Girls in a college is 3:2 and 3 girls out of 500 and 2 boys out of 50 of that college are good singers. A good singer is chosen what is the probability that the chosen singer is a girl?
- 18) A and B throw a die alternatively till one of them gets a 3 and wins the game. Find the respective probabilities of winning. (Assuming A begins the game).
- 19) Consider independent trials consisting of rolling a pair of fair dice, over and over What is the probability that a sum of 5 appears before sum of 7?

- 20) A machine produces parts that are either good (90%), slightly defective (2%), or obviously defective (8%). Produced parts get passed through an automatic inspection machine, which is able to detect any part that is obviously defective and discard it. What is the quality of the parts that make it through the inspection machine and get shipped?
- 21) Given three identical boxes, I, II and III, each containing two coins. In box I, both coins are gold coins, in box II, both are silver coins and in the box III, there is one gold and one silver coin. A person chooses a box at random and takes out a coin. If the coin is of gold, what is the probability that the other coin in the box is also of gold?
- 22) In a factory which manufactures bulbs, machines A, B and C manufacture respectively 25%, 35% and 40% of the bulbs. Of their outputs, 5, 4 and 2 percent are respectively defective bulbs. A bulb is drawn at random from the product and is found to be defective. What is the probability that it is manufactured by the machine B?
- 23) A family has two children. One of them is chosen at random and found that the child is a girl. Find the probability that
- a) both the children are girls.
  - b) both the children are girls given that at least one of them is a girl.



## ANSWERS

### 1. ANGLE AND ITS MEASUREMENT

#### Exercise : 1.1

- 1) (A) (i), (iii), (iv), (vi) are co-terminal.  
(ii), (v) are non co-terminal.  
(B) (i) III (ii) III (iii) I (iv) I (v) III  
(vi) I (vii) IV (viii) I (ix) II (x) III
- 2) (i)  $\frac{17\pi}{36}$  (ii)  $\frac{25\pi}{18}$  (iii)  $\frac{11\pi}{15}$  (iv)  $\frac{131\pi}{360}$   
(v)  $\frac{151\pi}{360}$  (vi)  $\frac{51\pi}{225}$
- 3) (i)  $105^\circ$  (ii)  $-300^\circ$  (iii)  $\left(\frac{900}{\pi}\right)^0$   
(iv)  $110^\circ$  (v)  $\left(\frac{-45}{\pi}\right)^0$  or  $14^\circ 19'$  approx"
- 4) (i)  $183^\circ 42'$  (ii)  $245^\circ 19' 48''$  (iii)  $11^\circ 27' 33''$
- 5)  $25^\circ, \frac{5\pi}{36}$
- 6)  $30^\circ, \frac{\pi}{6}$
- 7)  $40^\circ, 50^\circ$  and  $90^\circ$  that is  $\frac{2\pi}{9}, \frac{5\pi}{18}$  and  $\frac{\pi}{2}$
- 8)  $420^\circ$  and  $480^\circ$
- 9)  $30^\circ, 70^\circ$  and  $80^\circ$  that is  $\frac{\pi}{6}, \frac{7\pi}{18}$  and  $\frac{4\pi}{9}$
- 10)  $20^\circ, 60^\circ$  and  $100^\circ$  that is  $\frac{\pi}{9}, \frac{\pi}{3}$  and  $\frac{5\pi}{9}$
- 11)  $40^\circ, 60^\circ, 140^\circ$  and  $120^\circ$
- 12)  $64^\circ, 96^\circ,$  and  $128^\circ$  that is  $\frac{16\pi}{45}, \frac{8\pi}{15}$  and  $\frac{32\pi}{45}$

- 13) (i)  $72^\circ$  or  $\frac{2\pi}{5}$  and  $108^\circ$  or  $\frac{3\pi}{5}$   
(ii)  $60^\circ$  or  $\frac{\pi}{3}$  and  $120^\circ$  or  $\frac{2\pi}{3}$   
(iii)  $(51.43)^\circ$  or  $\frac{2\pi}{7}$   
and  $(128.57)^\circ$  or  $\frac{5\pi}{7}$   
(iv)  $45^\circ$  or  $\frac{\pi}{4}$  and  $135^\circ$  or  $\frac{3\pi}{4}$
- 14) (i)  $85^\circ$  (ii)  $100^\circ$  (iii)  $162^\circ 30'$   
(iv)  $97^\circ 30'$  (v)  $50^\circ$  (vi)  $115^\circ$

#### Exercise : 1.2

- (1)  $9\pi$  cm (2)  $3\pi$  cm (3)  $\left(\frac{108}{\pi}\right)^0$  or  $(34.40)^\circ$   
approx (4) 4.4cm
- (5) 4 : 5 (6)  $4\pi$  cm and  $10\pi$  sqcm
- (7)  $18(\pi - 2\sqrt{2})$ sqcm (8)  $\frac{225}{4}\left(\frac{\pi}{3} - 1\right)$ sqcm
- (9) 25 sq cm (10) 160 sq cm

#### MISCELLANEOUS EXERCISE - 1

- (I) (i) B (ii) B (iii) A (iv) D (v) D (vi) C  
(vii) B (viii) B (ix) A (x) C.
- (II) (1) 8 (2)  $49\left(\frac{\pi}{2} - 1\right)$ sqcm (3)  $3\pi$  cm  
(4) 35.7 cm (5)  $\left(\frac{450}{\pi}\right)^0$  (6) 13:22

- (7)  $15\pi$  cm and  $\frac{135\pi}{2}$  sq cm      (9)  $17^\circ 11' 20''$       (11)  $60^\circ, 80^\circ, 100^\circ, 120^\circ$  that is  $\frac{\pi}{3}, \frac{4\pi}{9}, \frac{5\pi}{9}, \frac{2\pi}{3}$   
 (10)  $\frac{20\pi}{3}$

**2. TRIGONOMETRY - I**

**Exercise : 2.1**

(1)

$\theta$	$0^\circ$	$30^\circ$	$45^\circ$	$60^\circ$	$150^\circ$	$180^\circ$	$210^\circ$	$300^\circ$	$330^\circ$
$\sin\theta$	0	$\frac{1}{2}$	$\frac{1}{\sqrt{2}}$	$\frac{\sqrt{3}}{2}$	$\frac{1}{2}$	0	$\frac{1}{-2}$	$-\frac{\sqrt{3}}{2}$	$\frac{1}{-2}$
$\cos\theta$	1	$\frac{\sqrt{3}}{2}$	$\frac{1}{\sqrt{2}}$	$\frac{1}{2}$	$-\frac{\sqrt{3}}{2}$	-1	$-\frac{\sqrt{3}}{2}$	$\frac{1}{2}$	$\frac{\sqrt{3}}{2}$
$\tan\theta$	0	$\frac{1}{\sqrt{3}}$	1	$\sqrt{3}$	$-\frac{1}{\sqrt{3}}$	0	$\frac{1}{\sqrt{3}}$	$-\sqrt{3}$	$-\frac{1}{\sqrt{3}}$
$\operatorname{cosec}\theta$	N.D.	2	$\sqrt{2}$	$\frac{2}{\sqrt{3}}$	2	N.D.	-2	$-\frac{2}{\sqrt{3}}$	-2
$\sec\theta$	1	$\frac{2}{\sqrt{3}}$	$\sqrt{2}$	2	$-\frac{2}{\sqrt{3}}$	-1	$-\frac{2}{\sqrt{3}}$	2	$\frac{2}{\sqrt{3}}$
$\cot\theta$	N.D.	$\sqrt{3}$	1	$\frac{1}{\sqrt{3}}$	$-\sqrt{3}$	N.D.	$\sqrt{3}$	$-\frac{1}{\sqrt{3}}$	$-\sqrt{3}$

$\theta$	$-30^\circ$	$-45^\circ$	$-60^\circ$	$-90^\circ$	$-120^\circ$	$-225^\circ$	$-240^\circ$	$-270^\circ$	$-315^\circ$
$\sin\theta$	$-\frac{1}{2}$	$-\frac{1}{2}$	$-\frac{\sqrt{3}}{2}$	-1	$-\frac{\sqrt{3}}{2}$	$\frac{1}{\sqrt{2}}$	$\frac{\sqrt{3}}{2}$	1	$\frac{1}{\sqrt{2}}$
$\cos\theta$	$\frac{\sqrt{3}}{2}$	$\frac{1}{\sqrt{2}}$	$\frac{1}{2}$	0	$-\frac{1}{2}$	$-\frac{1}{\sqrt{2}}$	$-\frac{1}{2}$	0	$\frac{1}{\sqrt{2}}$
$\tan\theta$	$-\frac{1}{\sqrt{3}}$	-1	$-\sqrt{3}$	N.D.	$\sqrt{3}$	-1	$-\sqrt{3}$	N.D.	1
$\operatorname{cosec}$	-2	$-\sqrt{2}$	$-\frac{2}{\sqrt{3}}$	-1	$-\frac{2}{\sqrt{3}}$	$\sqrt{2}$	$\frac{2}{\sqrt{3}}$	1	$\sqrt{2}$
$\sec$	$\frac{2}{\sqrt{3}}$	$\sqrt{2}$	2	N.D.	-2	$-\sqrt{2}$	-2	N.D.	$\sqrt{2}$
$\cot$	$-\sqrt{3}$	-1	$-\frac{1}{\sqrt{3}}$	0	$\frac{1}{\sqrt{3}}$	-1	$-\frac{1}{\sqrt{3}}$	0	1

(2) (i) Positive (ii) Positive (iii) Negative

(3)  $\cos 4^\circ > \cos 4^c$ ,  $\cos 4^\circ > 0$ ,  $\cos 4^\circ < 0$

(4) (i) III (ii) III

(5) (i)  $\frac{1+\sqrt{2}}{2}$  (ii)  $1 + \sqrt{2}$  (iii) 0

(6)  $\sin \theta = -\frac{4}{5}$ ,  $\cos \theta = \frac{3}{5}$ ,  $\tan \theta = -\frac{4}{3}$ ,  
 $\operatorname{cosec} \theta = -\frac{5}{4}$ ,  $\sec \theta = \frac{5}{3}$ ,  $\cot \theta = -\frac{3}{4}$ ,

(7)  $-\frac{119}{120}$ ,  $\frac{144}{25}$

(8) (i)  $\frac{1}{2}$  (ii) 2

(9) (i)  $\sin \theta = -\frac{4}{5}$ ,  $\operatorname{cosec} \theta = -\frac{5}{4}$ ,  $\sec \theta = -\frac{5}{3}$

$\tan \theta = \frac{4}{3}$ ,  $\cot \theta = \frac{3}{4}$

(ii)  $\cos A = -\frac{7}{25}$ ,  $\sin A = \frac{24}{25}$ ,  $\tan A = -\frac{24}{7}$

$\operatorname{cosec} A = \frac{25}{24}$ ,  $\cot A = -\frac{7}{24}$

(iii)  $\sin x = -\frac{4}{5}$ ,  $\cos x = -\frac{3}{5}$ ,  $\operatorname{cosec} x = -\frac{5}{4}$

$\sec x = -\frac{5}{3}$ ,  $\tan x = \frac{4}{3}$

(iv)  $\sin x = -\frac{5}{13}$ ,  $\cos x = \frac{12}{13}$ ,

$\cot x = -\frac{12}{5}$ ,  $\operatorname{cosec} x = -\frac{13}{5}$ ,

$\sec x = \frac{13}{12}$

**Exercise : 2.2**

(1)  $\frac{2(1+\sqrt{3})}{\sqrt{3}(\sqrt{3}+\sqrt{2})}$  (2) -5 (3)  $\frac{8}{11}$

(4) (i)  $16x^2 - 9y^2 = 144$  (ii)  $16x^2 - 9y^2 = 576$   
 (iii)  $x^2 + y^2 = 41$

(iv)  $\left(\frac{x-5}{6}\right)^2 - \left(\frac{y-3}{8}\right)^2 = 1$

(v)  $\left(\frac{3y-5}{3}\right)^2 - \left(\frac{2x-3}{4}\right)^2 = 1$

(5)  $\cos \theta = \pm 1$  (6)  $\frac{1}{2}$  (7)  $30^\circ$  (8)  $60^\circ$

(9) 1 (10) -1 or  $\frac{13}{12}$  (11) -8

(12) (i) (0, 3) (ii) (-1, 0)

(13) (i)  $(5\sqrt{2}, 45^\circ)$  (ii) (2,  $60^\circ$ )

(iii)  $(\sqrt{2}, 225^\circ)$  (iv) (2,  $150^\circ$ )

(14) (i)  $\frac{\sqrt{3}}{2}$  (ii)  $\frac{1}{2}$  (iii)  $\frac{1}{\sqrt{3}}$

**MISCELLANEOUS EXERCISE - 2**

(I)

1	2	3	4	5	6	7	8	9	10
B	A	A	B	A	B	D	C	B	B

(II)

	90°	120°	225°	240°	270°	315°	-120°	-150°	-180°
sin	1	$\frac{\sqrt{3}}{2}$	$-\frac{1}{\sqrt{2}}$	$-\frac{\sqrt{3}}{2}$	-1	$-\frac{1}{\sqrt{2}}$	$-\frac{\sqrt{3}}{2}$	$-\frac{1}{2}$	0
cos	0	$-\frac{1}{2}$	$-\frac{1}{\sqrt{2}}$	$-\frac{1}{2}$	0	$\frac{1}{\sqrt{2}}$	$-\frac{1}{2}$	$-\frac{\sqrt{3}}{2}$	-1
tan	N.D.	$-\frac{1}{\sqrt{3}}$	1	$\sqrt{3}$	N.D.	-1	$\sqrt{3}$	$\frac{1}{\sqrt{3}}$	0
cosec	1	$\frac{2}{\sqrt{3}}$	$-\sqrt{2}$	$-\frac{2}{\sqrt{3}}$	-1	$-\sqrt{2}$	$-\frac{2}{\sqrt{3}}$	-2	N.D.
sec	N.D.	-2	$-\sqrt{2}$	-2	N.D.	$\sqrt{2}$	-2	$-\frac{2}{\sqrt{3}}$	-1
cot	0	$-\sqrt{3}$	1	$\frac{1}{\sqrt{3}}$	0	1	$\frac{1}{\sqrt{3}}$	$\sqrt{3}$	N.D.

-210°	-300°	-330°
$\frac{1}{2}$	$\frac{\sqrt{3}}{2}$	$\frac{1}{2}$
$-\frac{\sqrt{3}}{2}$	$\frac{1}{2}$	$\frac{\sqrt{3}}{2}$
$-\frac{1}{\sqrt{3}}$	$\sqrt{3}$	$\frac{1}{\sqrt{3}}$
2	$\frac{2}{\sqrt{3}}$	2
$-\frac{2}{\sqrt{3}}$	2	$\frac{2}{\sqrt{3}}$
$-\sqrt{3}$	c	$\sqrt{3}$

$$(8) \cos \theta = \frac{2xy}{x^2 + y^2}, \quad \tan \theta = \frac{x^2 - y^2}{2xy}$$

$$(9) -1$$

### 3. TRIGONOMETRY - II

#### Exercise : 3.1

$$Q.1 \text{ (i) } \frac{\sqrt{3}+1}{2\sqrt{2}} \quad \text{(ii) } \frac{\sqrt{3}-1}{2\sqrt{2}} \quad \text{(iii) } \frac{\sqrt{3}+1}{1-\sqrt{3}} \quad \text{(iv) } 1$$

$$Q.3 \text{ (i) } \frac{33}{65} \quad \text{(ii) } \frac{-16}{65} \quad \text{(iii) } \frac{-33}{56}$$

#### Exercise : 3.2

$$Q.1 \text{ (i) } -\frac{1}{2} \quad \text{(ii) } \frac{1}{\sqrt{2}} \quad \text{(iii) } \frac{1}{\sqrt{2}}$$

$$\text{(iv) } -\frac{1}{2} \quad \text{(v) } 1 \quad \text{(vi) } \frac{1}{\sqrt{3}}$$

(2) (i) Positive (ii) Negative (iii) Negative

(3) (i) IV (ii) III (iii) II

(4)  $\sin 1856 > \sin 2006$

(5)  $\sin(-310^\circ)$

(vii)  $-2$       (viii)  $-\sqrt{2}$       (ix)  $\frac{2}{\sqrt{3}}$

(x)  $-\sqrt{3}$

**Exercise : 3.3**

Q.1 (i)  $\sqrt{\frac{\sqrt{2}-1}{2\sqrt{2}}}$  OR  $\frac{\sqrt{2-\sqrt{2}}}{2}$

(ii)  $\sqrt{\frac{\sqrt{2}+1}{2\sqrt{2}}}$  OR  $\frac{\sqrt{2+\sqrt{2}}}{2}$

Q.2  $\frac{-120}{169}, \frac{-119}{169}, \frac{120}{119}$

**Exercise : 3.4**

Q.1 (i)  $\sin 6x + \sin 2x$       (ii)  $\sin \frac{7\pi}{12} + \sin \frac{\pi}{12}$

(iii)  $\cos 6\theta + \cos 2\theta$       (iv)  $\cos 110^\circ + \cos 40^\circ$

**MISCELLANEOUS EXERCISE - 3**

Q.1 (1) B    (2) C    (2) D    (4) C    (5) C  
(6) B    (7) C    (8) B    (9) A    (10) A

**4. DETERMINANTS AND MARTICES**

**Exercise : 4.1**

Q.1 (i)  $-2$       (ii)  $-10$       (iii)  $46$

(iv)  $abc + 2fgh - af^2 - bg^2 - ch^2$

Q.2 (i)  $x = 0, x = -1, x = 2$       (ii)  $x = -2$

Q.3  $x = 11,$        $y = 52 .$

Q.4  $M_{11} = 11, C_{11} = 11, M_{12} = 7, C_{12} = -7,$   
 $M_{13} = -3, C_{13} = -3$

$M_{21} = -23, C_{21} = 23, M_{22} = -11, C_{22} = -11,$   
 $M_{23} = 19, C_{23} = -19$

$M_{31} = -5, C_{31} = -5, M_{32} = -5, C_{32} = 5,$   
 $M_{33} = 5, C_{33} = 5$

Q.5  $-28$

Q.6  $-2$

**Exercise : 4.2**

Q.1 (i)  $0$       (ii)  $0$       (iii)  $0$

Q.5 (i)  $x = -\frac{7}{3}$       (ii)  $x = 1$  or  $2$  or  $3$ .

Q.6  $x = 0$  or  $12$

**Exercise : 4.3**

Q.1 (i)  $1, 2, 3$       (ii)  $-5, 3, 4$       (iii)  $2, 2, -1$

(iv)  $-\frac{1}{4}, \frac{1}{2}, 1.$

Q.2  $3, 5, 7$

Q.3 (1) Consistent    (ii) Not Consistent  
(iii) Consistent

Q.4 (i)  $16$       (ii)  $2$

Q.5 (i)  $16$  sq. unit      (ii)  $\frac{25}{8}$  sq. unit

(iii)  $10$  sq. unit

Q.6  $21$  sq. unit

Q.7  $1$  or  $-5$

Q.8 (i) Collinear      (ii) Non - Collinear  
(iii) Collinear

**MISCELLANEOUS EXERCISE - 4 (A)**

(I)

1	2	3	4	5	6	7	8	9	10
B	B	B	B	B	C	C	D	D	C

(II) Q.1 (i) -113 (ii) -76

Q.2 -2

Q.3 (i) 0 (ii) 0

Q.4 (i)  $M_{11} = 14, C_{11} = 14, M_{12} = -4, C_{12} = 4,$   
 $M_{13} = 8, C_{13} = 8$

$M_{21} = 16, C_{21} = -16, M_{22} = -2, C_{22} = -2,$   
 $M_{23} = 4, C_{23} = -4$

$M_{31} = -4, C_{31} = -4, M_{32} = 5, C_{32} = -5,$   
 $M_{33} = -1, C_{33} = -1$

(ii)  $M_{11} = 0, C_{11} = 0, M_{12} = 11, C_{12} = -11,$   
 $M_{13} = 0, C_{13} = 0$

$M_{21} = -3, C_{21} = 3, M_{22} = -1, C_{22} = 1, M_{23}$   
 $= 1, C_{23} = -1$

$M_{31} = 2, C_{31} = 2, M_{32} = -8, C_{32} = 8, M_{33} =$   
 $3, C_{33} = 3$

Q.5 (i)  $-\frac{1}{3}$  or 2 (ii)  $\frac{2}{3}$

Q.9 (i) 1, 2, 1 (ii) 1, 2, 3 (iii) 1, 2, -1

(iv)  $\frac{9}{2}, -\frac{3}{2}, \frac{1}{2}$

Q.10 (i)  $\frac{1}{3}$  (ii) 5 (iii) 5

Q.11 (i) 4 (ii)  $\frac{25}{2}$  (iii)  $\frac{13}{2}$

Q.12 (i) 0 or 16 (ii) -1 or -34

Q.13 32 sq. unit

Q.14 ₹1750, ₹1500, ₹1750

**Exercise : 4.4**

Q.1 (i)  $\begin{bmatrix} 0 & \frac{1}{4} \\ \frac{1}{2} & 0 \\ 2 & \frac{1}{2} \end{bmatrix}$  (ii)  $\begin{bmatrix} -2 & -5 \\ -1 & -4 \\ 0 & -3 \end{bmatrix}$  (iii)  $\frac{1}{5} \begin{bmatrix} 8 & 27 \\ 27 & 64 \\ 64 & 125 \end{bmatrix}$

Q.2 (i) Upper triangular matrix

(ii) Skew - symmetric matrix

(iii) Column matrix

(iv) row matrix

(v) scalar matrix

(vi) Lower triangular matrix

(vii) diagonal matrix

(viii) symmetric matrix

(ix) Identity matrix

(x) symmetric matrix

Q.3 (i) Singular (ii) Singular

(iii) Non-Singular (iv) Non-Singular

Q.4 (i)  $\frac{-6}{7}$  (ii) 6 (iii)  $\frac{49}{8}$

Q.5  $\begin{bmatrix} 5 & 1 & -1 \\ 3 & 2 & 0 \end{bmatrix}$

Q.6  $\begin{bmatrix} 7 & 3 & 1 \\ -2 & -4 & 1 \\ 5 & 9 & 1 \end{bmatrix}$

Q.7  $a = -4, b = \frac{3}{5}, c = -7$

Q.8  $x = -\frac{3}{2}, y = 5i, z = \sqrt{2}$

Q.9 (i) Symmetric

(ii) Neither Symmetric nor Skew Symmetric

(iii) Skew Symmetric

Q.10  $A = \begin{bmatrix} 0 & -1 & -2 \\ 1 & 0 & -1 \\ 2 & 1 & 0 \end{bmatrix}$  Skew Symmetric matrix

Q.10  $a = 1, \quad b = 0, \quad c = \frac{2}{5}, \quad d = \frac{3}{5}$

Q.11(i) 1760, 2090,

(ii) Profit of suresh book shop on P, C, M is ₹ 665, ₹675 ₹850 respectively. That of Ganesh ₹700, ₹750, ₹1020 respectively.

**Exercise : 4.5**

Q.2  $\begin{bmatrix} 5 & 4 \\ -3 & 23 \end{bmatrix}$

Q.3  $C = \begin{bmatrix} -10 & -1 & 1 \\ 7 & -9 & 3 \\ -4 & 6 & 2 \end{bmatrix}$

Q.4  $X = \begin{bmatrix} -1 & \frac{2}{5} \\ \frac{6}{5} & \frac{19}{5} \\ \frac{19}{5} & \frac{26}{5} \end{bmatrix}$

Q.5  $X = \begin{bmatrix} \frac{3}{8} & -\frac{1}{4} \\ -\frac{3}{8} & \frac{1}{2} \end{bmatrix}, \quad Y = \begin{bmatrix} \frac{1}{8} & \frac{1}{4} \\ -\frac{1}{8} & \frac{1}{2} \end{bmatrix}$

Q.6  $A = \begin{bmatrix} 3 & -\frac{14}{3} & -\frac{8}{3} \\ -2 & 1 & 3 \end{bmatrix}, \quad B = \begin{bmatrix} 0 & -\frac{10}{3} & -\frac{16}{3} \\ 0 & 0 & 5 \end{bmatrix}$

Q.7  $\begin{bmatrix} 1 & 0 \\ 0 & 1 \end{bmatrix}$

Q.8  $A - B$  is singular

Q.9  $x = -\frac{1}{4}, \quad y = \frac{9}{2}$

**Exercise : 4.6**

Q.1 (i)  $\begin{bmatrix} 6 & -12 & 9 \\ 4 & -8 & 6 \\ 2 & -4 & 3 \end{bmatrix}$  (ii) [8]

Q.3  $AB \neq BA$

Q.8  $\begin{bmatrix} -5 & -15 \\ 33 & 35 \end{bmatrix}$

Q.10  $\begin{bmatrix} 9 & 6 & 4 \\ 15 & 32 & -2 \\ 35 & -7 & 29 \end{bmatrix}$

Q.11  $\alpha = 1$

Q.13  $k = -7$

Q.17  $a = 2, b = -1$

Q.18  $X = \begin{bmatrix} 5 \\ 3 \\ 7 \\ 3 \end{bmatrix}$

Q.19  $K = 1$

Q.20  $x = -5/3$

Q.21  $x = 19, y = 12$

Q.22  $x = -3, \quad y = 1, \quad z = -1$

Q.24 Jay ₹104 and Ram ₹150.

**Exercise : 4.7**

Q.1 (i)  $\begin{bmatrix} 1 & -4 \\ 3 & 5 \end{bmatrix}$  (ii)  $\begin{bmatrix} 2 & -4 \\ 6 & 0 \\ 1 & 5 \end{bmatrix}$

Q.2  $A = \begin{bmatrix} 0 & -2 & -4 \\ 2 & 0 & -2 \\ 4 & 2 & 0 \end{bmatrix}$   $A^T = \begin{bmatrix} 0 & 2 & 4 \\ -2 & 0 & 2 \\ -4 & -2 & 0 \end{bmatrix}$

both are skew symmetric.

Q.7  $C^T = \begin{bmatrix} -16 & 14 \\ -6 & -10 \end{bmatrix}$

Q.8 (i)  $\begin{bmatrix} 7 & 8 \\ -5 & 8 \\ 12 & -18 \end{bmatrix}$  (ii)  $\begin{bmatrix} 35 & -10 \\ 25 & 15 \\ -15 & 10 \end{bmatrix}$

Q.12 (i)  $\begin{bmatrix} 4 & \frac{1}{2} \\ \frac{1}{2} & -5 \end{bmatrix} + \begin{bmatrix} 0 & -\frac{5}{2} \\ \frac{5}{2} & 0 \end{bmatrix}$

(ii)  $\frac{1}{2} \begin{bmatrix} 6 & 1 & -5 \\ 1 & -4 & -4 \\ -5 & -4 & 4 \end{bmatrix} + \frac{1}{2} \begin{bmatrix} 0 & 5 & 3 \\ -5 & 0 & 6 \\ -3 & -6 & 0 \end{bmatrix}$

**MISCELLANEOUS EXERCISE - 4 (B)**

(I)

1	2	3	4	5	6	7	8	9	10
B	C	A	D	A	C	B	A	A	C

(II) Q.1 (i) diag  $[-1 \ 1 \ 3]$  (ii) diag  $[23 \ -32 \ -18]$

Q.2 (i)  $\begin{bmatrix} \cos \alpha & \sin \alpha & 0 \\ -\sin \alpha & \cos \alpha & 0 \\ 0 & 0 & 1 \end{bmatrix}$

(ii)  $\begin{bmatrix} 2 \cos \alpha & 0 & 0 \\ 0 & 2 \cos \alpha & 0 \\ 0 & 0 & 2 \end{bmatrix}$

Q.3 (i)  $A = \frac{1}{7} \begin{bmatrix} 3 & -4 \\ 1 & 3 \end{bmatrix}$   $B = \begin{bmatrix} -\frac{1}{7} & -\frac{1}{7} \\ \frac{2}{7} & -\frac{1}{7} \end{bmatrix}$

(ii)  $A = \frac{1}{16} \begin{bmatrix} -5 & 10 & 6 \\ 4 & 0 & 25 \end{bmatrix}$   $B = \frac{1}{16} \begin{bmatrix} 1 & -2 & 2 \\ -4 & 0 & -5 \end{bmatrix}$

Q.5  $\alpha = 60^\circ$  or  $\frac{\pi}{3}$

Q.16  $x = 2, y = 2$

Q.18  $\begin{bmatrix} 2 & -1 \\ 3 & -2 \end{bmatrix}$

Q.19 (i)  $x = 7, y = -44$  (ii)  $x = 5, y = -1$

Q.20 (i)  $x = -9, y = -3, z = 0.$

(ii)  $x = 31, y = 53, z = 19.$

Q.21  $AB^T = \begin{bmatrix} 8 & -7 \\ -12 & 22 \end{bmatrix}$   $A^T B = \begin{bmatrix} 2 & 0 & -4 \\ 7 & -2 & 6 \\ 15 & -6 & 30 \end{bmatrix}$

Q.25 (i)

	Shantaram	Kantaram
Rice	₹ 33000	₹ 39000
Wheat	₹ 28000	₹ 31500
Groundnut	₹ 24000	₹ 24000

(ii)

	Shantaram	Kantaram
Rice	₹ 3000	₹ 3000
Wheat	₹ 2000	₹ 1500
Groundnut	₹ 0	₹ 8000

## 5. STRAIGHT LINE

### Exercise : 5.1

- $2x - 4y + 5 = 0$
- $9x - y + 6 = 0$
- $3x^2 + 3y^2 + 4x + 24y + 32 = 0$
- $x^2 + y^2 - 11x - 11y + 53 = 0$
- $3x + 4y - 41 = 0$
- $3x^2 + 4y^2 - 4x - 11y + 33 = 0$
- (a)  $(-1, 0)$                       (b)  $(0, 2)$
- (a)  $(6, 7)$                           (b)  $(4, 6)$
- $(-3, 11)$
- (a)  $3X - Y + 6 = 0$   
(b)  $X^2 + Y^2 + X + 4Y - 5 = 0$   
(c)  $XY = 0$   
(d)  $Y^2 - 4X = 0$

### Exercise : 5.2

- a) 2    b)  $\frac{4}{7}$     c) not defined.    d) 0.
- $\frac{-3}{2}$     3.  $\frac{1}{\sqrt{3}}$     4. 1    5. -1
- 1    8.  $k = 1$     9.  $45^\circ$

### Exercise : 5.3

- a)  $y = 5$     b)  $y = -5$     c)  $y = -1$  or  $y = 7$
- a)  $y = 3$     b)  $x = 4$
- a)  $x = 2$     b)  $y = -3$
- a)  $4x - y - 8 = 0$     b)  $x = 2$
- a)  $y = \sqrt{3}x$     b)  $y = -3x$   
c)  $x - 2y - 7 = 0$     d)  $2x - 3y + 9 = 0$   
e)  $\sqrt{3}x + y - 4\sqrt{3} - 3 = 0$   
f)  $3x - y = 0$

- $m = 1, c = -1$
- $x + y - 7 = 0$
- a)  $2x + y - 4 = 0$     b)  $2x - 5y + 14 = 0$   
c)  $2x + 4y - 13 = 0$
- a) 3, 2    b)  $\frac{2}{3}, \frac{3}{2}$     c) -6, 4
- $x - y + 2 = 0, 3x - y = 0$
- $x + y = 7, 4x - 3y = 0$
- A :  $5x + y - 15 = 0$  ,    B :  $3x + 4y - 14 = 0$ ,  
C :  $2x - 3y - 1 = 0$
- $9x + y + 7 = 0, 8x + 22y - 31 = 0, 2x - 4y + 9 = 0$
- $\left(\frac{5}{7}, \frac{4}{7}\right)$
- $3x - 4y = 25$

### Exercise : 5.4

- a) Slope  $-\frac{2}{3}$ , X-intercept 3, Y-Intercept 2  
b) Slope 3, X-intercept 3, Y-Intercept -9  
c) Slope  $-\frac{1}{2}$ , intercepts 0
- a)  $2x - y - 4 = 0$     b)  $0x + 1y - 4 = 0$   
c)  $2x + y - 4 = 0$     d)  $2x - 3y - 6 = 0$
- $(1, -3)$     5.  $\pm 24$     6.  $(1, 2)$
- $(1, -1)$     8.  $\left(\frac{5}{3}, \frac{2}{3}\right)$     9.  $(5, 5)$
- $x + 3y = 3$     11. 2    12. 4
- $\frac{2}{5}$     14.  $\frac{25}{\sqrt{117}}$     15.  $(3, 1)$  and  $(-7, 11)$
- $5y - 8 = 0$     17.  $8x + 13y - 24 = 0$
- $x - 3y + 5 = 0$
- $2x + y + 13 = 0, x - 9y + 73 = 0,$   
 $11x - 4y - 52 = 0, \left(\frac{-1}{19}, \frac{-10}{19}\right)$
- $(2, 2)$

**MISCELLANEOUS EXERCISE - 5**

(I)

1	2	3	4	5	6	7	8	9	10
B	C	B	D	B	B	D	B	A	D

- a) 22      b)  $\frac{5}{3}$       c) 1
- $y = -2x - \frac{8}{3}$ , slope = -2
- 2
- No, point does not satisfy the equation.
- (d)
- a)  $y + 3 = 0$       b)  $x = -2$   
c)  $y = 5$       d)  $x = 3$
- a)  $y = 3$       b)  $y = 4$
- a)  $5x - y + 7 = 0$     b)  $x = 7$     c)  $3x - 2y = 0$
- $x = 2$
- 6
- $\frac{12}{5}$
- $x + y = 8$  or  $5x - 3y = 0$
- a) BC :  $3x + y = 9$ , CA :  $x = 1$ . AB :  $x + y = 5$   
b) Median AD :  $x - y + 3 = 0$ ,  
Median BE :  $2x + y = 7$ ,  
Median CF :  $5x + y - 11 = 0$   
c)  $x - 3y + 12 = 0$ ,  $y = 5$ ,  $x - y + 2 = 0$   
d)  $x - 3y + 11 = 0$ ,  $y = 3$ ,  $x - y + 5 = 0$
- $3y - 7 = 0$
- $17x + 27y - 17 = 0$
- $x + 3y = 7$
- $-\frac{4}{3}$
- 5
- $\frac{22}{9}$

- $3x + y = 9$  and  $x - 3y + 7 = 0$
- 20
- $x - 2y + 14 = 0$ ,  $x + 2y = 32$
- $y = 3$ , (1, 3)
- $3x - 4y + 8 = 0$
- $3x + 9y = 13$
- $\left(\frac{68}{25}, \frac{-49}{25}\right)$
- (-2, 0) and (8, 0)
- $2x - 9y + 85 = 0$
- $3\sqrt{2}$

**6. CIRCLE**

**Exercise : 6.1**

- (i)  $x^2 + y^2 = 16$   
(ii)  $x^2 + y^2 + 6x - 4y - 23 = 0$   
(iii)  $x^2 + y^2 - 4x + 6y - 12 = 0$   
(iv)  $x^2 + y^2 + 6x + 6y + 9 = 0$
- (i) (0, 0); 5      (ii) (5, 3);  $2\sqrt{5}$   
(iii)  $\left(\frac{1}{2}, -\frac{1}{3}\right); \frac{1}{6}$
- (i)  $x^2 + y^2 - 2ax - 2by + b^2 = 0$   
(ii)  $x^2 + y^2 + 4x - 6y + 4 = 0$   
(iii)  $x^2 + y^2 \pm 8x = 0$   
(iv)  $x^2 + y^2 - 6x - 2y + 6 = 0$
- $x^2 + y^2 - 16x + 20y + 83 = 0$
- $x^2 + y^2 - 2x - 4y = 0$
- $x^2 + y^2 + 8x + 8y + 16 = 0$
- $x^2 + y^2 - 4x + 5y = 0$
- $x^2 + y^2 + 6x - 6y + 47 = 0$

**Exercise : 6.2**

(1) (i) (1, -2); 3 (ii) (3, 4); 7 (iii) (3, 1), 4

(3)  $x^2 + y^2 - 4x - 6y - 12 = 0$

**Exercise : 6.3**

(1) (i)  $x = 3 \cos \theta, y = 3 \sin \theta$

(ii)  $x = -1 + 3 \cos \theta, y = 2 + 3 \sin \theta$

(iii)  $x = 3 + 5 \cos \theta, y = -4 + 5 \sin \theta,$

(2)  $x = \frac{2}{3} + \frac{5}{3} \cos \theta, y = -1 + \frac{5}{3} \sin \theta$

(3)  $3x - 2y = 0$

(5)  $4x - y - 18 = 0$

**MISCELLANEOUS EXERCISE - 6**

(I)

1	2	3	4	5	6	7	8	9	10
C	C	A	C	A	C	D	C	B	A

(II) (1)  $\left(\frac{1}{2}, -1\right), \frac{\sqrt{17}}{2}$  (2) (3,2), 4

(3)  $x^2 + y^2 + 4x - 2y = 0$

(4)  $x^2 + y^2 - 4x - 6y = 0$

(6)  $x^2 + y^2 - 6y - 76 = 0$

(8)  $x + \sqrt{3} y + 16 = 0$

(9)  $x^2 + y^2 = 50$

(10)  $x^2 + y^2 - 4x + 6y - 3 = 0$

(11) (i) x-intercept = 12, r - intercept = 9

(ii) x-intercept = 9, r - intercept = 15

(12) (i)  $\left(\frac{1}{5}, \frac{-13}{5}\right), 3x - 4y - 11 = 0$

(ii) (1, 2),  $x + 3y - 7 = 0$

(13) (i) (2, -4),  $y + 4 = 0$

(ii)  $\left(\frac{8}{5}, \frac{6}{5}\right), 3x - 4y = 0$

(14) 7 (15)  $k = -8$

(16)  $3x + 2y - 26 = 0$  (17)  $x - 2y = 5$

(18)  $x + \sqrt{3} y = 10$  (19) (-3, 0)

(20) -61 (21)  $2x + y \pm 4\sqrt{5} = 0$

(22)  $3x + 2y \pm 2\sqrt{13} = 0$

(23)  $x - 5y \pm 6\sqrt{26} = 0$

(24)  $3x - y - 27 = 0$  and  $3x - y - 13 = 0$

(25)  $x^2 + y^2 = 18$

(26) (i)  $xy = 0$  (ii)  $5y^2 + 2xy = 5a^2$

(iii)  $y^2 - a^2 = c(x^2 - a^2)$

**7. CONIC SECTIONS**

**Exercise : 7.1**

1) i.  $\left(\frac{6}{5}, 0\right), 5x + 6 = 0, \frac{24}{5}, \left(\frac{6}{5}, \pm \frac{12}{5}\right)$

ii. (-5, 0),  $x - 5 = 0, 20, (-5, \pm 10)$

iii.  $\left(0, \frac{2}{3}\right), 3y + 2 = 0, \frac{8}{3}, \left(\pm \frac{4}{3}, \frac{2}{3}\right)$

iv. (0, -2),  $y - 2 = 0, 8, (\pm 4, -2)$

v.  $\left(-\frac{4}{3}, 0\right), 3x - 4 = 0, \frac{16}{3}, \left(-\frac{4}{3}, \pm \frac{8}{3}\right)$

2)  $x^2 = -20y$

3)  $3y^2 = 16x$

4)  $y^2 = -28x$

5) i)  $y^2 = 36x$  ii)  $y^2 = \frac{9}{2}x$

6) i)  $-\frac{3}{2}$  ii)  $-\frac{9}{2}$

7) 8

8) i)  $\left(\frac{1}{3}, 2\right), \frac{10}{3}$  ii)  $\left(\frac{7}{2}, -\frac{7}{2}\right), \frac{35}{8}$

9) (16, 8), (16, -8)

10) 18 units

11) 18 sq. units

12) (5, 0)

13)  $(1, 2), \left(1, \frac{9}{4}\right)$ ,

$$4y - 7 = 0,$$

$$x = 1$$

14) i)  $x - y + 3 = 0, 3x - 2y + 4 = 0$

ii)  $3x - y + 3 = 0, 3x - 2y + 12 = 0$

15)  $k = 24$

17)  $x + 2y + 4 = 0$

18)  $y = -3x$

19)  $\frac{29}{4} = 7.25\text{cm}$

### Exercise : 7.2

(1) (a) 10, 6,  $(\pm 50)$ ,  $x = \pm \frac{a}{e}; \frac{18}{5}, 8, \frac{25}{2}$ .

(b) 4,  $2\sqrt{3}$ ,  $(\pm 10)$ ,  $x = \pm 4, 3, 2, 8$ .

(c)  $2\sqrt{3}, 2, (\pm \sqrt{2}, 0)$ ,  $x = \pm \frac{3}{\sqrt{2}}, \frac{2}{\sqrt{3}}$ ,  
 $2\sqrt{2}, 3\sqrt{2}$ .

(d)  $\frac{2}{\sqrt{3}}, 1, \left(\pm \frac{1}{2\sqrt{3}}, 0\right)$   $x = \pm \frac{2}{\sqrt{3}}, \frac{\sqrt{3}}{2}$ ,  
 $\frac{1}{\sqrt{3}}, \frac{4}{\sqrt{3}}$

(2) (i)  $\frac{x^2}{64} + \frac{y^2}{55} = 1$  (ii)  $\frac{x^2}{25} + \frac{y^2}{9} = 1$

(iii)  $\frac{x^2}{9} + \frac{y^2}{8} = 1$  (iv)  $\frac{x^2}{72} + \frac{y^2}{64} = 1$

(v)  $\frac{x^2}{25} + \frac{y^2}{16} = 1$  (vi)  $\frac{x^2}{16} + \frac{y^2}{12} = 1$

(vii)  $3x^2 + 5y^2 = 32$  (viii)  $\frac{x^2}{15} + \frac{y^2}{6} = 1$

(ix)  $\frac{x^2}{9} + \frac{y^2}{5} = 1$

(4)  $e = \frac{2\sqrt{2}}{3}$

(5)  $e = \frac{1}{\sqrt{3}}$

(7) 4 sq. unit (8)  $\left(\frac{16}{5}, \frac{-9}{5}\right)$  (9) (1, 2)

(10) The line is a tangent and point of contact

$$\left(\frac{1}{3\sqrt{2}}, \frac{4\sqrt{2}}{3}\right).$$

(11)  $k = \pm 12\sqrt{2}$

(12) (i)  $y + 2 = 0, 8x - y - 18 = 0$

(ii)  $y + 2 = 0, 12x + y = 34$

(iii)  $5x - y = 9, x + y = 3$

(iv)  $6y = \pm (4x + 15)$

(v)  $x + y = \pm \sqrt{29}$

(vi)  $2x - y = \pm 3$ ,

(vii)  $3x - 4y = \pm 2\sqrt{65}$

(13)  $x^2 + y^2 = 8$  (14)  $x^2 - xy - 5 = 0$

(16)  $x^2 - y^2 = a^2 - b^2$  (19)  $x + y = \pm 5$

(20)  $\frac{x}{a} + \frac{y}{b} = \sqrt{2}$  (23) 3 sq. units

### Exercise : 7.4

(1) (i) 10, 8,  $\frac{\sqrt{41}}{5}, (\pm \sqrt{41}, 0)$ ,  $x = \pm \frac{25}{41}, \frac{32}{5}$

(ii) 8, 10,  $\frac{\sqrt{41}}{4}, y = \pm \frac{16}{\sqrt{41}}, \frac{32}{5}$

(iii)  $6, 8, \frac{5}{3}, (\pm 5, 0), x = \pm \frac{9}{5}, \frac{32}{3}$

(iv)  $4, 2\sqrt{21}, \frac{5}{2}, (\pm 5, 0), x = \pm \frac{4}{5}, 21$ .

(v)  $\frac{4}{\sqrt{3}}, 4, \sqrt{3}, \left(\pm \frac{4}{\sqrt{3}}, 0\right), x = \pm \frac{2}{3}, 4\sqrt{3}$

(vi)  $8, 8, \sqrt{2}, (\pm 4\sqrt{2}, 0), x = \pm 2\sqrt{2}, 32$

(vii)  $10, 6, \frac{\sqrt{34}}{5}, (0, \pm \frac{\sqrt{34}}{5}), y = \pm \frac{25}{\sqrt{34}}, \frac{18}{5}$

(viii)  $10, 24, \frac{13}{5}, (0, \pm 13), y = \pm \frac{25}{13}, \frac{288}{5}$ .

(ix)  $20, 10, \frac{\sqrt{3}}{2}, (\pm 5\sqrt{3}, 0), x = \pm \frac{20}{\sqrt{3}}, 10$

(x)  $4, 4\sqrt{3}, 2, (\pm 4, 0), x = \pm 1, 12$ .

(2)  $\frac{x^2}{24} - \frac{y^2}{25} = 1$       (3)  $e = \frac{2}{\sqrt{3}}$

(5) (i)  $\frac{x^2}{4} - \frac{y^2}{21} = 1$       (ii)  $\frac{x^2}{16} - \frac{y^2}{9} = 1$

(iii)  $\frac{x^2}{4} - \frac{y^2}{5} = 1$       (iv)  $\frac{8x^2}{9} - \frac{y^2}{36} = 1$

(v)  $\frac{x^2}{9} - \frac{y^2}{27} = 1$       (vi)  $\frac{x^2}{49} - \frac{y^2}{9} = 1$

(vii)  $\frac{9x^2}{16} - \frac{9y^2}{20} = 1$       (ix)  $\frac{x^2}{16} - \frac{y^2}{9} = 1$

(6) (i)  $3x - \sqrt{2}y = 2; \sqrt{2}x + 3y = 3\sqrt{2} + 6$

(ii)  $x - y = 1; x + y = 7$

(iii)  $5x - 6\sqrt{3}y = 30; 6\sqrt{3}x + 5y = 169\sqrt{3}$

(iv)  $3\sqrt{2}x - 4y = 12; 4x + 3\sqrt{2}y = 25\sqrt{2}$

(v)  $5x - 4y = 16; 16x + 20y = 125$ .

(7)  $(-6, -2)$       (8)  $2\sqrt{10}$       (9)  $x + y = \pm 4$

(10)  $3x + 2y = \pm 4$

**MISCELLANEOUS EXERCISE - 7**

(I)

1	2	3	4	5	6	7	8	9	10
A	C	A	C	A	B	C	C	B	B

11	12	13	14	15	16	17	18	19	20
C	C	B	B	B	C	B	A	C	A

(II) 1) i)  $\left(\frac{17}{8}, 0\right), 8x + 17 = 0, \frac{17}{2}, \left(\frac{17}{8}, \frac{17}{4}\right)$

i)  $\left(0, \frac{6}{5}\right) 5y + 6 = 0, \frac{24}{5}, \left(\frac{12}{5}, \frac{6}{5}\right)$

2) i)  $(12, 12)$  ii)  $(27, -18)$  3)  $(8, 8)$  and  $(8, -8)$

4)  $3x + 4y + 12 = 0$

5)  $2x - y + 2 = 0$

6)  $9x - 4y + 4 = 0, x - 4y + 36 = 0$

8)  $x + y + 2 = 0, (2, 4), (2, -4)$

13) a) i)  $10, 6$  ii)  $(\pm 4, 0)$  iii)  $x = \frac{23}{4}$  iv)  $\frac{18}{5}$  v)  $8$

vi)  $\frac{25}{2}$

b) i)  $10, 8$  ii)  $(0, \pm 3)$  iii)  $y = \pm \frac{25}{3}$  iv)  $\frac{32}{5}$

v)  $6$  vi)  $\frac{50}{3}$

c) i)  $24, 10$  ii)  $(\pm 13, 0)$  iii)  $x = \pm \frac{144}{13}$  iv)  $\frac{25}{6}$

v)  $26$  vi)  $\frac{288}{13}$

d) i)  $8, 8$  ii)  $(\pm 4\sqrt{2}, 0)$  iii)  $x = \pm 2\sqrt{2}$  iv)  $8$

v)  $8\sqrt{2}$  vi)  $\sqrt{2}$

14) i)  $\frac{x^2}{64} + \frac{y^2}{55} = 1$  ii)  $\frac{x^2}{25} + \frac{y^2}{9} = 1$

iii)  $3x^2 + 5y^2 = 32$

15)  $e = \pm \frac{1}{\sqrt{3}}$       17)  $y = \pm 4$  or  $y = 8x + 2\sqrt{11}$

18)  $2x + 3y = 25$       19) (1,2)

20)  $x^2 - xy - 5 = 0$

22) i)  $\frac{x^2}{36} - \frac{4y^2}{25} = 1$       ii)  $\frac{x^2}{16} - \frac{y^2}{20} = 1$

iii)  $\frac{x^2}{4} - \frac{4y^2}{9} = 1$

23) i)  $17x - 2y + 17 = 0$       ii)  $10x - 3\sqrt{3}y = 15$

iii)  $32x - 25y = 400\sqrt{3}$

24) (3,2)      25)  $y = 2x \pm 4$

26)  $k(x^2 - a^2) = 2xy$

5) S.D. = 3.76

6)  $(C.V.)_P = 27.27$ ;  $(C.V.)_Q = 33.33$ ;

i) Worker P is more consistent.

ii) Worker Q seems to be faster in completing the job.

7)  $(C.V.)_1 = 1.07$        $(C.V.)_2 = 2.5$

i) First department has larger bill

ii) Second department has larger variability in wages.

8)  $(C.V.)_A = 18.6$ ;  $(C.V.)_B = 18.7$

Series B is more variable

9)  $(C.V.)_A = 80$ ;  $(C.V.)_B = 74.5$

Team B is more consistent.

10)  $(C.V.)_M = 10$ ;  $(C.V.)_S = 12$

The subject Statistic shows higher variability in marks.

## 8. MEASURES OF DISPERSION

### Exercise : 8.1

1) 38    2) 717    3) 11    4) 5    5) 10

### Exercise : 8.2

1)  $\sigma^2 = 8$ ;  $\sigma = 2.82$

2)  $\sigma^2 = 380$ ;  $\sigma = 19.49$

3)  $\sigma^2 = 32.39$ ;  $\sigma = 5.69$

4)  $\sigma^2 = 4.026$ ;  $\sigma = 2.006$

5)  $\sigma^2 = 3.0275$ ;  $\sigma = 1.74$

6)  $x = 58.2$ ;  $\sigma^2 = 653.76$ ;  $\sigma = 25.56$

7)  $\sigma^2x = 41.25$ ;  $\sigma x = 6.42$

8) 5 and 7

### Exercise : 8.3

1)  $\sigma_c = 5.15$

2)  $\sigma_c = 3.14$

3) C.V. = 6.32

4) C.V. = 20

## MISCELLANEOUS EXERCISE - 8

(I)

1	2	3	4	5	6	7	8	9	10
C	A	B	D	A	C	B	B	C	B

(II)

1) Range = 48

2) Range = 89

3) Range = Rs. 30

4) Range = 60

5)  $\sigma = 2.72$

6) S. D. = 14.14

7) S. D. = 1.48

8) S. D. = 13.42

9) S. D. = 16.85

10) A. M. = 72; S. D. = 13.92

11) Mean = 19.15; S. D. = 4.66

12) Mean = 41; S. D. = 7.1

13) Number of boys = 75  
combined S. D. = 10.07

- 14) combined S. D. = 2.65
- 15) C.V. = 26.65
- 16)  $(C.V.)_B = 6.67$   $(C.V.)_G = 6.38$   
Series of boys is more variable
- 17)  $(C.V.)_I = 22.22$   $(C.V.)_{II} = 20.83$   
Brand-I is more variable
- 18) C.V. = 29.76
- 19) C.V. = 31.35
- 20)  $(C.V.)_x = 9.21$ ;  $(C.V.)_y = 5.91$   
The variation is greater in the area of the field.
- 21)  $(C.V.)_U = 37.67$ ;  $(C.V.)_V = 55.5$   
i) Company U gives higher average life  
ii) Company U shows greater consistency in performance.
- 22)  $(C.V.)_1 = 15.50$   $(C.V.)_2 = 19.96$   
Height shows more variability
- (4, 1), (4, 2), (4, 3), (4, 4), (4, 5), (4, 6),  
(5, 1), (5, 2), (5, 3), (5, 4), (5, 5), (5, 6),  
(6, 1), (6, 2), (6, 3), (6, 4), (6, 5), (6, 6)}
- a) A : {(1, 2), (2, 1), (1, 3), (2, 2), (3, 1), (1, 5),  
(2, 4), (3, 3), (4, 2), (5, 1), (2, 6), (3, 5),  
(4, 4), (5, 3), (6, 2), (3, 6), (4, 5), (5, 4),  
(6, 3), (6, 6)}
- b) B : {(1, 6), (2, 5), (3, 4), (4, 3), (5, 2), (6, 1)}
- c) C : {(1, 1), (1, 2), (1, 3), (1, 4), (1, 5), (1, 6),  
(3, 1), (3, 2), (3, 3), (3, 4), (3, 5), (3, 6),  
(5, 1), (5, 2), (5, 3), (5, 4), (5, 5), (5, 6)}
- d) D : {(2, 1), (2, 2), (2, 3), (2, 4), (2, 5), (2, 6),  
(4, 1), (4, 2), (4, 3), (4, 4), (4, 5), (4, 6),  
(6, 1), (6, 2), (6, 3), (6, 4), (6, 5), (6, 6)}
- c) A and B are mutually exclusive and exhaustive.
- f) C and Dare mutually exclusive and exhaustive.

## 9. PROBABILITY

### Exercise : 9.1

- 1)  $S = \{RR, GR, BR, PR, RG, GG, BG, PG, RB, GB, BB, PB, RP, GP, BP, PP\}$   
a)  $A = \{RR, GR, RB, RP, GR, BR, PR\}$   
b)  $B = \{RG, RB, RP, GR, GB, GP, BR, BG, BP, PR, PG, PB\}$
- 2)  $S = \{(H, 1), (H, 2), (H, 3), (H, 4), (H, 5), (H, 6), (T, 1), (T, 2), (T, 3), (T, 4), (T, 5), (T, 6)\}$   
a)  $A = \{(T, 1), (T, 3), (T, 5)\}$   
b)  $B = \{(H, 2), (H, 3), (H, 5), (T, 2), (T, 3), (T, 5)\}$   
c)  $C = \{(H, 1), (H, 4)\}$
- 3) i) 56 ii) 120 iii) 720 iv) 1140
- 4)  $S = \{(1, 1), (1, 2), (1, 3), (1, 4), (1, 5), (1, 6), (2, 1), (2, 2), (2, 3), (2, 4), (2, 5), (2, 6), (3, 1), (3, 2), (3, 3), (3, 4), (3, 5), (3, 6)\}$
- 5) a)  $S = \{(5, 5), (5, 6), (5, 7), (5, 8), (6, 5), (6, 6), (6, 7), (6, 8), (7, 5), (7, 6), (7, 7), (7, 8), (8, 5), (8, 6), (8, 7), (8, 8)\}$   
b)  $S = \{(5, 6), (5, 7), (5, 8), (6, 5), (6, 7), (6, 8), (7, 5), (7, 6), (7, 8), (8, 5), (8, 6), (8, 7)\}$
- 6) a)  $\frac{1}{9}$  b)  $\frac{5}{12}$  c)  $\frac{1}{6}$  d)  $\frac{1}{9}$
- 7) a)  $\frac{8}{221}$  b)  $\frac{13}{102}$  c)  $\frac{12}{51}$  d)  $\frac{25}{102}$  e)  $\frac{13}{34}$
- 8) a)  $\frac{6}{5525}$  b)  $\frac{997}{1700}$  c)  $\frac{22}{425}$  d)  $\frac{16}{5525}$
- 9) a)  $\frac{1}{2}$  b)  $\frac{1}{2}$  c)  $\frac{7}{10}$
- 10) a)  $\frac{4}{25}$  b)  $\frac{8}{75}$  c)  $\frac{7}{25}$  d)  $\frac{1}{15}$
- 11) a)  $\frac{2}{7}$  12) i)  $\frac{25}{81}$  ii)  $\frac{5}{18}$
- 13) i)  $\frac{1}{6}$  ii)  $\frac{5}{6}$

14) i)  $\frac{1}{3}$     ii)  $\frac{2}{3}$     iii)  $\frac{1}{30}$     iv)  $\frac{4}{15}$

15)  $\frac{4!}{4^4} = \frac{3}{32}$     16)  $\frac{1}{105}$     17) i)  $\frac{7}{33}$     ii)  $\frac{14}{55}$

**Exercise : 9.2**

1)  $\frac{2}{3}$     2) i) 1    ii)  $\frac{8}{13}$

3) i) 0.85    ii) 0.74    iii) 0.15

4) a)  $\frac{22}{75}$     b)  $\frac{47}{75}$

5) 0.69    6)  $\frac{5}{18}$

7) a)  $\frac{1}{4}$     b)  $\frac{3}{8}$     c)  $\frac{3}{4}$

8)  $\frac{1}{2}$     9)  $m = 6$

10) i)  $\frac{7}{33}$     ii)  $\frac{21}{25}$     11)  $\frac{33}{50}$

**Exercise : 9.3**

1)  $\frac{2}{7}$     2)  $\frac{7}{22}$     3)  $\frac{1}{9}$

4) i)  $\frac{1}{17}$     ii)  $\frac{1}{16}$

5) a)  $\frac{17}{64}$     b)  $\frac{3}{64}$     c)  $\frac{61}{64}$     d)  $\frac{29}{64}$

6) i)  $\frac{9}{20}$     ii)  $\frac{11}{20}$     iii)  $\frac{9}{20}$     7)  $\frac{11}{25}$

8) a)  $\frac{14}{19}$  (0.733)    b)  $\frac{1}{7}$  (0.143)    c)  $\frac{5}{8}$  (0.625)

9) Independent

10) a)  $\frac{5}{32}$     b)  $\frac{23}{48}$     c)  $\frac{35}{96}$     d)  $\frac{61}{96}$

11) a)  $\frac{1}{4}$     b)  $\frac{1}{2}$

12) a)  $\frac{21}{40}$     b)  $\frac{19}{40}$     13)  $\frac{10}{21}$     14)  $\frac{1}{4}$

15)  $\frac{9}{169}$     16)  $\frac{901}{1680}$     18)  $\frac{1}{3}$

**Exercise : 9.4**

1) 0.60    2) i)  $\frac{27}{52}$     ii)  $\frac{25}{52}$

3)  $\frac{16}{99}$     4)  $\frac{4}{5}$     5)  $\frac{12}{37}$

6) T = Test positive, S = Sufferer, P(T) = Total probability = 0.10425

a)  $\frac{0.00475}{0.10425}$

b)  $P(S'/T') = \frac{P(T'/S)P(S)}{1 - P(T)} = \frac{0.8955}{0.8958}$

7)  $\frac{95}{127} = 0.748$     8)  $\frac{0.018}{0.166} = 0.108$

9) (a) Total Probability =  $\frac{2}{3}$     b)  $\frac{1}{2}$

10)  $\frac{20}{59}$

**Exercise : 9.5**

1) i)  $\frac{3}{5}$     ii)  $\frac{3}{5}$     2)  $\frac{16}{21}$     3) a)  $\frac{73}{105}$     b)  $\frac{32}{105}$

4) a)  $\frac{61}{96}$     b)  $\frac{35}{96}$     5) 65:23    6) 2:1

7) 81 : 44

**MISCELLANEOUS EXERCISE - 9**

(I)

1	2	3	4	5	6	7	8	9	10
D	A	A	D	B	C	D	D	C	B

II) 1) a)  $\frac{2}{15}$     b)  $\frac{9}{46}$     2)  $\frac{505}{1001}$     3)  $\frac{4}{7}$

4)  $\frac{1}{2}, 1, \frac{1}{3}$     5)  $\frac{6}{55}$     6)  $n(s) = \frac{12!}{(2!)^4}$

a)  $\frac{1}{66}$     b)  $\frac{1}{99}$     7)  $\frac{19}{90}$     8)  $\frac{3}{7}$

9)  $\frac{32}{49}$     10)  $\frac{16}{21}$     11) i)  $\frac{4}{5}$     ii)  $\frac{2}{3}$

12) a)  $\frac{2}{5}$     b)  $\frac{1}{4}$     c)  $\frac{3}{5}$     13)  $\frac{5}{28}$

14) a)  $\frac{23}{60}$     b)  $\frac{8}{23}$     15)  $\frac{1}{21}$

17)  $\frac{1}{11}$

18)  $P(\text{A win}) = \frac{6}{11}$ ,  $P(\text{B win}) = \frac{5}{11}$

16)  $P(\text{A}) = \frac{1}{3}$ ,  $P(\text{B}) = \frac{1}{2}$ ,  $P(\text{C}) = \frac{1}{2}$

19)  $\frac{2}{5}$

20)  $\frac{90}{92}$     21)  $\frac{2}{3}$     22)  $\frac{28}{69}$

23)  $\frac{1}{2}$



$$\begin{bmatrix} 1 & 0 & 4 \\ -2 & 1 & 3 \end{bmatrix} \times \begin{bmatrix} 3 & 1 & 0 \\ -2 & 0 & 5 \\ 4 & 3 & -1 \end{bmatrix} = \begin{bmatrix} 19 & 13 & -4 \\ 4 & 7 & 2 \end{bmatrix}$$

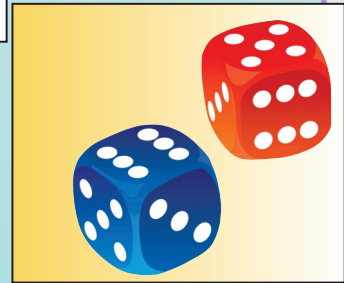

**Maharashtra State Bureau of Textbook Production  
and Curriculum Research,  
Pune - 411 004.**

**₹ 128.00**

इंग्रजी गणित आणि संख्याशास्त्र (कला व विज्ञान) भाग-१, इ. ११ वी