

Standard XI

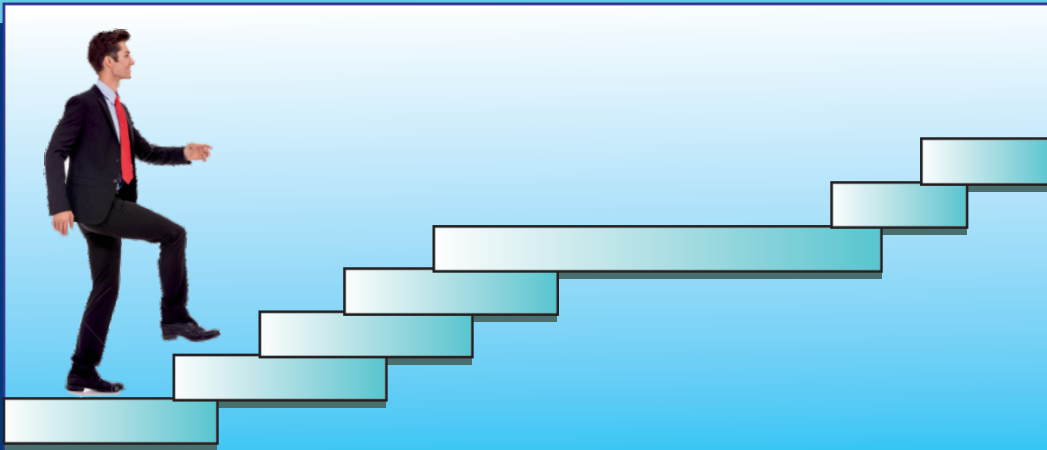

Mathematics & Statistics

Commerce Part 2



The Coordination Committee formed by GR No. Abhyas - 2116/(Pra.Kra.43/16) SD - 4
Dated 25.4.2016 has given approval to prescribe this textbook in its meeting held on
20.06.2019 and it has been decided to implement it from the educational year 2019-20.

Mathematics And Statistics

(Commerce)

Part-II

STANDARD ELEVEN



2019

**Maharashtra State Bureau of Textbook Production and Curriculum Research,
Pune - 411 004**



I2J8G7

Download DIKSHA App on your smartphone. If you scan the Q.R.Code on this page of your textbook, you will be able to access full text. If you scan the Q.R.Code, you will be able to access audio-visual study material relevant to each lesson, provided as teaching and learning aids.

First Edition : 2019

© Maharashtra State Bureau of Textbook Production
and Curriculum Research, Pune- 411 004

Maharashtra State Bureau of Textbook Production and Curriculum
Research reserves all rights relating to the book. No part of this book should
be reproduced without the written permission of the Director, Maharashtra
State Bureau of Textbook Production and curriculum Research, Pune.

Commerce Mathematics Paper II Committee Members

Dr. Sharad Gore	(Chairman)
Dr. Mangala Narlikar	(Member)
Smt. Prajakti Gokhale	(Member)
Shri. Prahallad Chippalagatti	(Member)
Shri. Prasad Kunte	(Member)
Shri. Sujit Shinde	(Member)
Shri. Sandeep Panchbhai	(Member)
Shri. Ramakant Sarode	(Member)
Smt. Pooja Jadhav	(Member)
Smt. Ujjwala Godbole	(Member-Secretary)

Commerce Mathematics Paper II Study Group Members

Dr. Ishwar Patil	Dr. Pradeep Mugale
Dr. Pradnyankumar Bhojankar	Shri. Milind Patil
Shri. Pradipkumar Bhavsar	Shri. Devanand Bagul
Shri. Uday Mahindrakar	Shri. Balkrishna Mapari
Shri. Prafullachandra Pawar	Shri. Sachin Batwal
Smt. Nileema Khaldkar	Shri. Swapnil Shinde
Smt. Swati Powar	Smt. Deepti Kharapas
Smt. Mahadevi Mane	Shri. Dilip Panchamia
Shri. Amit Totade	Shri. Pramod Deshpande
Shri. Vinayak Godbole	Smt. Gauri Prachand
Shri. Dhananjay Panhalkar	
Smt. Supriya Abhyankar	
Shri. Sharadchandra Walagade	

Chief Co-ordinator

Smt. Prachi Ravindra Sathe

Cover, Illustrations and Computer Drawings

Shri. Sandip Koli, Artist, Mumbai

Typesetter

Baladev Computers

Co-ordinator

Ujjwala Shrikant Godbole
I/C Special Officer for Mathematics

Production

Sachchitanand Aphale

Chief Production Officer

Sanjay Kamble

Production Officer

Prashant Harne

Asst. Production Officer

Paper

70 GSM Cream wove

Print Order No.

N/PB/2019-20/20,000

Printer

SHRI GANRAJ PRINTING AND BINDING
WORKS, KOLHAPUR

Publisher

Vivek Uttam Gosavi, Controller

Maharashtra State Textbook Bureau,
Prabhadevi Mumbai- 400 025



The Constitution of India

Preamble

WE, THE PEOPLE OF INDIA, having solemnly resolved to constitute India into a SOVEREIGN SOCIALIST SECULAR DEMOCRATIC REPUBLIC and to secure to all its citizens :

JUSTICE, social, economic and political ;

LIBERTY of thought, expression, belief, faith and worship ;

EQUALITY of status and of opportunity ;
and to promote among them all

FRATERNITY assuring the dignity of the individual and the unity and integrity of the Nation ;

IN OUR CONSTITUENT ASSEMBLY this twenty-sixth day of November, 1949, do HEREBY ADOPT, ENACT AND GIVE TO OURSELVES THIS CONSTITUTION.

NATIONAL ANTHEM

Jana-gana-mana-adhināyaka jaya hē
Bhārata-bhāgya-vidhātā,

Panjāba-Sindhu-Gujarāta-Marāthā
Drāvida-Utkala-Banga

Vindhya-Himāchala-Yamunā-Gangā
uchchala-jaladhi-taranga

Tava subha nāmē jāgē, tava subha āsisa māgē,
gāhē tava jaya-gāthā,

Jana-gana-mangala-dāyaka jaya hē
Bhārata-bhāgya-vidhātā,

Jaya hē, Jaya hē, Jaya hē,
Jaya jaya jaya, jaya hē.

PLEDGE

India is my country. All Indians
are my brothers and sisters.

I love my country, and I am proud
of its rich and varied heritage. I shall
always strive to be worthy of it.

I shall give my parents, teachers
and all elders respect, and treat
everyone with courtesy.

To my country and my people,
I pledge my devotion. In their
well-being and prosperity alone lies
my happiness.

PREFACE

Dear Students,

Welcome to the eleventh standard!

You have successfully completed your secondary education and have entered the higher secondary level. You will now need to learn certain mathematical concepts and acquire some statistical skills to add accuracy and precision to your work. Maharashtra State Bureau of Text Book Production and Curriculum Research has modified and restructured the curriculum in Mathematics and Statistics for the Commerce stream in accordance with changing needs of the society.

The curriculum of Mathematics and Statistics is divided in two parts. Part-1 covers topics in Algebra, Co-ordinate Geometry, Complex Numbers, Sets and Relations, functions and Calculus. Part-2 covers Combinatorics and Statistics. There is a special emphasis on applications. Activities are added at the end of every chapter for creative thinking. Some material will be made available on E-balbharati website (e-balbharati.in). It contains a list of specimen practical problems on each chapter. Students should complete the practical exercises under the guidance of their teachers. Journals are to be maintained by students and assessed by teachers.

You are encouraged to use modern technology in your studies. Explore the Internet for more recent information on topics in the curriculum. Get more examples and practice - problems from the Internet. You will enjoy learning if you follow three simple principles: a thorough study of the textbook, learning based on activities, and continuous practice of solving problems.

This textbook is prepared by mathematics subject committee and study group. This book has also been reviewed by senior teachers and eminent scholars. The Bureau would like to thank all of them for their contribution in the form of creative writing, constructive criticism, and valuable suggestions in making this book useful. Also the Bureau is grateful to members of the mathematics subject committee, study group and reviewers for sparing their valuable time in preparing this book. The Bureau hopes that the textbook will be received well by all users in the right spirit.

You are now ready to study. Best wishes for a happy learning experience.



(Dr. Sunil Magar)
Director

Maharashtra State Bureau of Textbook
Production and Curriculum Research, Pune.

Pune

Date : 20 June 2019,

Indian Solar Date : 30 Jyeshtha 1941

Competency statements

Sr. No	Area	Topic	Competency Statement
1	Partition Values	Partition Values	<p>The student will be able to</p> <ul style="list-style-type: none"> • calculate specified partition values for given ungrouped data • calculate specified partition values for grouped data (using formulae and graphs)
2	Measures of Dispersion	Measures of Dispersion	<ul style="list-style-type: none"> • calculate range, quartiles and quartile deviation for given data • calculate variance and standard deviation from given data • calculate measures of dispersion for grouped data
3	Skewness	Skewness	<ul style="list-style-type: none"> • decide if the given frequency distribution is symmetric • calculate Pearson's coefficient of skewness • calculate Bowley's coefficient of skewness
4	Bivariate Frquency Distribution	Bivariate Frequency Distribution	<ul style="list-style-type: none"> • construct a bivariate frequency distribution for given raw data • find marginal and conditional frequency distributions from given bivariate frequency distribution. • find χ^2 statistic.
5	Correlation	Correlation	<ul style="list-style-type: none"> • compute correlation coefficient for given bivariate data • compute correlation coefficient for a bivariate frequency table. • compute coefficient of determination.
6	Permutation and combination	Permutation and combination	<ul style="list-style-type: none"> • count the number of arrangements of given objects satisfying specified conditions • count the number of possible selections of objects satisfying specified conditions

7	Probability	Probability	<ul style="list-style-type: none"> • calculate probabilities of events in a random experiment • calculate probability of an event using description of an experiment • calculate probabilities of events obtained using algebra of events.
8	Linear Inequations	Linear Inequations	<ul style="list-style-type: none"> • identify sets of numbers satisfying given in - equations • solve a given set of in equations graphically
9	Commercial Mathematics	Percentage	<ul style="list-style-type: none"> • calculate percentages from given information • compare quantities in terms of percentages
		Profit and Loss	<ul style="list-style-type: none"> • calculate profit/loss from descriptions of a commercial activity/transaction • express profit/loss in terms of percentages
		Interest	<ul style="list-style-type: none"> • calculate simple interest • calculate compound interest
		GST	<ul style="list-style-type: none"> • calculate CGST, SGST and UTGST • calculate input tax and output tax • calculate input tax credit at different stages of trade
		Shares	<ul style="list-style-type: none"> • calculate dividend on shares • understand concepts of face value, market value, nominal value and par value of shares • calculate brokerage in a given transaction
		Partnership	<ul style="list-style-type: none"> • understand types of partnerships • understand levels of involvement of partners in a specified business
		Depreciation	<ul style="list-style-type: none"> • calculate depreciation using the initial value, period and duration of use of an asset • calculate present value from initial value for a given rate of depreciation and a specified duration after purchase of an asset



INDEX

Sr. No.	Chapter	Page No.
1	Partition Values	1
2	Measures of Dispersion	24
3	Skewness	37
4	Bivariate Frequency Distribution and CHI Square Statistic	45
5	Correlation	56
6	Permutations and Combinations	65
7	Probability	95
8	Linear Inequations	112
9	Commercial Mathematics	123
10	Answers	146

1. PARTITION VALUES



Let's Study

- Partition values - Quartiles, deciles, percentiles.
- Graphical location of partition values



Let's Recall

Median – If the numbers in a data are arranged in ascending order, the number at the middle position is called the median of the data. It divides the array of numbers in two equal parts that is the number of scores below and above the median is same. If the number of observations

are odd then, Median = $\left(\frac{n+1}{2}\right)^{th}$ observation.

where n = number of observation.

If the number of observations are even then,

Median = Mean of $\left(\frac{n}{2}\right)^{th}$ and $\left(\frac{n+2}{2}\right)^{th}$ observations

\therefore Median =

$$\frac{\left(\frac{n}{2}\right)^{th} \text{ observation} + \left(\frac{n+2}{2}\right)^{th} \text{ observation}}{2}$$

Activity: Complete the following table:

No.	Data	Median
1.	32,33,38,40,43	38
2.	32,33,38,40,43,48	<input type="text"/>
3.	61,62,65,66,68	<input type="text"/>

In previous standard, we have learnt Median for a grouped frequency distribution.

When the number of scores in the data is large, it is difficult to arrange them in ascending order. In such cases the data is divided into groups.

Ex.1 The following table shows frequency distribution of marks of 100 students of 10th class which they obtained in an examination. Find the median marks.

Marks in Exam	0-20	20-40	40-60	60-80	80-100
No. of students	4	20	30	40	6

Solution: $N = 100$, $\frac{N}{2} = 50$

C.I.	f	c.f.
0-20	4	4
20-40	20	24
40-60	30	54
60-80	40	94
80-100	6	100

Median class

$$= \left(\frac{N}{2}\right)^{th} \text{ observation}$$

$$= \text{class containing observation} \leq \frac{N}{2}$$

$$= 50^{th} \text{ observation}$$

\therefore Median class is 40 – 60

Here $L = 40$, $h = 20$, $f = 30$, $c.f. = 24$

$$\begin{aligned} \text{Median} &= L + \frac{h}{f} \left(\frac{N}{2} - c.f. \right) \\ &= 40 + \frac{20}{30} (50 - 24) \\ &= 40 + \frac{2}{3} (26) = 40 + 17.33 \\ &= 57.33 \end{aligned}$$

Ex.2 Find Median from the following frequency distribution table.

Age less than (yrs.)	10	20	30	40	50	60
No. of persons	3	10	22	40	54	71

Solution:

Age less than (yrs.)	Class	No. of persons (f)	$c.f.$
10	0-10	3	3
20	10-20	10-□ = □	10
30	□	□-□ = □	22
40	□	□-□ = □	40
50	□	□-□ = □	54
60	50-60	71-54 = □	71

Here $N = 71$, $\frac{N}{2} = 35.5$ and $h = \square$

Median class is 30-40

$L = \square$, $f = \square$, $c.f. = \square$

Median = \square

$$= 30 + \frac{10}{18} (35.5 - 22)$$

$$= 30 + \square$$

$$= \square$$

Median age of person = 37.5 years.

Introduction –

A certain school is interested in making four divisions of equal strength of 200 students, subject to their marks in their previous class.

The school is interested in a selection criterion for making divisions. Which selection procedure can be more appropriate? Can we select students at random? Will this be fair? Obviously not! Therefore, the school decides to arrange the students in descending order as per their marks and carries out scrutiny for four divisions. This procedure divides students in 4 equal parts of 25% each. In general it may be necessary to divide the data into a required number of equal parts depending upon the situation. This procedure of dividing the data into equal parts is called partitioning and the values that divide the data into the required number of equal parts are called partition values.



Let's Learn

1.1 Partition Values:-

Suppose we have the following data of marks of 15 students in Mathematics.

23,21,26,27,20,18,22,13,14,25,34,28,35,40,38.

Arrange the observations in ascending order of their magnitude.

13,14,18,**20**,21,22,23,**25**,26,27,28,**34**,35,38,40.

What can be said about positions of observations 20, 25, 34? There are 3 observations below 20, 3 observations between 20 and 25, 3 observations between 25 and 34 and 3 observations above 34. These values divide the data in 4 equal parts, so they are called partition values.

Definition : When the observations are arranged in ascending or descending order of their magnitude, and further, they are divided into 'n' equal parts ($n=2,3,\dots$), then observations which lie at partitioning positions are called partition values.

We have already studied the concept of one of the partition values namely median. Median

divides the data in two equal parts. Median is a special type of partition value because it divides the data in 2 equal parts. The median, quartiles, deciles and percentiles etc. are termed as partition values, since they divide the given data in equal parts.

We are going to study 3 types of partition values namely quartiles, deciles and percentiles.



Let's Learn

1.2 Quartiles:

Quartiles divide the observations in 4 equal parts when arranged in ascending order of magnitude. There are three quartiles, namely Q_1, Q_2 and Q_3 .

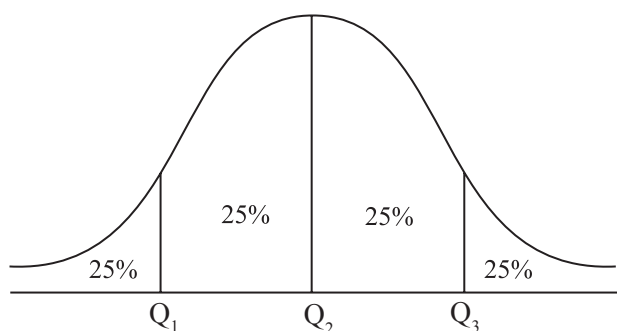

Fig. 1.1

Q_1 is the first or lower quartile. 25% observations are below Q_1 and 75% are above Q_1 .

Q_2 is the second quartile (median) which divides data into two equal parts 50% observations are above and 50% below it

Q_3 is the third or upper quartile. 75% of the observations are below Q_3 and 25% are above Q_3 .

The formula for quartiles for raw data is as follows:

$$i^{\text{th}} \text{ Quartile} = Q_i = \text{value of } \left[i \left(\frac{n+1}{4} \right) \right]^{\text{th}} \text{ observation,}$$

$i = 1, 2, 3$

where n is the total number of observations.

In particular, if the value of $i \left(\frac{n+1}{4} \right)$ is 6.25, the value of i^{th} quartile is calculated as follows:

$$i^{\text{th}} \text{ Quartile} = \text{value of } 6^{\text{th}} \text{ observation} + 0.25 (\text{value of } 7^{\text{th}} \text{ observation} - \text{value of } 6^{\text{th}} \text{ observation})$$

The formula of quartiles for grouped data is as follows:

$$Q_i = L + \frac{h}{f} \left(\frac{iN}{4} - c.f. \right), \quad i = 1, 2, 3$$

i^{th} Quartile class is the class in which $\left(\frac{iN}{4} \right)^{\text{th}}$ observation lies.

Where L = lower boundary of i^{th} quartile class

h = class width of i^{th} quartile class

f = frequency of i^{th} quartile class

$c.f.$ = less than cumulative frequency of the class just preceding i^{th} quartile class

N = total frequency.

SOLVED EXAMPLES

Ex.1: The marks of 19 students are given below:
41, 21, 38, 27, 31, 45, 23, 26, 29, 30, 28, 25, 35, 42, 47, 50, 29, 31, 35.

Calculate all the quartiles for the above data.

Solution: First arrange the data in ascending order as follows:

21, 23, 25, 26, 27, 28, 29, 29, 30, 31, 31, 35, 35, 38, 41, 42, 45, 47, 50.

Here, $n = 19$

$$Q_1 = \text{value of } \left(\frac{19+1}{4} \right)^{\text{th}} \text{ observation}$$

$$= \text{value of } 5^{\text{th}} \text{ observation}$$

$$Q_1 = 27$$

$$Q_2 = \text{value of } \left[2 \left(\frac{19+1}{4} \right) \right]^{th} \text{ observation}$$

$$= \text{value of } 10^{th} \text{ observation}$$

$$Q_2 = \square$$

$$Q_3 = \text{value of } \left[3 \left(\frac{19+1}{4} \right) \right]^{th} \text{ observation}$$

$$= \text{value of } 15^{th} \text{ observation}$$

$$Q_3 = 41$$

Ex.2: Calculate the quartiles for daily wages (₹) by 12 workers: 200, 280, 310, 180, 190, 170, 320, 330, 220, 210, 380, 400.

Solution: First arrange the data in ascending order as follows:

170, 180, 190, 200, 210, 220, 280, 310, 320, 330, 380, 400

Here, $n = 12$

$$Q_1 = \text{value of } \left(\frac{12+1}{4} \right)^{th} \text{ observation}$$

$$= \text{value of } 3.25^{th} \text{ observation}$$

$$= \text{value of } 3^{rd} \text{ observation} + 0.25 \text{ (value of } 4^{th} \text{ observation} - \text{Value of } 3^{rd} \text{ observation)}$$

$$= 190 + 0.25(200-190)$$

$$Q_1 = 192.5.$$

$$Q_2 = \text{value of } \left[2 \left(\frac{12+1}{4} \right) \right]^{th} \text{ observation}$$

$$= \text{value of } 6.5^{th} \text{ observation}$$

$$= \text{value of } 6^{th} \text{ observation} + 0.5 \text{ (value of } 7^{th} \text{ observation} - \text{value of } 6^{th} \text{ observation)}$$

$$= 220 + 0.5(280-220)$$

$$= 220 + 0.5(60)$$

$$Q_2 = 250$$

$$Q_3 = \text{value of } \left[3 \left(\frac{12+1}{4} \right) \right]^{th} \text{ observation}$$

$$= \text{value of } 9.75^{th} \text{ observation}$$

$$= \text{value of } 9^{th} \text{ observation} + 0.75 \text{ (value of } 10^{th} \text{ observation} - \text{value of } 9^{th} \text{ observation)}$$

$$= 320 + 0.75(330-320)$$

$$= 327.5$$

Ex.3: Calculate the quartiles for the following data:

Height (in inches)	4.8	4.9	5.0	5.1	5.2	5.3	5.4	5.5	5.6	5.7
No. of Students	5	7	13	16	25	14	9	6	3	2

Solution: Construct the less than cumulative frequency table as follows:

Height (in inches)	No. of students (f)	Less than cumulative frequency
4.8	5	5
4.9	7	12
5.0	13	25
5.1	16	41 ← Q_1
5.2	25	66 ← Q_2
5.3	14	80 ← Q_3
5.4	9	89
5.5	6	95
5.6	3	98
5.7	2	100
Total	100	-

Here, $n = 100$,

By comparing $\left[i \left(\frac{n+1}{4} \right) \right]^{th}$ with cumulative frequencies, one can easily locate the quartiles.

$$Q_1 = \text{value of } \left[1 \left(\frac{100+1}{4} \right) \right]^{th} \text{ observation}$$

$$= \text{value of } 25.25^{th} \text{ observation}$$

$$Q_1 = 25^{th} \text{ observation} + 0.25 \text{ (26}^{th} \text{ observation} - 25^{th} \text{ observation)}$$

$$= 5 + 0.25 (5.1 - 5)$$

$$= 5 + 0.025$$

$$Q_1 = 5.025$$

$$Q_2 = \text{value of } \left[2 \left(\frac{100+1}{4} \right) \right]^{th} \text{ observation}$$

$$= \text{value of } 50.5^{th} \text{ observation}$$

$$Q_2 = 5.2$$

$$Q_3 = \text{value of } \left[3 \left(\frac{100+1}{4} \right) \right]^{th} \text{ observation}$$

$$= \text{value of } 75.75^{th} \text{ observation}$$

$$Q_3 = 5.3$$

Ex.4: A highway police department conducted a survey and clocked the speeds of number of cars on a highway. The following distribution was obtained:

Speed below (in kms/hour)	Number of cars
65	19
70	44
75	99
80	184
85	194
90	200

Compute the speed (in kms / hour) below which 75% cars have their speed.

Solution: First, construct classes and frequency table as follows:

Speed (in km / hour)	Number of cars	Less than cumulative frequency
Below 65	19	19
65-70	44-□ = 34	44
□-□	□-□ = 55	99
□-□	□-□ = □	184 ← Q_3
80-85	□-□ = 10	194
85-90	□-□ = □	200

Compute the speed in km/hour below which 75% cars have their speed that is, we have to calculate the value of Q_3 .

$$\text{Here } N = \sum f = \square$$

$$\left(\frac{3N}{4} \right) = 150$$

∴ Q_3 lies in the class 75-80

$$L = \square, c.f. = 99, h = 5, f = \square$$

$$Q_3 = L + \frac{h}{f} \left(\frac{3N}{4} - c.f. \right)$$

$$Q_3 = 75 + \frac{5}{85} (-99)$$

$$Q_3 = 75 + \frac{255}{85}$$

$$Q_3 = 75 + 3$$

$$Q_3 = \square$$

∴ There are 75% cars passing the highway with speed less than 78 km per hour.

Note : 1) For partition values it is not mandatory to convert discontinuous classes into continuous form. The answer may differ by some decimal figure, which is still correct.

2) If the missing frequency value is in decimal, then approximate it to nearest whole number.

Ex.5: For the following frequency distribution value of Q_2 is 22, find the missing frequency.

Class	Frequency
0.5-9.5	5
10.5-19.5	8
20.5-29.5	?
30.5-39.5	4
40.5-49.5	3

Solution: Let us make the classes continuous and assume that x is a missing frequency. Less than cumulative frequency table is given as follows:

Class	Frequency	Less than cumulative frequency
0-10	5	5
<input type="text"/> - <input type="text"/>	8	<input type="text"/>
<input type="text"/> - <input type="text"/>	x	$13+x \leftarrow$
30-40	4	<input type="text"/>
<input type="text"/> - <input type="text"/>	3	<input type="text"/>

Here, 2nd quartile (Q_2) = 22

Therefore 20-30 is the second quartile class, Q_2 is given by

$$Q_2 = L + \frac{h}{f} \left(\frac{N}{2} - c.f. \right)$$

$$L = \text{input}, c.f. = \text{input}, h = \text{input}, f = x, \\ N = 20 + x$$

$$Q_2 = 20 + \frac{10}{x} \left(\frac{20+x}{2} - 13 \right)$$

$$Q_2 = 20 + \frac{10}{x} \left(10 + \frac{x}{2} - 13 \right)$$

$$Q_2 = 20 + \frac{10}{x} \left(\frac{x}{2} - 3 \right)$$

$$Q_2 = 20 + 5 - \frac{30}{x}$$

$$22 = 20 + 5 - \frac{30}{x}$$

$$-3 = -\frac{30}{x}$$

$$= 10$$

Therefore, the missing frequency is 10.

Ex.6: The following is the distribution of monthly sales of 50 shops on a certain street in a city:

Sales in ₹ ('000)	No. of shops
0-10	3
10-20	?
20-30	20
30-40	12
40-50	?

If the value of Q_1 is 20.75 and two frequencies are missing, find the missing frequencies.

Solution: Here, assume that a and b are missing frequencies. Less than cumulative frequency table is given as follows:

Sales in ₹ ('000)	No. of shops	Less than cumulative frequency
0-10	3	3
10-20	a	$3+a$
20-30	20	$23+a \leftarrow Q_1$
30-40	12	$35+a$
40-50	b	$35+a+b$
Total	$35+a+b$	-

Since total frequency = 50

$$\text{i.e. } a + b + 35 = 50$$

$$a + b = 15 \quad \dots(1)$$

We have given that $Q_1 = 20.75$

20-30 is the first quartile class

Q_1 is given by

$$Q_1 = L + \frac{h}{f} \left(\frac{N}{4} - c.f. \right)$$

$$L = 20, c.f. = 3+a, h = 10, f = 20, N = 50$$

$$Q_1 = 20 + \frac{10}{20} \left(\frac{50}{4} - 3 - a \right)$$

$$20.75 = 20 + \frac{1}{2} (12.5 - 3 - a)$$

$$20.75 - 20 = \frac{1}{2} (9.5 - a)$$

$$0.75 = \frac{1}{2} (9.5 - a)$$

$$1.5 = 9.5 - a$$

$$a = 9.5 - 1.5$$

$$a = 8$$

By putting the value of 'a' in equation (1), we get, $b = 7$

The missing frequencies are 8 and 7 respectively.

EXERCISE 1.1

1. Compute all the quartiles for the following series of observations :
16, 14.9, 11.5, 11.8, 11.1, 14.5, 14, 12, 10.9, 10.7, 10.6, 10.5, 13.5, 13, 12.6.
2. The heights (in cm.) of 10 students are given below :
148, 171, 158, 151, 154, 159, 152, 163, 171, 145.
Calculate Q_1 and Q_3 for the above data.
3. Monthly consumption of electricity (in units) of families in a certain locality is given below :
205, 201, 190, 188, 195, 172, 210, 225, 215, 232, 260, 230.

Calculate electricity consumption (in units) below which 25% of families lie.

4. For the following data of daily expenditure of families (in ₹), compute the expenditure below which 75% of families include their expenditure.

Daily Expenditure (in ₹)	350	450	550	650	750
No. of families	16	19	24	28	13

5. Calculate all the quartiles for the following frequency distribution :

No. of E-transactions per day	0	1	2	3	4	5	6	7
No. of days	10	35	45	95	64	32	10	9

6. The following is the frequency distribution of heights of 200 male adults in a factory :

Height in cm.	No. of male adults
145-150	4
150-155	6
155-160	25
160-165	57
165-170	64
170-175	30
175-180	8
180-185	6

Find the central height.

7. The following is the data of pocket expenditure per week of 50 students in a class. It is known that the median of the distribution is ₹120. Find the missing frequencies.

Expenditure per week (in ₹)	0-50	50-100	100-150	150-200	200-250
No. of students	7	?	15	?	3

8. The following is the distribution of 160 workers according to the wages in a certain factory :

Wages more than (in ₹)	No. of workers
8000	160
9000	155
10000	137
11000	91
12000	57
13000	23
14000	10
15000	1
16000	0

Determine the values of all quartiles and interpret the results.

9. Following is grouped data for duration of fixed deposits of 100 senior citizens from a certain bank :

Fixed deposits (in days)	0-180	180-360	360-540	540-720	720-900
No. of senior citizens	15	20	25	30	10

Calculate the limits of fixed deposits of central 50% senior citizens.

10. Find the missing frequency given that the median of distribution is 1504.

Life in hours	950-1150	1150-1350	1350-1550	1550-1750	1750-1950	1950-2150
No. of bulbs	20	43	100	-	23	13

1.3 Deciles and Percentiles:



Let's Learn

Deciles:

Deciles are values, which divide the observations in 10 equal parts when arranged in ascending order of magnitude

Deciles are denoted by D_1, D_2, \dots, D_9

The formula of deciles for raw data is given below:

$$i^{\text{th}} \text{ Decile} = D_i = \text{Value of observation, } \left[i \left(\frac{n+1}{10} \right) \right]^{\text{th}}$$

$$i = 1, 2, \dots, 9$$

Note:- If the above value is not an integer then use the method explained in calculation of Quartiles. (Refer page no. 4).

The formula of deciles for grouped data is,

$$D_i = L + \frac{h}{f} \left(\frac{iN}{100} - c.f. \right), \quad i = 1, 2, \dots, 9$$

Here L = lower boundary of i^{th} decile class

h = class width of i^{th} decile class

f = frequency of decile class

$c.f.$ = less than cumulative frequency of the class preceding i^{th} decile class

N = total frequency



Let's Learn

Percentiles:

Percentiles are values which divide observations in 100 equal parts when they are arranged in ascending order of magnitude. Percentiles are denoted by P_1, P_2, \dots, P_{99} .

The formula of percentiles for raw data is given below:

$$i^{\text{th}} \text{ Percentile} = P_i = \text{Value of observation, } \left[i \left(\frac{n+1}{100} \right) \right]^{\text{th}}$$

$$i = 1, 2, \dots, 99.$$

Note:- If the above value is not an integer then use the method explained in calculation of Quartiles. (Refer page no. 3).

The formula of percentile for grouped data is,

$$P_i = L + \frac{h}{f} \left(\frac{iN}{100} - c.f. \right), 1, 2, \dots, 99$$

Here, L = lower boundary of i^{th} percentile class

h = class width of i^{th} percentile class

f = frequency of i^{th} percentile class

$c.f.$ = less than cumulative frequency of the class just preceding i^{th} percentile class

N = total frequency



Let's Learn

Relations among quartiles, deciles and percentiles:

From definition it can be seen that,

(1) $Q_2 = D_5 = P_{50}$

(2) $Q_1 = P_{25}$

(3) $Q_3 = P_{75}$



Let's Think

Can you find $D_1 = P_{\square}$, $P_{30} = D_{\square}$,
 $D_{\square} = P_{70}$?

SOLVED EXAMPLES

Ex.1: Calculate 3rd decile and 70th percentile for the following data:

841, 289, 325, 225, 784, 729, 625, 400, 324, 169.

Solution: First, we arrange the data in ascending order as follows:

169, 225, 289, 324, 325, 400, 625, 729, 784, 841

Here, $n = 10$

$$D_3 = \text{Value of } \left[3 \left(\frac{10+1}{10} \right) \right]^{\text{th}} \text{ observation}$$

$$= \text{value of } 3.3^{\text{rd}} \text{ observation}$$

$$= \text{value of } 3^{\text{rd}} \text{ observation} + 0.3$$

(value of 4th observation – value of 3rd observation)

$$= 289 + 0.3 (324 - 289)$$

$$D_3 = 299.5$$

$$P_{70} = \text{Value of } \left[70 \left(\frac{10+1}{100} \right) \right]^{\text{th}} \text{ observation}$$

$$= \text{value of } 7.7^{\text{th}} \text{ observation}$$

$$= \text{value of } 7^{\text{th}} \text{ observation} + 0.7$$

(value of 8th observation – value of 7th observation)

$$= 625 + 0.7 (729 - 625)$$

$$= 625 + 72.8$$

$$P_{70} = 697.8$$

Ex.2: Find D_4 and P_{55} for the following data:

No. of defective Products	30	35	40	45	50	55	60
No. of firms	12	35	10	15	8	7	8

Solution: Prepare less than cumulative frequency table as below:

No. of defective products	No. of firms	Less than cumulative frequency
30	12	12
35	35	47 ← D_4
40	10	57 ← P_{55}
45	15	72

50	8	80
55	7	87
60	8	95

$$n = 95$$

$$D_4 = \text{Value of } \left[4 \left(\frac{95+1}{10} \right) \right]^{\text{th}} \text{ observation}$$

$$= \text{value of } 38.4^{\text{th}} \text{ observation}$$

$$D_4 = 35$$

$$P_{55} = \text{Value of } \left[55 \left(\frac{95+1}{100} \right) \right]^{\text{th}} \text{ observation}$$

$$= \text{value of } 52.8^{\text{th}} \text{ observation}$$

$$P_{55} = 40$$

Ex.3: Calculate the 4th decile and 21st percentile from the following data:

Profit (in lakh ₹)	0.5- 4.5	5.5- 9.5	10.5- 14.5	15.5- 19.5	20.5- 24.5
No. of firms	7	18	25	30	20

Solution: Make the classes continuous and construct less than cumulative frequency table as follows:

Profit (in lakh ₹)	Number of firms (f)	Less than cumula- tive frequency
0-5	7	7
<input type="text"/> - <input type="text"/>	18	25 ← P_{21}
<input type="text"/> - <input type="text"/>	25	50 ← D_4
15-20	30	<input type="text"/>
<input type="text"/> - <input type="text"/>	20	<input type="text"/>

$$D_4 = \text{Value of } \left[4 \left(\frac{100}{10} \right) \right]^{\text{th}} \text{ observation}$$

$$D_4 = \text{value of } 40^{\text{th}} \text{ observation}$$

D_4 lies in the class 10-15

L = lower boundary of fourth decile class =

h = class width of fourth decile class
=

f = frequency of fourth decile class
=

$c.f.$ = less than cumulative frequency of the class preceding fourth decile class =

N = total frequency =

$$D_4 = L + \frac{h}{f} \left(\frac{4N}{10} - c.f. \right)$$

$$= 10 + \frac{5}{25} \left(\frac{4 \times 100}{10} - 25 \right)$$

$$= 10 + \frac{5}{25} (40 - 25)$$

$$= 10 + 3$$

$$D_4 = 13$$

For percentile

$$P_{21} = \text{Value of } \left(\frac{21 \times 100}{100} \right)^{\text{th}} \text{ observation}$$

$$= \text{value of } 21^{\text{st}} \text{ observation}$$

P_{21} lies in the class 5-10

L = lower boundary of 21st percentile class =

h = class width of 21st percentile class
=

f = frequency of 21st percentile class
=

$c.f.$ = less than cumulative frequency of the class preceding 21st percentile =

N = total frequency = 100

$$P_{21} = L + \frac{h}{f} \left(\frac{21N}{100} - c.f. \right)$$

$$= 5 + \frac{5}{18} \left(\frac{21 \times 100}{100} - \text{$$

$$= 5 + \frac{5}{18}(21-7)$$

$$= 5 + \frac{70}{18}$$

$$= 5 + 3.89$$

$$P_{21} = 8.89$$

Ex.4: A study related to the journey of office files through various departments was conducted. The distribution of time (in months) taken by a file to come back to the initiating department is given below:

Time	1-2	2-3	3-4	4-5	5-6	6 and above
No. of files	30	45	40	50	6	4

Find: (a) the time by which 75% of the files come back.

(b) the time by which at most 60% of the files come back.

Solution: Construct less than cumulative frequency table as follows:

Time (in months)	Number of files (f)	Less than cumulative frequency
1-2	30	<input type="text"/>
2-3	45	<input type="text"/>
3-4	40	115 $\leftarrow P_{60}$
4-5	50	165 $\leftarrow P_{75}$
5-6	6	<input type="text"/>
6 and above	4	<input type="text"/>

To find the time by which 75% of the files come back i.e. we have to find the value of P_{75}

$$P_{75} = \text{value of } \left(\frac{75 \times 175}{100} \right)^{\text{th}} \text{ observation}$$

$$= \text{value of } 131.25^{\text{th}} \text{ observation}$$

P_{75} lies in the class 4-5

L = lower boundary of 75th percentile class =

h = class width of 75th percentile class =

f = frequency of 75th percentile class =

c.f. = less than cumulative frequency of the class preceding 75th percentile =

N = total frequency =

$$P_{75} = L + \frac{h}{f} \left(\frac{75N}{100} - c.f. \right)$$

$$= \text{} + \frac{1}{50} \left(\frac{75 \times 175}{100} - \text{} \right)$$

$$= 4 + \frac{1}{50} (131.25 - 115)$$

$$= 4 + \frac{16.25}{50}$$

$$= 4 + 0.325$$

$$P_{75} = 4.325$$

Thus the time by which 75% of the files come back is 4.325 months.

We have to find the time by which at most 60% of the files come back. that is we have to find P_{60}

For 60th percentile

$$P_{60} = \text{value of } \left(\frac{60 \times 175}{100} \right)^{\text{th}} \text{ observation}$$

$$P_{60} = \text{value of } 105^{\text{th}} \text{ observation}$$

P_{60} lies in the class 3-4

L = lower boundary of 60th percentile class =

h = class width of 60th percentile class =

f = frequency of 60th percentile class =

$c.f.$ = less than cumulative frequency of the class preceding 60th percentile =

N = total frequency = 175

$$P_{60} = L + \frac{h}{f} \left(\frac{60N}{100} - c.f. \right)$$

$$= \text{} + \frac{1}{40} \left(\frac{60 \times 175}{100} - 75 \right)$$

$$= 3 + \frac{1}{40} (105 - 75)$$

$$= 3 + \frac{30}{40}$$

$$= 3 + 0.75$$

$$P_{60} = 3.75$$

Thus the time by which at most 60% of the files come back is 3.75 months.

Ex.5: Following is the frequency distribution of number of days when students were absent in a particular class:

Number of days absent	No. of students
Below 10	15
Below 20	35
Below 30	60
Below 40	84
Below 50	106
Below 60	120
Below 70	125

Calculate D_6 and P_{30} for the above data.

Solution: Convert the data in groups and construct less than cumulative frequency table as follows:

Number of days absent	Number of students (f)	Less than cumulative frequency
<input type="text"/> - <input type="text"/>	15	15
10-20	<input type="text"/>	35
<input type="text"/> - <input type="text"/>	25	60 ← P_{30}
30-40	<input type="text"/>	84 ← D_6
<input type="text"/> - <input type="text"/>	22	106
50-60	<input type="text"/>	120
<input type="text"/> - <input type="text"/>	5	125

$$D_6 = \text{value of } \left(\frac{6 \times 125}{10} \right)^{\text{th}} \text{ observation}$$

$$= \text{value of } 75^{\text{th}} \text{ observation}$$

D_6 lies in the class 30-40

L = lower boundary of sixth decile class =

h = class width of sixth decile class =

f = frequency of sixth decile class =

$c.f.$ = less than cumulative frequency of the class preceding 6th decile =

N = total frequency =

$$D_6 = L + \frac{h}{f} \left(\frac{6N}{10} - c.f. \right)$$

$$= \text{} + \frac{10}{24} \left(\frac{6 \times 125}{10} - 60 \right)$$

$$= 30 + \frac{10}{24} (75 - 60)$$

$$= 30 + \frac{150}{24}$$

$$= 30 + 6.25$$

$$D_6 = 36.25$$

i.e. 60% students are absent for less than 36 days.

$$P_{30} = \text{value of } \left(\frac{30 \times 125}{100} \right)^{\text{th}} \text{ observation}$$

P_{30} = value of 37.5th observation

P_{30} lies in the class

L = lower boundary of 30th percentile class = 20

h = class width of 30th percentile class = 10

f = frequency of 30th percentile class = 25

c.f. = less than cumulative frequency of the class preceding 30th percentile class = 35

N = total frequency = 125

$$P_{30} = L + \frac{h}{f} \left(\frac{30N}{100} - c.f. \right)$$

$$= \square + \frac{10}{25} \left(\frac{30 \times 125}{100} - \square \right)$$

$$= 20 + \frac{10}{25} (37.5 - 35)$$

$$= 20 + \frac{10 \times 2.5}{25}$$

$$= 20 + 1$$

$$P_{30} = 21$$

i.e. 30% students are absent for less than 21 days.

Ex.6: Following is the distribution of marks in Statistics obtained by 50 students

Marks	No. of students
More than 0	50
More than 10	46
More than 20	40
More than 30	20
More than 40	10
More than 50	3

If 60% students passed the examination, find the minimum marks required to pass examination.

Solution: Construct the frequency and less than cumulative frequency table as follows:

Marks	Number of students (f)	Less than cumulative frequency
<input type="text"/> - <input type="text"/>	4	4
<input type="text"/> - <input type="text"/>	<input type="text"/>	10
20-30	30-10=20	30 ← P_{40}
<input type="text"/> - <input type="text"/>	<input type="text"/>	40
<input type="text"/> - <input type="text"/>	<input type="text"/>	47
50-60	<input type="text"/>	50

In order to find the minimum marks obtained by a passed student if 60% students passed, 40% will fail in the examination. So minimum marks required for passing is to cross P_{40} .

$$P_{40} = \text{value of } \left(\frac{40 \times 50}{100} \right)^{\text{th}} \text{ observation}$$

$$= \text{value of } 20^{\text{th}} \text{ observation}$$

P_{40} lies in the class

L = lower boundary of 40th percentile class =

h = class width of 40th percentile class =

f = frequency of 40th percentile class = 20

c.f. = less than cumulative frequency of the class preceding 40th percentile =

N = total frequency =

$$= L + \frac{h}{f} \left(\frac{40N}{100} - c.f. \right)$$

$$= \square + \frac{10}{20} \left(\frac{40 \times 50}{100} - 10 \right)$$

$$= 20 + \frac{10}{20} (20 - 10)$$

$$= 20 + \frac{100}{20}$$

$$= 20 + 5$$

$$P_{40} = 25$$

Hence if 60% students pass the test, the minimum marks for passing of a candidate should be 25.

Ex.7: Following is the distribution of age of 500 workers, find the percentage of workers whose age is more than 45 years.

Age	20-30	30-40	40-50	50-60
No. of workers	80	160	180	80

Solution: construct the frequency and less than cumulative frequency table

Class Interval	Frequency (f)	Less than cumulative frequency ($l.c.f.$)
20-30	80	<input type="text"/>
30-40	160	<input type="text"/>
40-50	180	$420 \leftarrow P_x$
50-60	80	500

Since, $P_x = 45$ lies in the class 40-50

L = lower boundary of P_x class = 40

h = class width of P_x class = 10

f = frequency of P_x class = 180

$c.f.$ = less than cumulative frequency of the class preceding P_x class = 240

N = total frequency = 500

$$P_x = L + \frac{h}{f} \left(\frac{xN}{100} - c.f. \right)$$

$$45 = 40 + \frac{10}{180} \left(\frac{x \times 500}{100} - 240 \right)$$

$$45 - 40 = \frac{10}{180} \left(\frac{x \times 500}{100} - 240 \right)$$

$$\frac{180 \times 5}{10} = \left(\frac{x \times 500}{100} - 240 \right)$$

$$90 + 240 = 5x$$

$$330 = 5x$$

$$x = 66$$

66% workers have age below 45 years and 34% workers have age more than 45 years.

Alternative Method:

Above example can also be solved by the following method. Since the percentage of workers having age more than 45 years is required, we find the class in which '45' lies. Clearly '45' lies in the class 40-50. The class 40-50 is divided by 45 as 40-45 and 45-50. The ratio of width of these subclasses is 5: 5, i.e. 1: 1. Hence, the frequency of the class 40-50 which is 180 should be divided in the ratio 1: 1. So the number of workers in both the subclasses is 90.

Hence, the number of workers having age above 45 is $90 + 80 = 170$.

$$\text{Their required percentage} = \frac{170}{500} \times 100 = 34.$$

34% workers have age more than 45 years.

Ex.8: If the 2nd decile of the distribution given below is 13.75, find the missing value.

Mid points	5	15	25	35	45
Frequency	2	?	10	3	2

Solution: construct the frequency and less than cumulative frequency table

Class Interval	Frequency f	Less than cumulative frequency
0-10	2	2
10-20	x	$2 + x \leftarrow D_2$

20-30	10	$12 + x$
30-40	3	$15 + x$
40-50	2	$17 + x$

D_2 is 13.75 lies in the class 10-20

L = lower boundary of 2nd decile class = 10

h = class width of 2nd decile class = 10

f = frequency of 2nd decile class = x

c.f. = less than cumulative frequency of the class preceding 2nd decile class = 2

N = total frequency = $17 + x$

$$D_2 = L + \frac{h}{f} \left(\frac{2N}{10} - c.f. \right)$$

$$= 10 + \frac{10}{x} \left(\frac{2(17+x)}{10} - 2 \right)$$

$$13.75 = 10 + \frac{10}{x} \left(\frac{34+2x}{10} - 2 \right)$$

$$13.75 - 10 = \frac{10}{x} \left(\frac{34+2x}{10} - 2 \right)$$

$$\frac{3.75x}{10} + 2 = \frac{34+2x}{10}$$

$$3.75x + 20 = 34 + 2x$$

$$1.75x = 14$$

$$x = 8$$

The missing value is 8.

EXERCISE 1.2

- Calculate D_6 and P_{85} for the following data :
79,82,36,38,51,72,68,70,64,63
- The daily wages (in ₹) of 15 laboures are as follows :
230,400,350,200,250,380,210,225,375,180,
375,450,300,350,250
Calculate D_8 and P_{90}

- Calculate 2nd decile and 65th percentile for the following :

x	80	100	120	145	200	280	310	380	400	410
f	15	18	25	27	40	25	19	16	8	7

- From the following data calculate the rent of 15th, 65th & 92nd house.

House Rent (in ₹)	11000	12000	13000	15000	14000	16000	17000	18000
No. of houses	25	17	13	14	15	8	6	2

- The following frequency distribution shows the weight of students in a class.

Weight (in Kg)	40	45	50	55	60	65
Number of Students	15	40	29	21	10	5

- Find the percentage of students whose weight is more than 50 kg.
 - If the weight column provided is of mid values then find the percentage of students whose weight is more than 50 kg.
- Calculate D_4 and P_{48} from the following data:

Mid Value	2.5	7.5	12.5	17.5	22.5	Total
Fre-quency	7	18	25	30	20	100

- Calculate D_9 and D_{20} of the following distribution.

Length (in Inches)	0-20	20-40	40-60	60-80	80-100	100-120
No. of units	1	14	35	85	90	15

8. Weekly wages for group of 100 persons are given below :

Wages (in ₹)	0-500	500-1000	1000-1500	1500-2000	2000-2500
No. of persons	7	?	25	30	?

D_3 for this group is ₹ 1100 Calculate the missing frequencies.

9. The weekly profit (in rupees) of 100 shops are distributed as follows :

Profit per shop	No. of Shops
0-1000	10
1000-2000	16
2000-3000	26
3000-4000	20
4000-5000	20
5000-6000	5
6000-7000	3

Find the limits of the profit of middle 60% of the shops.

10. In a particular factory, workers produce various types of output units

The following distribution was obtained

Outputs units Produced	No. of workers
70-74	40
75-79	45
80-84	50
85-89	60
90-94	70
95-99	80
100-104	100

Find the percentage of workers who have produced less than 82 output units.



Let's Learn

1.4 Graphical location of partition values:

We have already studied how to determine partition values by numerical methods. Now, let us study a graphical method to determine partition values of grouped frequency distributions.

- (i) Ogive is a cumulative frequency curve. Since there are two types of cumulative frequencies, there are two types of ogives, namely less than ogive (less than type cumulative curve) and more than ogive (more than type cumulative curve).

(a) To draw less than ogive :

Step 1 : Compute less than cumulative frequencies (lcf) for the given frequency distribution. Assign zero lcf for the preceding class of the first class

Step 2 : Take upper class boundaries on the X-axis and lcf on the Y-axis on XY-plane

Step 3 : Plot the points (x,y) where x = upper class boundary, $y = cf$, for all classes.

Step 4 : Join these points by a smooth free hand curve. This curve is called "less than ogive".

(b) To draw more than ogive :

Step 1 : Compute more than cumulative frequencies (mcf) for the given frequency distribution. Assign zero mcf for the succeeding class of the last class.

Step 2 : Take lower boundaries on the X-axis and mcf on the Y-axis XY-plane.

Step 3 : Plot the points (x,y) , (x = lower class boundary, $y = mcf$) for all classes.

Step 4 : Join these points by a smooth free hand. This is called more than ogive.

(ii) Locate $\frac{N}{2}$ on the Y-axis and draw a

line parallel to X-axis from this point, meeting the ogive at a point say P. Draw a perpendicular to X-axis from P. Median is the value at the foot of perpendicular.

Similarly, other partition values can also be located.

i^{th} quartile (Q_i) is determined by drawing a line parallel to X-axis from $y = i \frac{N}{4}$

i^{th} decile (D_i) is obtained by drawing a line parallel to X-axis from $y = i \frac{N}{10}$

i^{th} percentile (P_i) is obtained by drawing line parallel to X-axis from $y = i \frac{N}{100}$.

Remarks:

(1) An alternative method of determining median by graphical method is as follows:

Draw both types of ogives on the same graph paper. The perpendicular to X-axis drawn from the point of intersection of two ogives meets it at the median.

(2) The graphical method may not give exact partition values. The values obtained by graphical method are approximate.

SOLVED EXAMPLES

Ex. 1: For the following data of marks in Statistics, determine, Q_2 , D_8 and P_{60} graphically.

Marks	0-10	10-20	20-30	30-40	40-50	50-60
Frequency	4	6	20	10	7	3

Solution:

Marks	Frequency	Less than cumulative-Frequency
0-10	4	4
10-20	6	10
20-30	20	30
30-40	10	40
40-50	7	47
50-60	3	50

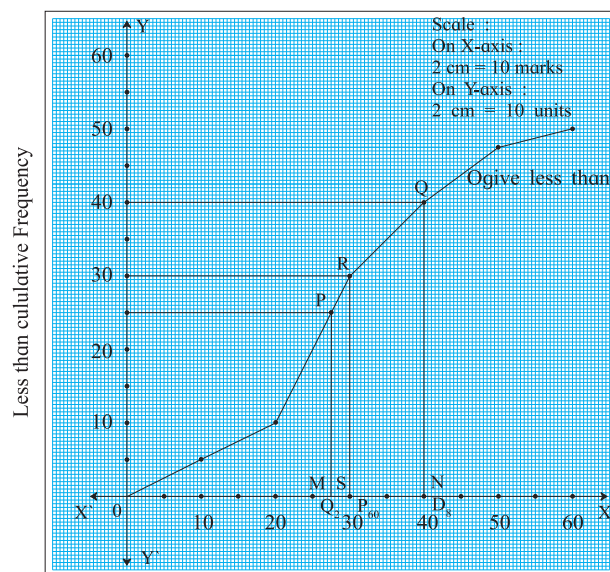

Upper class boundaries

Fig. 1.2

Plotting the less than cumulative frequency against the corresponding upper class boundaries and joining these points by a smooth curve, we get less than ogive as shown in figure 1.2

(i) At the frequency $\frac{N}{2} = \frac{50}{2} = 25$, draw a line parallel to X-axis as shown in fig. 1.2

Then $OM = 27.5$ is the Q_2 marks.

(ii) At the frequency $\frac{8N}{10} = \frac{8 \times 50}{10} = 40$, draw a line parallel to X-axis as shown in fig. 1.2

Then, $D_8 = ON = 40$

Similarly $P_{60} = OS = 30$

Ex.2: The following distribution gives the pattern of overtime work per week done by 100 employees of a company. Calculate median, first quartile and seventh decile graphically. Also estimate numbers of employees who worked less than 11 hours per week.

Overtime (in hours)	No. of employees
10-14	11
15-19	20
20-24	35
25-29	20
30-34	8
35-39	6

Solution: Here the class intervals are discontinuous.

Convert the class intervals into continuous classes

Marks	Frequency	Less than cumulative frequency
9.5-14.5	11	11
14.5-19.5	20	31
19.5-24.5	35	66
24.5-29.5	20	86
29.5-34.5	8	94
34.5-39.5	6	100

Plotting upper class boundaries against less than cumulative frequencies, we get ogive as shown in the figure 1.3

To find out median, Q_1 and P_{70} graphically, draw lines parallel to X-axis from frequencies

$\frac{N}{2}$, $\frac{N}{4}$ and $\frac{7N}{10}$ respectively. Draw

perpendiculars on X-axis from P, Q and R.

Then $Q_1 = OL = 18$

Median = $OM = 23$ approximately

$P_{70} = ON = 25$ approximately

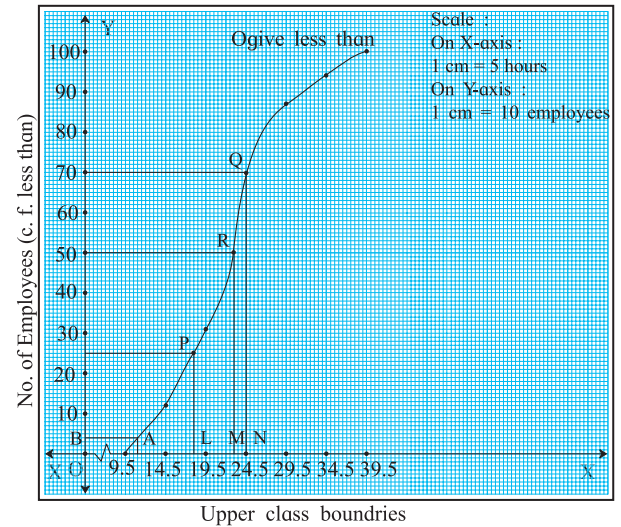

Fig. 1.3

To find number of employees who worked less than 11 hours per week, draw a line parallel to Y-axis from upper class boundaries equal to 11 which meets the curve in A. Draw perpendicular AB on Y-axis. Read the value at the foot of perpendicular namely B.

The number of workers who worked less than 11 hours = $OB = 4$



Let's Think

Can you solve above problem by drawing more than ogive?

EXERCISE 1.3

1. The following table gives frequency distribution of marks of 100 students in an examination.

Marks	15-20	20-25	25-30	30-35	35-40	40-45	45-50
No. of students	9	12	23	31	10	8	7

Determine D_6 , Q_1 and P_{85} graphically.

2. The following table gives the distribution of daily wages of 500 families in a certain city.

Daily wages	No. of families
Below 100	50
100-200	150
200-300	180
300-400	50
400-500	40
500-600	20
600 above	10

Draw a 'less than' ogive for the above data. Determine the median income and obtain the limits of income of central 50% of the families.

3. From the following distribution, determine median graphically.

Daily wages (in ₹)	No. of employees
Above 300	520
Above 400	470
Above 500	399
Above 600	210
Above 700	105
Above 800	45
Above 900	7

4. The following frequency distribution shows the profit (in ₹) of shops in a particular area of city.

Profit per shop (in '000)	No. of shops
0-10	12
10-20	18
20-30	27
30-40	20
40-50	17
50-60	6

Find graphically

- The limits of middle 40% shops.
- The number of shops having profit less than 35,000 rupees.

5. The following is frequency distribution of over time (per week) performed by various workers from a certain company.

Determine the values of D_2 , Q_2 and P_{61} graphically.

Overtime (in hours)	Below 8	8-12	12-16	16-20	20-24	24 and above
No. of workers	4	8	16	18	20	14

6. Draw ogive for the following data and hence find the values of D_1 , Q_1 , P_{40} .

Marks less than	10	20	30	40	50	60	70	80	90
No. of students	4	6	24	46	67	86	96	99	100

7. The following table shows the age distribution of head of the families in a certain country. Determine the third, fifth and eighth decile of the distribution graphically.

Age of head of family (in years)	Numbers (million)
Under 35	46
35-45	85
45-55	64
55-65	75
65-75	90
75 & Above	40

8. The following table gives the distribution of females in an Indian village. Determine the median age graphically.

Age group	0-10	10-20	20-30	30-40	40-50	50-60	60-70	70-80	80-90	90-100
No. of females (in '000')	175	100	68	48	25	50	23	8	2	1

9. Draw ogive for the following distribution and hence find graphically the limits of weight of middle 50% fishes.

Weight of fishes (in gms)	800-890	900-990	1000-1090	1100-1190	1200-1290	1300-1390	1400-1490
No. of fishes	8	16	20	25	40	6	5

10. Find graphically the values of D_3 and P_{65} for the data given below :

I.Q. of students	60-69	70-79	80-89	90-99	100-109	110-119	120-129
No. of students	20	40	50	50	20	10	10



Let's Remember

- Partition values divide the given distribution into a number of equal parts.
- Quartiles, deciles and percentiles divide the distribution into 4, 10, and 100 equal parts respectively.
- The formulae for raw data:

$$i^{\text{th}} \text{ Quartile} = Q_i = \text{value of } \left[i \left(\frac{n+1}{4} \right) \right]^{\text{th}} \text{ observation,}$$

$$i^{\text{th}} \text{ Decile} = D_i = \text{value of } \left[i \left(\frac{n+1}{10} \right) \right]^{\text{th}} \text{ observation,}$$

$$i^{\text{th}} \text{ Percentile} = P_i = \text{value of } \left[i \left(\frac{n+1}{100} \right) \right]^{\text{th}} \text{ observation,}$$

- The formulae for grouped continuous data :

$$Q_i = L + \frac{h}{f} \left(\frac{iN}{4} - c.f. \right), \quad i = 1, 2, 3$$

$$D_i = L + \frac{h}{f} \left(\frac{iN}{10} - c.f. \right), \quad i = 1, 2, 3, \dots, 9$$

$$P_i = L + \frac{h}{f} \left(\frac{iN}{100} - c.f. \right), \quad i = 1, 2, \dots, 99$$

- Approximate partition values can be determined by using ogive.
- Median = $Q_2 = D_5 = P_{50}$

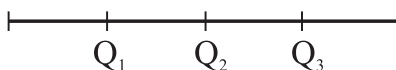
Quartiles 

$$Q_1 < Q_2 < Q_3$$

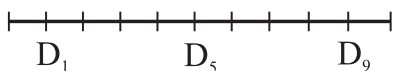
Deciles 

$$D_1 < D_2 < D_3 < \dots < D_9$$

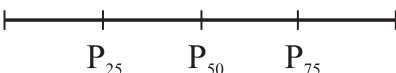
Percentiles 

$$P_1 < P_2 < P_3 < \dots < P_{99}$$

MISCELLANEOUS EXERCISE

1. The data gives number of accidents per day on a railway track Compute Q_2 , P_{17} and D_7 .
4,2,3,5,6,3,4,1,2,3,2,3,4,3,2.
2. The distribution of daily sales of shoes (size wise) for 100 days from a certain shop is :

Size of shoes	2	4	3	5	7	6	8
No. of days	14	20	13	19	13	13	8

Compute Q_1 , D_2 and P_{95} .

3. Ten students appeared for a test in Mathematics and Statistics and they obtained the marks as follows:

Sr. No.	1	2	3	4	5	6	7	8	9	10
Marks in Mathematics	42	38	36	32	23	25	35	37	25	23
Marks in Statistics	22	26	29	34	50	45	23	28	32	36

If the median will be the criteria, in which subject, the level of knowledge of the students is higher?

4. In the frequency distribution of families given below, the number of families corresponding to expenditure groups 2000-4000 is missing from the table. However value of 25th percentile is 2880. Find the missing frequency.

Weekly Expenditure (₹ 1000)	0-2	2-4	4-6	6-8	8-10
No. of families	14	?	39	7	15

5. Calculate Q_1 , D_6 and P_{15} for the following data :

Mid value	25	75	125	175	225	275
Frequency	10	70	80	100	150	90

6. Daily income for a group of 100 workers are given below :

Daily Income (in ₹)	0-50	50-100	100-150	150-200	200-250
No. of persons	7	?	25	30	?

P_{30} for this group is ₹ 110. Calculate missing frequencies.

7. The distribution of a sample of students appearing for a C.A. examination is:

Marks	0-100	100-200	200-300	300-400	400-500	500-600
No. of students	130	150	190	220	180	130

Help C.A. institute to decide cut off marks for qualifying the examination when 3% students pass the examination.

8. Determine graphically the value of median, D_3 and P_{35} for the data given below :

Class	10-15	15-20	20-25	25-30	30-35	35-40	40-45
Frequency	8	14	8	25	15	14	6

9. The I.Q. test of 500 students of a college is as follows:

I.Q.	20-30	30-40	40-50	50-60	60-70	70-80	80-90	90-100
Number of students	41	52	64	180	67	45	40	11

Find graphically the number of students whose I.Q. is more than 55 graphically.

10. Draw an ogive for the following distribution. Determine the median graphically and verify your result by mathematical formula.

Height (in cms.)	No. of students
145-150	2
150-155	5
155-160	9
160-165	15
165-170	16
170-175	7
175-180	5
180-185	1

11. In a group of 25 students 7 students failed and 6 students got distinction and the marks of remaining 12 students are 61,36,44,59,52,56,41,37,39,38,41,64. Find the median marks of the whole group.

12. The median weight of a group of 79 students is found to be 55 kg 6 more students are added to this group whose weights are 50,51,52,59.5,60,61kg. What will be the value of median of the combined group if the lowest and the highest weights were 53kg and 59 kg respectively?

13. The median of the following incomplete table is 92. Find the missing frequencies:

C I	30-50	50-70	70-90	90-110	110-130	130-150	Total
f	6	?	18	20	?	10	80

14. A company produces tables which are packed in batches of 100. An analysis of the defective tubes in different batches has received the following information:

No. of defective tubes	Less than 5	5-9	10-14	15-19	20-24	25-29	30 and above
No. of tubes	45	51	84	39	20	8	4

Estimate the number of defective tubes in the central batch.

15. In a college there are 500 students in junior college, 5% score less than 25 marks, 68 score from 26 to 30 marks, 30% score from 31 to 35 marks, 70 score from 36 to 40 marks, 20% score from 41 to 45 marks and the rest score 46 and above marks. What is the median marks?
16. Draw a cumulative frequency curve more than type for the following data and hence locate Q_1 and Q_3 . Also find the number of workers with daily wages

- (i) Between ₹ 170 and ₹ 260
(ii) less than ₹ 260

Daily wages more than (₹)	100	150	200	250	300	350	400	450	500
No. of workers	200	188	160	124	74	49	31	15	5

17. Draw ogive of both the types for the following frequency distribution and hence find median.

Marks	0-10	10-20	20-30	30-40	40-50	50-60	60-70	70-80	80-90	90-100
No. of students	5	5	8	12	16	15	10	8	5	2

18. Find Q_1 , D_6 and P_{78} for the following data :

C.I.	8-8.95	9-9.95	10-10.95	11-11.95	12-12.95
f	5	10	20	10	5

- 19.

Weight (kg)	40-45	45-50	50-55	55-60	60-65	65-70	70-75	75-80
No. of persons	4	15	20	30	20	10	8	4

For above data, find all quartiles and number of persons weighting between 57 kg and 72 kg.

20. For the following data showing weights of 100 employees, find the maximum weight of the lightest 25% of employees.

Weight (kg)	45-50	50-55	55-60	60-65	65-70	70-75	75-80
No. of employees	6	8	15	26	20	14	11

Activity 1.1

Divide the number of students in your class according to their marks in Mathematics in 10th standard in

- (a) 4 equal parts.
(b) 10 equal parts.

Activity 1.2

Find scores in an examination of students in your class.

- (a) The number of students :
- (b) The average marks :
- (c) The median marks :
Who scored the median marks :
- (d) Find the score so that 75% students have scores below it.

Activity 1.3

In a class of 80 students, find number of students with 100% attendance, $< 75\%$ attendance, $< 50\%$ attendance, and $< 25\%$ attendance.

Graphically find the number of students in the black list (that is, have $< 50\%$ attendance)

Activity 1.4

Think and give answer.

If the building is constructed with 114 floors and we need to design six fire exits equally placed on floors of the building. Suggest the floor numbers on which the fire exits can be constructed.



2. MEASURES OF DISPERSION

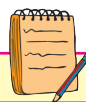

Let's Study

- Meaning and Definition of Dispersion
- Absolute and Relative Measures of Dispersion
- Range of data.
- Inter Quartile Range
- Variance and Standard Deviation
- Coefficient of Variation



Let's Recall

- ✓ Concept of Constant and Variable
- ✓ Concept of an Average
- ✓ Computation of Mean for Ungrouped and Grouped Data
- ✓ Quartiles (Commerce)

“An average does not tell the full story. It is hardly fully representative of a mass unless we know the manner in which the individual items scatter around it. A further description of the series is necessary if we are to gauge how representative the average is.”

- George Simpson and Fritz Kafka

Let's Observe...

In the earlier classes we have learnt about the measures of central tendency namely mean, median and mode. Such an average tells us only about the central part of the data. But it does not give any information about the spread of the

data. For example, consider the runs scored by 3 batsmen in a series of 5 One Day International matches.

Batsman	Runs scored	Total	Mean
X	90, 17, 104, 33, 6	250	50
Y	40, 60, 55, 50, 45	250	50
Z	112, 8, 96, 29, 5	250	50

Table 2.1

All the above series have the same size ($n=5$) and the same mean (50), but they are different in composition. Thus, to decide who is more consistent, the measure of central tendency are not sufficient. We need some other measure. One such measure is that of Dispersion.

In the above example, observations from series X and series Z are more scattered as compared to those in series Y. The scatter in observations is called dispersion. The amount by which the observations deviate from the average is called dispersion.

Let's Construct...

Given two different series-

A : 0.5, 1, 1.5, 3, 4, 8

B : 2, 2.2, 2.6, 3.4, 3.8,

Find arithmetic means of the two series.

Plot the two series on the number line.

Observe the scatter of the data in each series and decide which series is more scattered.



Let's Learn

2.1 Definition :

“The degree to which numerical data tend to spread about an average value is called the **variation** or **dispersion** of the data.”

- Spiegel

Measures of Dispersion :

Following measures of dispersion are the commonly used –

- (i) Range
- (ii) Semi Inter Quartile Range / Quartile Deviation
- (iii) Variance
- (iv) Standard deviation

2.2 Range :

Range is the simplest measure of dispersion. It is defined as the difference between the largest value and the smallest value in the data.

Thus,

$$\text{Range} = \text{Largest Value} - \text{Smallest Value} \\ = L - S$$

Where, L = Largest Value and S = Smallest Value.

SOLVED EXAMPLES

1. Following data gives weights of 10 students (in kgs) in a certain school. Find the range of the data.

70, 62, 38, 55, 43, 73, 36, 58, 65, 47

Solutions : Smallest Value = S = 36

Largest Value = L = 73

Range = L – S = 73 – 36 = 37

2. Calculate range for the following data.

Salary (00's ₹)	30- 50	50- 70	70- 90	90- 110	110- 130	130- 150
No. of Employ- ees	7	15	30	24	18	11

Solution :

L = Upper limit of highest class = 150

S = Lower limit of lowest class = 30

∴ Range = L – S = 150 – 30 = 120



2.3 Quartile Deviation (Semi - Inter Quartile Range) :

We observe the largest and smallest values in the data to find the range. If the data contains extreme values or outliers, then the range is an incorrect measure of variation. In such cases, we use a measure of dispersion based on quartiles to get rid of the effect of the extreme values. This measure is called quartile deviation or Semi-Inter Quartile Range (Semi-IQR) defined as follows.

$$Q. D. = \frac{Q_3 - Q_1}{2} \\ = \frac{\text{Interquartile Range}}{2}$$

Where $Q_3 - Q_1$, is called Interquartile Range.

$$\text{Semi inter quartile range} = \frac{Q_3 - Q_1}{2}$$

SOLVED EXAMPLES

Ex.1. Find Semi Inter Quartile Range for the following data.

Marks of 11 students in Mathematics : 67, 75, 84, 60, 72, 58, 61, 52, 79, 91, 56

Solution : Let us first arrange the given data in ascending order,

52, 56, 58, 60, 61, 67, 72, 75, 79, 84, 91

Here, n=11

$$Q_1 = \left(\frac{n+1}{4} \right)^{\text{th}} \text{ observation}$$

$$= \left(\frac{11+1}{4} \right)^{\text{th}} \text{ observation}$$

$$= 3^{\text{rd}} \text{ observation} = 58$$

$$Q_3 = \left[3 \left(\frac{n+1}{4} \right)^{\text{th}} \right] \text{ observation}$$

$$= \boxed{} \text{ observation}$$

$$= 9^{\text{th}} \text{ observation} = 79$$

$$\therefore \text{Semi Interquartile range} = \frac{Q_3 - Q_1}{2} = \frac{79 - 58}{2} = \frac{21}{2} = 10.5$$

Ex.2. Find an appropriate measure of dispersion for the following data:

In-come (Rs)	Less than 50	50-70	70-90	90-110	110-130	130-150	Above 150
No. of persons	59	102	135	330	200	122	52

Solution:

Since the classes given are with open end intervals, the only measure of dispersion that we can compute the Semi inter quartile range.

Income (in ₹)	No. of persons	Less than c. f.
Less than 50	59	59
50-70	102	161
70-90	125	286
90-110	330	616
110-130	200	816
130-150	132	948
Above 150	52	1000

Table 2.2

Here, $N = 1000$,

$$\therefore \frac{N}{4} = \frac{1000}{4} = 250$$

\therefore The first quartile class is : 70 – 90

$$Q_1 = L + \frac{h}{f} \left(\frac{N}{4} - c.f. \right) = 70 + \frac{20}{125} (250 - 161) = 70 + 14.24 = \text{Rs. } 84.24$$

$$\text{Now, } \frac{3N}{4} = 750$$

\therefore The third quartile class is : 110 – 130

$$Q_3 = L + \frac{h}{f} \left(\frac{3N}{4} - c.f. \right) = 110 + \frac{20}{200} (750 - 616) = 110 + 13.4 = \text{Rs. } 123.4$$

\therefore Semi Inter quartile range

$$= \frac{Q_3 - Q_1}{2} = \frac{123.4 - 84.24}{2} = \frac{39.16}{2} = 19.58$$

EXERCISE 2.1

- Find range of the following data:
575, 609, 335, 280, 729, 544, 852, 427, 967, 250
- The following data gives number of typing mistakes done by Radha during a week. Find the range of the data.

Day	Mon-day	Tues-day	Wedn-esday	Thurs-day	Fri-day	Satur-day
No. of mis-takes	15	20	21	12	17	10

- Find range for the following data.

Classes	62-64	64-66	66-68	68-70	70-72
Frequency	5	3	4	5	3

- Find the Q. D. for the following data.
3, 16, 8, 15, 19, 11, 5, 17, 9, 5, 3.
- Given below are the prices of shares of a company for the last 10 days. Find Q. D.:
172, 164, 188, 214, 190, 237, 200, 195, 208, 230
- Calculate Q. D. for the following data.

X	24	25	26	27	28	29	30
F	6	5	3	2	4	7	3

- Following data gives the age distribution of 250 employees of a firm. Calculate Q. D. of the distribution.

Age (In years)	20-25	25-30	30-35	35-40	40-45	45-50
No. of employees	30	40	60	50	46	14

8. Following data gives the weight of boxes. Calculate Q. D. for the data

Weights (kg.)	10-12	12-14	14-16	16-18	18-20	20-22
No. of boxes	3	7	16	14	18	2
c.f.	3	10	26	40	58	60



Let's Learn

2.5 VARIANCE and STANDARD DEVIATION:

The main drawback of the range and Q. D. is that both are based on only two values, and do not consider all the observations. The variance and standard deviation overcome this drawback as they are based on the deviations taken from the mean.

2.5.1 Variance:

The variance of a variable X is defined as the arithmetic mean of the squares of all deviations of X taken from its arithmetic mean.

It is denoted by $\text{Var}(X)$ or σ^2 .

$$\text{Var}(X) = \sigma^2 = \frac{1}{n} \sum_{i=1}^n (x_i - \bar{x})^2$$

Let's Derive

$$\begin{aligned} \text{We have, } V(X) &= \frac{1}{n} \sum_{i=1}^n (x_i - \bar{x})^2 \\ &= \frac{1}{n} \sum_{i=1}^n (x_i^2 - 2\bar{x}x_i + \bar{x}^2) \\ &= \frac{1}{n} \left[\sum_{i=1}^n x_i^2 + \bar{x}^2 \sum_{i=1}^n 1 - 2\bar{x} \sum_{i=1}^n x_i \right] \\ &= \frac{\sum_{i=1}^n x_i^2}{n} - \frac{2\bar{x} \sum_{i=1}^n x_i}{n} + \frac{\bar{x}^2 \sum_{i=1}^n 1}{n} \\ &= \frac{1}{n} \sum_{i=1}^n x_i^2 + \bar{x}^2 \frac{n}{n} - 2\bar{x} \frac{\sum_{i=1}^n x_i}{n} \end{aligned}$$

$$\begin{aligned} &= \frac{1}{n} \sum_{i=1}^n x_i^2 + \bar{x}^2 - 2\bar{x} \bar{x} \\ &= \frac{1}{n} \sum_{i=1}^n x_i^2 + \bar{x}^2 - 2\bar{x}^2 \\ &= \frac{1}{n} \sum_{i=1}^n x_i^2 - (\bar{x})^2 \end{aligned}$$

2.5.2. Standard Deviation :

Standard Deviation is defined as the positive square root of the variance.

It is denoted by σ (sigma)

(i) Variance and Standard Deviation for raw data :

Let the variable X take the values

$x_1, x_2, x_3, \dots, x_n$.

Let \bar{x} be the arithmetic mean. Then,

$$\text{Var}(X) = \sigma^2 = \frac{1}{n} \sum_{i=1}^n (x_i - \bar{x})^2$$

$$= \frac{\sum_{i=1}^n x_i^2}{n} - \bar{x}^2$$

$$\text{Where } \bar{x} = \frac{\sum_{i=1}^n x_i}{n}$$

$$\text{And S. D.} = \sigma = \sqrt{\text{Var}(X)}$$

(ii) Variance and Standard Deviation for ungrouped frequency distribution :

Let x_1, x_2, \dots, x_n be the values of variable X with corresponding frequencies f_1, f_2, \dots, f_n respectively, then the variance of X is defined as

$$\begin{aligned} \text{Var}(X) = \sigma^2 &= \frac{1}{N} \sum_{i=1}^n f_i (x_i - \bar{x})^2 \\ &= \frac{\sum_{i=1}^n f_i x_i^2}{N} - \bar{x}^2, \end{aligned}$$

SOLVED EXAMPLES

Where, $\bar{x} = \frac{\sum_{i=1}^n f_i x_i}{N}$, and $\sum_{i=1}^n f_i = N = \text{Total frequency}$

$$\text{S. D.} = \sigma = \sqrt{\text{Var}(X)} = + \sqrt{\frac{1}{N} \sum_{i=1}^n f_i x_i^2 - (\bar{x})^2}$$

(iii) Variance and Standard Deviation for grouped frequency distribution :

Let x_1, x_2, \dots, x_n be the mid points and f_1, f_2, \dots, f_n are the corresponding class frequencies, then the Variance is defined as :

$$\begin{aligned} \text{Var}(X) = \sigma^2 &= \frac{1}{N} \sum_{i=1}^n f_i (x_i - \bar{x})^2 \\ &= \frac{\sum_{i=1}^n f_i x_i^2}{N} - \bar{x}^2, \end{aligned}$$

Where $\bar{x} = \frac{\sum_{i=1}^n f_i x_i}{N}$ and $\sum_{i=1}^n f_i = N$
= Total frequency

$$\text{S. D.} = \sigma = \sqrt{\text{Var}(X)} = + \sqrt{\frac{1}{N} \sum_{i=1}^n f_i x_i^2 - (\bar{x})^2}$$

Change of origin and scale:

- The variance and consequently the standard deviation are independent of change of origin.

That is, if $d = X - A$, where A is a constant, then $\sigma_x^2 = \sigma_d^2$.

- The variance and consequently the standard deviation are not independent of change of scale.

Let $u = \frac{X - A}{h}$, where A and h are constants

and $h \neq 0$, then $\sigma_x^2 = h^2 \sigma_u^2$

Ex.1. Compute variance and standard deviation of the following data.

9, 12, 15, 18, 21, 24, 27

Solution :

Here, $n = 7$, $\bar{x} = \frac{\sum_{i=1}^n x_i}{n} = \frac{126}{7} = 18$

x_i	$x_i - \bar{x}$	$(x_i - \bar{x})^2$
9	-9	81
12	-6	36
15	-3	9
18	0	0
21	3	9
24	6	36
27	9	81
126		252

Table 2.3

$$\begin{aligned} \text{Therefore, Var}(X) = \sigma^2 &= \frac{1}{n} \sum_{i=1}^n (x_i - \bar{x})^2 \\ &= \frac{252}{7} = 36 \end{aligned}$$

$$\begin{aligned} \text{S.D.} = \sigma &= \sqrt{\text{Var}(X)} = \sqrt{36} \\ &= 6 \end{aligned}$$

Ex.2. Given below are the marks out of 25 of 5 students of a mathematics test. Calculate the variance and standard deviation of these observations.

Marks : 10, 13, 17, 20, 23

Solution : We use alternate (direct) method to solve this problem.

Calculation of variance :

x_i	x_i^2
10	100
13	169
17	289
20	400
23	529
83	1487

Table 2.4

Here, $n = 5$ and $\bar{x} = \frac{\sum_{i=1}^n xi}{n} = \frac{83}{5} = 16.6$

Therefore, $Var(X) = \sigma^2 = \frac{\sum_{i=1}^n x_i^2 - (\bar{x})^2}{n}$

$$= \frac{1487}{5} - (16.6)^2$$

$$= 297.4 - 275.56$$

$$= 21.84$$

S.D. $= \sigma = \sqrt{Var(X)} = \sqrt{21.84}$

Ex.3. A die is rolled 30 times and the following distribution is obtained. Find the variance and S.D,

Score	1	2	3	4	5	6
Frequency	2	6	2	5	10	5

Solution :

x	f	f.x	x ²	f.x ²
1	2	2	1	2
2	6	12	4	24
3	2	6	9	18
4	5	20	16	80
5	10	50	25	250
6	5	30	36	180
Total	30	120		554

Table 2.5

$N = \sum f = 30$

We get, $\bar{x} = \frac{\sum_{i=1}^n fx}{N} = \frac{120}{30} = 4$

Now, $\sigma_x^2 = \frac{\sum_{i=1}^n fx^2}{N} - \bar{x}^2 = \frac{554}{30} - 4^2$

$$= 18.47 - 16$$

$$= 2.47$$

Therefore, $\sigma_x = \sqrt{2.47}$

Short cut method/Step deviation method/ Change of origin and scale method :

Let $u = \frac{X - A}{h}$

Then $Var(u) = \sigma_u^2 = \frac{\sum_{i=1}^n u_i^2}{n} - (\bar{u})^2$

And $Var(X) = h^2 \cdot Var(u)$

i.e. $\sigma_x^2 = h^2 \cdot \sigma_u^2$

S.D. is $\sigma_x = h \cdot \sigma_u$

Ex. 4. Compute variance and standard deviation for the following data:

x	15	20	25	30	35	40	45
f	13	12	15	18	17	10	15

Solution:

Let $u = \frac{x-30}{5}$

x	u	f	f.u	f.u ²
15	-3	13	-39	117
20	-2	12	-24	48
25	-1	15	-15	15
30	0	18	0	0
35	1	17	17	17
40	2	10	20	40
45	3	15	45	135
Total		100	4	372

Table 2.6

We get, $\bar{u} = \frac{\sum_{i=1}^n f.u}{N} = \frac{4}{100} = 0.04$

Now, $\sigma_u^2 = \frac{\sum_{i=1}^n f.u^2}{N} - (\bar{u})^2$

$$= \frac{372}{100} - (0.04)^2$$

$$= 3.72 - 0.0016$$

$$= 3.7184$$

Therefore, $\sigma_x = 5 \times \sqrt{3.7184}$

Ex.5. Compute variance and standard deviation for the following data.

x	45-55	55-65	65-75	75-85	85-95	95-105	105-115	115-125
f	7	20	27	23	13	6	3	1

Solution :

Let us use short cut method to find the solution.

Let $u = \frac{X-90}{10}$. Here, A = 90 and h = 10

Calculation of variance of u :

Class	Mid value (x_i)	f_i	u_i	$f_i u_i$	$f_i u_i^2$
45-55	50	7	-4	-28	112
55-65	60	20	-3	-60	180
65-75	70	27	-2	-54	108
75-85	80	23	-1	-23	23
85-95	90	13	0	0	0
95-105	100	6	1	6	6
105-115	110	3	2	6	12
115-125	120	1	3	3	9
Total		100	-	-150	450

Table 2.7

$$\text{Now, } \bar{u} = \frac{\sum f_i u_i}{N} = \frac{-150}{100} = -1.5$$

$$\begin{aligned} \text{Var}(u) &= \sigma_u^2 = \frac{\sum f_i u_i^2}{N} - \bar{u}^2 \\ &= \frac{450}{100} - (-1.5)^2 = 4.5 - 2.25 \\ &= 2.25 \end{aligned}$$

Thus, $\text{Var}(u) = 2.25$

$$\therefore \text{Var}(X) = h^2 \cdot \text{Var}(u) = 10^2 \times 2.25 = 225$$

$$\therefore \text{S.D.} = \sigma_x = \sqrt{\text{Var}(X)} = \sqrt{225} = 15$$

Ex.6. Find the standard deviation of the following frequency distribution which gives distribution of heights of 500 plants in centimeters.

$$(\sqrt{6956} = 83.4)$$

Height of plants (in cm)	20-25	25-30	30-35	35-40	40-45	45-50
No. of plants	145	125	90	40	45	55

Solution : Let $u = \frac{X-32.5}{5}$. Here A = 32.5 and h = 5

Calculation of variance of u :

Class	Mid value (x_i)	f_i	u_i	$f_i u_i$	$f_i u_i^2$
20-25	22.5	145	-2	-290	580
25-30	27.5	125	-1	-125	125
30-35	32.5	90	0	0	0
35-40	37.5	40	1	40	40
40-45	42.5	45	2	90	180
45-50	47.5	55	3	165	495
Total		500		-120	1420

Table 2.8

$$N = \sum f = 500$$

$$\text{Now, } \bar{u} = \frac{\sum f_i u_i}{N} = \frac{-120}{500} = -0.24$$

$$\begin{aligned} \text{Var}(u) &= \sigma_u^2 = \frac{\sum f_i u_i^2}{N} - (\bar{u})^2 \\ &= \frac{1420}{500} - (-0.24)^2 \\ &= 2.84 - 0.0576 = 2.7824 \end{aligned}$$

Thus, $\text{Var}(u) = 2.7824$

$$\text{Therefore, } \text{Var}(X) = h^2 \cdot \text{Var}(u) = 5^2 \times 2.7824 = 69.56 \text{ cm}^2$$

$$\therefore \text{S.D.} = \sigma_x = \sqrt{\text{Var}(X)} = \sqrt{69.56} = 8.34$$

EXERCISE 2.2

Find the variance and S.D. for the following sets of numbers.

- 7, 11, 2, 4, 9, 6, 3, 7, 11, 2, 5, 8, 3, 6, 8, 8, 2, 6
- 65, 77, 81, 98, 100, 80, 129

3. Compute variance and standard deviation for the following data:

x	2	4	6	8	10
f	5	4	3	2	1

4. Compute the variance and S.D.

x	1	3	5	7	9
Frequency	5	10	20	10	5

5. Following data gives age of 100 students in a school. Calculate variance and S.D.

Age (In years)	10	11	12	13	14
No. of Students	10	20	40	20	10

6. The mean and variance of 5 observations are 3 and 2 respectively. If three of the five observations are 1, 3 and 5, find the values of other two observations.
7. Obtain standard deviation for the following data :

Height (in inches)	60-62	62-64	64-66	66-68	68-70
Number of students	4	30	45	15	6

8. The following distribution was obtained by change of origin and scale of variable X.

d_i	-4	-3	-2	-1	0	1	2	3	4
f_i	4	8	14	18	20	14	10	6	6

If it is given that mean and variance are 59.5 and 413 respectively, determine actual class intervals.



Let's Learn

2.5.3 Standard Deviation for Combined data :

If σ_1, σ_2 are standard deviations and \bar{x}_1, \bar{x}_2 are the arithmetic means of two data sets of sizes n_1 and n_2 respectively, then the mean for the combined data is :

$$\bar{x}_c = \frac{n_1 \bar{x}_1 + n_2 \bar{x}_2}{n_1 + n_2}$$

And the Standard Deviation for the combined series is :

$$\sigma_c = \sqrt{\frac{n_1(\sigma_1^2 + d_1^2) + n_2(\sigma_2^2 + d_2^2)}{n_1 + n_2}}$$

Where, $d_1 = \bar{x}_1 - \bar{x}_c$ and $d_2 = \bar{x}_2 - \bar{x}_c$

SOLVED EXAMPLES

Ex.1. The means of two samples of sizes 10 and 20 are 24 and 45 respectively and the standard deviations are 6 and 11. Obtain the standard deviation of the sample of size 30 obtained by combining the two samples. ($\sqrt{19067} = 138$)

Solution :

Let $n_1 = 10, n_2 = 20, \bar{x}_1 = 24, \bar{x}_2 = 45, \sigma_1 = 6, \sigma_2 = 11$

Combined mean is :

$$\begin{aligned} \bar{x}_c &= \frac{n_1 \bar{x}_1 + n_2 \bar{x}_2}{n_1 + n_2} = \frac{10 \times 24 + 20 \times 45}{10 + 20} \\ &= \frac{1140}{30} = 38 \end{aligned}$$

Combined standard deviation is given by,

$$\sigma_c = \sqrt{\frac{n_1(\sigma_1^2 + d_1^2) + n_2(\sigma_2^2 + d_2^2)}{n_1 + n_2}}$$

Where, $d_1 = \bar{x}_1 - \bar{x}_c$ and $d_2 = \bar{x}_2 - \bar{x}_c$

$\therefore d_1 = \bar{x}_1 - \bar{x}_c = 24 - 38 = -14$ and $d_2 = \bar{x}_2 - \bar{x}_c = 45 - 38 = 7$

$$\begin{aligned} \sigma_c &= \sqrt{\frac{10(6^2 + (-14)^2) + 20(11^2 + 7^2)}{10 + 20}} \\ &= \sqrt{\frac{2320 + 3400}{30}} = \sqrt{\frac{5720}{30}} \\ &= \sqrt{190.67} = 13.8 \end{aligned}$$

Ex.2. The first group has 100 items with mean 45 and variance 49. If the combined group has 250 items with mean 51 and variance 130, find the mean and standard deviation of second group.

Solution :

Given, $n_1 = 100, \bar{x}_1 = 45, \sigma_1^2 = 49$

For combined group, $n = 250, \bar{x}_c = 51,$

$$\sigma_c^2 = 130,$$

To find : \bar{x}_2 and σ_2

$$n = n_1 + n_2 \rightarrow 250 = 100 + n_2 \rightarrow n_2 = 150$$

$$\text{We have, } \bar{x}_c = \frac{n_1 \bar{x}_1 + n_2 \bar{x}_2}{n_1 + n_2}$$

$$51 = \frac{100 \times 45 + n_2 \bar{x}_2}{100 + 150}$$

$$12750 = 4500 + 150 \cdot \bar{x}_2$$

$$\text{Therefore, } \bar{x}_2 = 55$$

Combined standard deviation is given by,

$$\sigma_c^2 = \frac{n_1(\sigma_1^2 + d_1^2) + n_2(\sigma_2^2 + d_2^2)}{n_1 + n_2}$$

$$\text{Where, } d_1 = \bar{x}_1 - \bar{x}_c = 45 - 51 = -6$$

$$\text{and } d_2 = \bar{x}_2 - \bar{x}_c = 55 - 51 = 4$$

$$130 = \frac{100(49 + 36) + 150(\sigma_2^2 + 16)}{100 + 150}$$

$$32500 = 150\sigma_2^2 + 10900$$

$$\sigma_2^2 = 144$$

$$\text{Therefore, } \sigma_2 = \sqrt{144} = 12$$

$$\therefore \text{S.D. of second group} = 12$$



Let's Learn

2.6 Coefficient of Variation :

Standard deviation depends on the unit of measurements. It is therefore not useful for comparing series of data measured in different units **Coefficient of Variation (C.V.)** is independent of the unit of measurement, and it is defined by,

$$\text{C. V.} = 100 \times \frac{\sigma}{x}$$

Coefficient of Variation is used to compare the variability of two distributions. A distribution

with smaller C.V. is said to be more homogenous or compact, more consistent or steadier and a distribution with larger C.V. is said to be more heterogeneous or more variable.

SOLVED EXAMPLES

Ex.1. The arithmetic mean of runs scored by 3 batsmen Varad, Viraj and Akhilesh in the same series are 50, 58 and 21 respectively. The standard deviation of their runs are 11, 16 and 5 respectively. Who is the most consistent of the three? If one of the three is to be selected, who will be selected?

Solution :

Let $\bar{x}_1, \bar{x}_2, \bar{x}_3$ and $\sigma_1, \sigma_2, \sigma_3$ be the means and standard deviations of the three batsmen Varad, Viraj and Akhilesh respectively.

Therefore, $\bar{x}_1 = 50, \bar{x}_2 = 58, \bar{x}_3 = 21$ and $\sigma_1 = 11, \sigma_2 = 16, \sigma_3 = 5$

Now,

$$\text{C. V. of runs scored by Varad} = 100 \times \frac{\sigma_1}{x_1} = 100 \times \frac{11}{50} = 22\%$$

$$\text{C. V. of runs scored by Viraj} = 100 \times \frac{\sigma_2}{x_2} = 100 \times \frac{16}{58} = 27.59\%$$

$$\text{C. V. of runs scored by Akhilesh} = 100 \times \frac{\sigma_3}{x_3} = 100 \times \frac{5}{21} = 23.81\%$$

- (i) Since the C. V. of the runs is smaller for Varad, he is the most consistent player.
- (ii) To take decision regarding the selection, let us consider both the C.V.s and means.

(a) Based on consistency :

Since C.V. of Varad is smallest, he is more consistent and hence is to be selected.

(b) Based on expected score :

If the player with highest expected score is to be selected, then Viraj will be selected.

Ex.2. The following values are calculated in respect of prices of shares of companies X and Y. State the share of which company is more stable in value.

	Share of X	Share of Y
Mean	50	105
Variance	7	4

Solution :

Here, $\sigma_x^2 = 7$, $\sigma_y^2 = 4$, $\bar{x} = 50$, $\bar{y} = 105$

Therefore $\sigma_x = \sqrt{7} = 2.64$, $\sigma_y = 2$,

$$\text{C.V.}(X) = 100 \times \frac{\sigma_x}{\bar{x}} = 100 \times \frac{2.64}{50} = 5.28\%$$

$$\text{C.V.}(Y) = 100 \times \frac{\sigma_y}{\bar{y}} = 100 \times \frac{2}{105} = 1.90\%$$

Since $\text{C.V.}(Y) < \text{C.V.}(X)$,

The shares of company Y are more stable in value.

Let's Construct...

Construct the table showing the frequencies of words with different number of letters occurring in the following passage, omitting punctuation marks. Take the number of letters in each word as one variable and obtain the mean, S.D. and the coefficient of variation of its distribution.

“Take up one idea. Make that one idea your life – think of it, dream of it, live on that idea. Let the brain, muscles, nerves, every part of your body, be full of that idea, and just leave every other idea alone. This is way to success.”

EXERCISE 2.3

1. Mean and standard deviation of two distributions of 100 and 150 items are 50, 5 and 40, 6 respectively. Find the mean and standard deviations of all the 250 items taken together.

2. For a certain bivariate data, following information is available.

	X	Y
Mean	13	17
S. D.	3	2
Size	10	10

Obtain the combined standard deviation.

3. Calculate coefficient of variation of marks secured by a student in the exam, where the marks are: 2, 4, 6, 8, 10.

(Given : $\sqrt{3.6} = 1.8974$)

4. Find the coefficient of variation of a sample which has mean equal to 25 and standard deviation of 5.

5. A group of 65 students of class XI have their average height is 150.4 cm with coefficient of variation 2.5%. What is the standard deviation of their height?

6. Two workers on the same job show the following results:

	Worker P	Worker Q
Mean time for completing the job (hours)	33	21
Standard Deviation (hours)	9	7

(i) Regarding the time required to complete the job, which worker is more consistent?

(ii) Which worker seems to be faster in completing the job?

7. A company has two departments with 42 and 60 employees respectively. Their average weekly wages are Rs. 750 and Rs. 400. The standard deviations are 8 and 10 respectively.

(i) Which department has a larger bill?

(ii) Which department has larger variability in wages?

8. The following table gives weights of the students of class A. Calculate the coefficient of variation (Given : $\sqrt{0.8} = 0.8944$)

Weight (in kg)	Class A
25-35	8
35-45	4
45-55	8

9. Compute coefficient of variation for team A and team B. (Given : $\sqrt{26} = 5.099$, $\sqrt{22} = 4.6904$)

No. of goals	0	1	2	3	4
No. of matches played by team A	18	7	5	16	14
No. of matches played by team B	14	16	5	18	17

Which team is more consistent?

10. Given below is the information about marks obtained in Mathematics and Statistics by 100 students in a class. Which subject shows the highest variability in marks?

	Mathematics	Statistics
Mean	20	25
S.D.	2	3



Let's Remember

- **Range = Largest Value – Smallest Value = L – S**
- **Inter quartile range = $Q_3 - Q_1$**
- **Quartile deviation = $\frac{Q_3 - Q_1}{2}$**
- **Variance and Standard Deviation for raw data :**

Let the variable X takes the values $x_1, x_2, x_3, \dots, x_n$.

Let \bar{x} be the arithmetic mean. Then,

$$\begin{aligned} \text{Var}(X) &= \sigma^2 = \frac{1}{n} \sum_{i=1}^n (x_i - \bar{x})^2 \\ &= \frac{\sum_{i=1}^n x_i^2}{n} - (\bar{x})^2 \end{aligned}$$

$$\text{Where } \bar{x} = \frac{\sum x_i}{n}$$

$$\text{And S. D.} = \sigma_x = \sqrt{\text{Var}(X)}$$

- **Variance and Standard Deviation for frequency distribution :**

$$\begin{aligned} \text{Var}(X) = \sigma^2 &= \frac{1}{n} \sum_{i=1}^n f_i (x_i - \bar{x})^2 \\ &= \frac{\sum_{i=1}^n f_i x_i^2}{n} - (\bar{x})^2 \end{aligned}$$

$$\text{Where, } \bar{x} = \frac{\sum f_i x_i}{N}$$

$$\text{and } \sum f_i = N = \text{Total frequency}$$

$$\text{S. D.} = \sigma = \sqrt{\text{Var}(X)}$$

- **Step - deviation Method : (Change of origin & scale method)**

$$\text{Let } u = \frac{X - A}{h},$$

Where A is assumed mean and h is width of the class (common multiple)

$$\text{Then } \text{Var}(u) = \sigma_u^2 = \frac{\sum f_i u_i^2}{n} - (\bar{u})^2$$

$$\text{And } \text{Var}(X) = h^2 \cdot \text{Var}(u)$$

$$\text{i.e. } \sigma_x^2 = h^2 \sigma_u^2$$

$$\text{S.D. is } \sigma_x = h \cdot \sigma_u$$

- **Standard Deviation for Combined data :**

$$\sigma_c = \sqrt{\frac{n_1(\sigma_1^2 + d_1^2) + n_2(\sigma_2^2 + d_2^2)}{n_1 + n_2}}$$

$$\text{Where, } d_1 = \bar{x}_1 - \bar{x}_c \text{ and } d_2 = \bar{x}_2 - \bar{x}_c$$

- **Coefficient of Variation :**

$$\text{C. V.} = 100 \times \frac{\sigma}{x}$$

MISCELLANEOUS EXERCISE-2

Q. Find the range for the following data :

- 116, 124, 164, 150, 149, 114, 195, 128, 138, 203, 144
- Given below the frequency distribution of weekly wages of 400 workers. Find the range.

Weekly wages (in '00 Rs.)	10	15	20	25	30	35	40
No. of workers	45	63	102	55	74	36	25

3. Find the range of the following data

Classes	115-125	125-135	135-145	145-155	155-165	165-175
Fre- quency	1	4	6	1	3	5

4. The city traffic police issued challans for not observing the traffic rules:

Day of the Week	Mon	Tue	Wed	Thus	Fri	Sat
No. of Challans	40	24	36	58	62	80

Find Q.D.

5. Calculate Q.D. from the following data.

X (less than)	10	20	30	40	50	60	70
Frequency	5	8	15	20	30	33	35

6. Calculate the appropriate measure of dispersion for the following data.

Wages (In Rs.)	Less than 35	35-40	40-45	45-50	50-55	55-60
No. of Workers	15	50	85	40	27	33

7. Calculate Q.D. of the following data.

height of plants (in feet)	2-4	4-6	6-8	8-10	10-12	12-14	14-16
No. of plants	15	20	25	12	18	13	17

8. Find variance and S.D. for the following set of numbers.

25, 21, 23, 29, 27, 22, 28, 23, 27, 25

(Given $\sqrt{6.6} = 2.51$)

9. Following data gives no. of goals scored by a team in 100 matches.

No. of Goals Scored	0	1	2	3	4	5
No. of matches	5	20	25	15	20	5

Compute variance and standard deviation for the above data.

10. Compute arithmetic mean and S.D. and C.V. (Given $\sqrt{296} = 17.20$)

C.I.	45-55	55-65	65-75	75-85	85-95	95-105
f	4	2	5	3	6	5

- The mean and S.D. of 200 items are found to be 60 and 20 respectively. At the time of calculation two items were wrongly taken as 3 and 67 instead of 13 and 17. Find the correct mean and variance.
- The mean and S.D. of a group of 48 observation are 40 and 8 respectively. If two more observations 60 and 65 are added to set, find the mean and S.D. of 50 items.
- The mean height of 200 students is 65 inches. The mean heights of boys and girls are 70 inches and 62 inches respectively and the standard deviations are 8 and 10 respectively. Find the number of boys and the combined S.D.
- From the following data available for 5 pairs of observations of two variables x and y, obtain the combined S.D. for all 10 observations.

$$\text{Where, } \sum_{i=1}^n x_i = 30, \sum_{i=1}^n y_i = 40, \sum_{i=1}^n x_i^2 = 225,$$

$$\sum_{i=1}^n y_i^2 = 340$$

15. The mean and standard deviations of two brands of watches are given below :

	Brand-I	Brand-II
Mean	36 months	48 months
S.D.	8 months	10 months

Calculate a coefficient of variation of the two brands and interpret the results.

16. Calculate coefficient of variation for the data given below [Given : $\sqrt{3.3} = 1.8161$]

C.I.	5-15	15-25	25-35	35-45	45-55	55-65	65-75
f	6	7	15	25	8	18	21

Activity 2.1

Range :

The daily sale of sugar in a certain grocery shop is given below :

Mon-day	Tues-day	Wednes-day	Thurs-day	Fri-day	Satur-day
120kg	75kg	33kg	140.5kg	50kg.	70.5kg

Then $L = \underline{\hspace{2cm}}$, $S = \underline{\hspace{2cm}}$,

Range = $L - S = \underline{\hspace{2cm}}$ kg

Activity 2.2

Inter quartile range :

Consider the following data :

2, 4, 5, 6, 8, 10, 12, 14, 20, 30, 60

Here, $n = 11$

$Q_1 =$ Value of $\left(\frac{n+1}{4}\right)^{th}$ observation

$=$ Value of 3rd observation $= \underline{\hspace{2cm}}$

$Q_3 =$ Value of 3 $\left(\frac{n+1}{4}\right)^{th}$ observation

$=$ Value of $\underline{\hspace{1cm}}$ th observation $= \underline{\hspace{2cm}}$

\therefore Inter Quartile Range $= Q_3 - \underline{\hspace{1cm}} = \underline{\hspace{2cm}}$



Activity 2.3

Variance and Standard Deviation :

Suppose the returns on an investment for 4 years are :

Rs.1000, Rs.3000, Rs. 4500 & Rs.5000.

Then, mean $= \bar{x} = \underline{\hspace{2cm}}$

$x - \bar{x} : \underline{\hspace{1cm}}, \underline{\hspace{1cm}}, \underline{\hspace{1cm}}, \underline{\hspace{1cm}}$

$(x - \bar{x})^2 : \underline{\hspace{1cm}}, \underline{\hspace{1cm}}, \underline{\hspace{1cm}}, \underline{\hspace{1cm}}$

$\sum (x - \bar{x})^2 : \underline{\hspace{2cm}}$

$\text{Var}(X) = \frac{\sum(x - \bar{x})^2}{n}$

S.D. $= \sqrt{\square}$

Activity 2.4

Select 4 grocery items, like Rice, Wheat, Sugar and Tur-Dal, Make 4 groups of students

1st group will record price of Rice in 10 shops

2nd group will record price of Wheat in 10 shops

3rd group will record price of Sugar in 10 shops

4th group will record price of Tur-Dal in 10 shops. Every group will find mean & S.D. for each of the grocery items.

Use same activity to calculate all partition values.

3. SKEWNESS



Let's Study

- Skewness
- Measures of skewness



Let's Learn

Two distributions having similar measures of central tendency and dispersion can still be different in terms of symmetry. This is necessarily important as it gives visual sense of data in numerical terms. Also these numbers help us indicate whether a distribution has higher frequencies (associated with the observations) accumulated in the left or towards the right end of the axis; this is a measure of symmetry called Skewness.

3.1 Skewness

Skewness indicates whether a distribution is symmetric or asymmetric and if asymmetric, it also indicates the extent of asymmetry with direction.

Zero Skewness: Say for instance, there is frequency distribution such that the **values of variables equidistant from the mean have equal frequencies**. In this case, the distribution is said to be symmetric (Zero Skewness) (fig. 3.3)

X (variable)	14	16	18	20	22	24	26
f (frequency)	2	5	10	14	10	5	2

Mean from the above table is 20

Note that Values of x equidistant from mean

have equal frequencies. i.e. 18 and 22 are at a distance of 2 from 20 (mean) and have equal frequencies of 10 and 10 respectively. So on and so forth.

This is an indication of symmetric distribution.

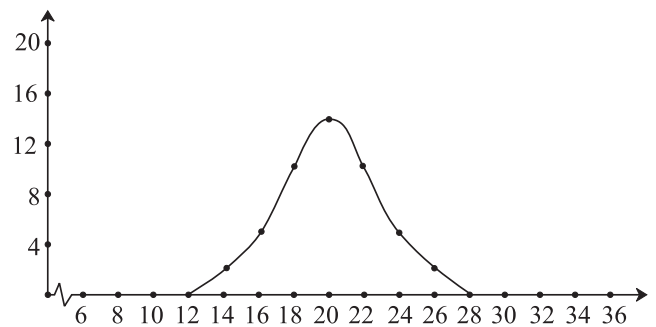

Fig 3.1

Symmetric distribution has mean = median = mode. For example length of rods, weight of individuals are usually approximately symmetric.

3.1.1 Asymmetric distribution (Positive skewness):

In cases where the values of x that are equidistant from mean have unequal frequencies, the distribution is said to be asymmetric. An asymmetric distribution is said to be positively skewed if the frequencies of the values of the variable lower than the mean have high frequencies compared to the frequencies associated with the values of variables higher than the mean.

In a visual graph, the right tail of such a distribution is longer and is called positively skewed distribution as the tail points to the positive end (higher side) of the x axis. (fig. 3.4).

It is quite logical that in such a distribution mean > Median > mode.

Salaries of employees are often positively skewed because of very few people getting high salaries. The high frequencies associated with the lower values of x are not offset by corresponding frequencies of the higher values of x .

Example and graph for positively skewed distribution:

X (variable)	14	16	18	20	22	24	26
f (frequency)	2	8	17	10	7	4	2

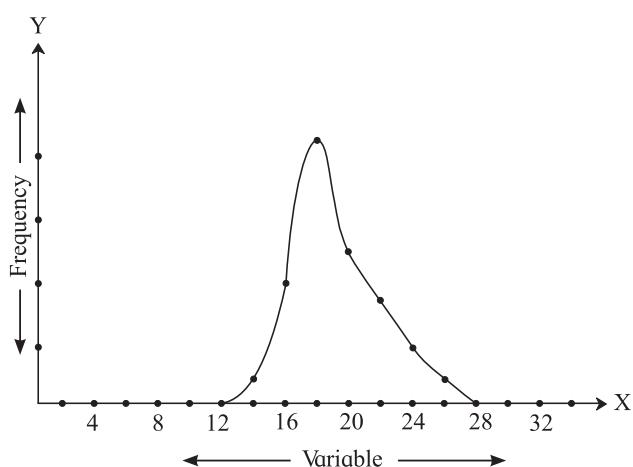

Fig 3.2

3.1.2 Asymmetric (Negative skewness):

An asymmetric distribution is said to be negatively skewed if the frequencies of the values of variables higher than mean have high frequencies compared to the frequencies associated with the variables lower than the mean.

The left tail of such a distribution is longer than the right tail (hence negatively skewed) as the tail points to the negative end of the x axis. (fig. 3.5).

In such a distribution $\text{mode} > \text{median} > \text{mean}$.

The lifespan of individuals are often negatively skewed because the frequencies associated with the higher values of x is high as compared to the frequencies associated with lower values of x .

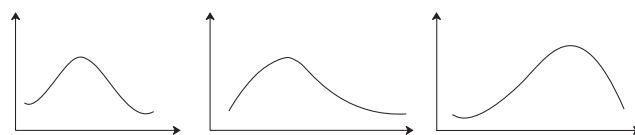

Fig 3.3

Fig 3.4

Fig 3.5

3.2 Measures of Skewness:

3.2.1 Karl Pearson's Coefficient of skewness (Pearsonian Coefficient of skewness):

The distance between mean and mode along with the sign (indicated by + or -) can be considered as the indicator of skewness. However with such a measure i.e. Mean - Mode, it is not possible to compare distributions of different nature.

For example : We cannot compare the skewness of weights of new born human babies and weights of new born lion cubs. These are two different things and hence cannot be compared.

To make comparison in such situations possible, we divide the difference of mean and mode by standard deviation. Karl Pearson suggested this method and hence it is known as Pearsonian coefficient of skewness.

$$Sk_p = \frac{\text{Mean} - \text{Mode}}{\text{S.D.}}$$

3.2.2 Features of Pearsonian coefficient:

Sk_p is free from the units of the data values and also free from the size of values. Hence, comparison is possible across various distributions of different size.

For symmetric distribution, $Sk_p = 0$

For Positively skewed distribution $Sk_p > 0$

For negatively skewed distribution $Sk_p < 0$

Most Sk_p values lie between -1 and 1 ; all Sk_p values lie between -3 and 3.

In cases where mode is indeterminate we may use the following:

$$\text{Mean} - \text{Mode} = 3(\text{mean} - \text{median});$$

Sk_p can be defined as:

$$Sk_p = 3 \left(\frac{\text{Mean} - \text{Median}}{\text{S.D.}} \right)$$

SOLVED EXAMPLES

Ex.1 Following is the data for distribution of profits (in lakhs of rupees) of firms. Find Sk_p.

Profit	10-20	20-30	30-40	40-50	50-60
No. of firms	12	18	25	10	7

(Given $\sqrt{112.96} = 10.6283$)

Solution : The class indicated by 30-40 is modal class as it has maximum frequency

f_m is the frequency of modal class = 25

f_1 is frequency of pre-modal class = 18

f_2 is the frequency of post modal class = 10

h = class-width = 10

L = modal class lower limit = 30

$$\begin{aligned} \text{Mode} &= L + \frac{(f_m - f_1) \cdot h}{2f_m - f_1 - f_2} \\ &= 30 + \frac{(25-18) \cdot (10)}{(2)(25) - 18 - 10} \\ &= 30 + \frac{70}{22} = 33.18 \end{aligned}$$

Class	Fre- quency (f_i)	Class Mark (x_i)	$u_i = (x_i - 35)/10$	$f_i u_i$	$f_i u_i^2$
10-20	12	15	-2	-24	48
20-30	18	25	-1	-18	18
30-40	25	35	0	0	0
40-50	10	45	1	10	10
50-60	7	55	2	7	14
Total	N=72			-25	90

Table 3.1

$$\bar{u} = \frac{\sum f_i u_i}{N} = \frac{-25}{72} = -0.347$$

$$\bar{x} = 35 + 10 \bar{u} = 35 - 3.47 = 31.53$$

$$\sigma_u^2 = \frac{\sum f_i u_i^2}{N} - (\bar{u})^2 = \frac{90}{72} - (-0.347)^2$$

$$= 1.25 - 0.1204 = 1.1296$$

$$\sigma_x^2 = (10^2) \sigma_u^2 = (100)(1.1296) = 112.96$$

$$\sigma_x = \sqrt{112.96}$$

$$= 10.6283$$

$$Sk_p = \frac{(\text{Mean} - \text{Mode})}{\text{S.D.}}$$

$$= \frac{31.53 - 33.18}{10.6283}$$

$$= \frac{-1.65}{10.6283}$$

= -0.1552; Sk_p < 0, implies negative skewness

3.2.3 Bowley's coefficient of skewness:

Prof. Bowley developed this relative measure of skewness. The formula for which is given by:

$$\begin{aligned} Sk_b &= \frac{(Q_3 - Q_2) - (Q_2 - Q_1)}{(Q_3 - Q_2) + (Q_2 - Q_1)} \\ &= \frac{Q_3 + Q_1 - 2Q_2}{Q_3 - Q_1} \end{aligned}$$

Let's decipher this further; For a symmetric distribution, the value that Sk_b will assume is 0 as Q₁, Q₂ and Q₃ are equidistant (because Q₃ - Q₂ = Q₂ - Q₁ for this case).

For a positive skewed distribution Q₁ is nearer to Q₂ as compared to Q₃ because the values are accumulated towards the lower part (left hand side) of the distribution.

Hence it follows that (Q₃ - Q₂) > (Q₂ - Q₁). This implies that the numerator is positive and

as the denominator is inherently positive, SK_b is positive. Conversely, for a negatively skewed distribution, Q_3 is nearer to Q_2 than Q_1 , hence $Q_3 - Q_2 < Q_2 - Q_1$, therefore the value of SK_b is negative (because the numerator assumes negative value).

The relative positioning of Q_1 , Q_2 and Q_3 is as shown in the figure below for positive and negative skewed distribution:

Positive skew:

$$(Q_3 - Q_2) > (Q_2 - Q_1)$$

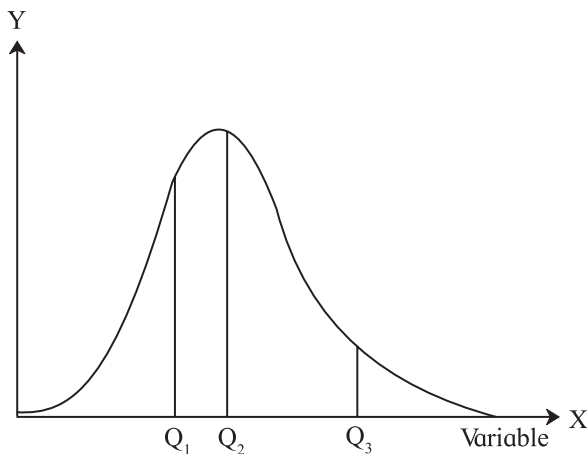

Fig 3.6 Positively Skewed Distribution

Negative Skew:

$$(Q_3 - Q_2) < (Q_2 - Q_1)$$

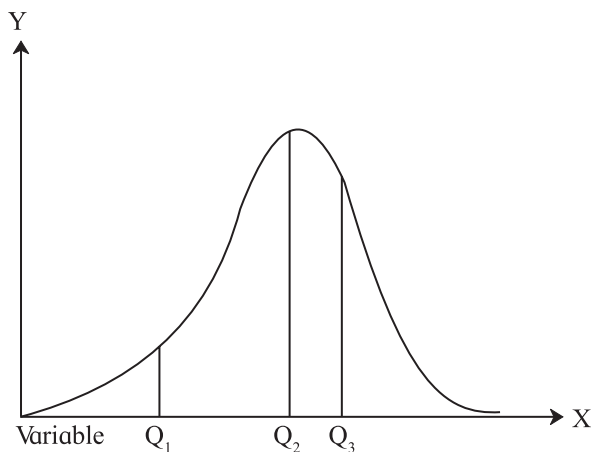

Fig 3.7 Negatively Skewed Distribution

Remarks:

- 1) $SK_b > 0$ is an indicator of positively skewed distribution.

Similarly, $SK_b < 0$ is an indicator of negatively skewed distribution.

$SK_b = 0$ indicated symmetric distribution.

- 2) SK_b lies between -1 and 1.
- 3) SK_b can be computed for distributions with open ended classes at extremity as well. As these open ended classes do not impact quartiles on which the SK_b is based. To clarify this let's look at the following example.

SOLVED EXAMPLES

Ex.1 If $Q_1 = 80$, $Q_2 = 100$, $Q_3 = 120$, find Bowley's coefficient of skewness.

Solution :

$$\begin{aligned} SK_b &= \frac{Q_3 + Q_1 - 2Q_2}{Q_3 - Q_1} \\ &= \frac{120 + 80 - 2(100)}{120 - 80} = \frac{200 - 200}{40} = \frac{0}{40} \\ &= 0 \end{aligned}$$

The Bowley's coefficient of skewness is 0, hence the data is symmetric.

Ex.2 Calculate Bowley's coefficient of skewness for the following distribution of weekly wages of workers.

Wages	Below 300	300-400	400-500	500-600	600-700	Above 700
No. of Workers	5	8	18	35	27	7

Class	Frequency	Less Than Type cumulative frequency
Below 300	5	5
300-400	8	13
400-500	18	31
500-600	35	66
600-700	27	93
Above 700	7	100
Total	N=100	

Table 3.2

$$Q_1 = \text{value of } \left(\frac{N}{4}\right)^{\text{th}} \text{ observation.}$$

= value of 25th observation.

25th observation belongs to the class 400-500.

Its frequency (f) is equal to 18 and cumulative frequency of the previous class is equal to 13.

$$\begin{aligned} Q_1 &= L + \frac{h.(N/4 - C.F.)}{f} \\ &= 400 + \frac{(100)(25 - 13)}{18} \\ &= 466.67 \end{aligned}$$

$$Q_2 = \text{value of } \left(\frac{N}{2}\right)^{\text{th}} \text{ observation}$$

= value of 50th observation.

50th observation is from class 500 – 600

f=35 and C.F. = 31

$$\begin{aligned} Q_2 &= L + \frac{h.(N/2 - C.F.)}{f} \\ &= 500 + \frac{(100)(50 - 31)}{35} \\ &= 554.28 \end{aligned}$$

$$Q_3 = \text{value of } \left(\frac{3N}{4}\right)^{\text{th}} \text{ observations}$$

= value of 75th observation

75th observation belongs to class 600 to 700

f = 27, C.F. = 66

$$\begin{aligned} Q_3 &= L + \frac{h.(3N/4 - C.F.)}{f} \\ &= \frac{(100)(75 - 66)}{27} \\ &= 633.33 \end{aligned}$$

Bowley's coefficient of skewness is given by

$$\begin{aligned} Sk_b &= \frac{Q_3 + Q_1 - 2Q_2}{Q_3 - Q_1} \\ &= \frac{633.33 + 66.67 - 2(554.28)}{633.33 - 466.67} \\ &= \frac{1100 - 1108.56}{166.66} \\ &= -0.05 \end{aligned}$$

Ex.3 For a skewed distribution

Mean = 100, median = 98.5 and SD = 9. Find the mode and the Pearsonian coefficient of skewness (Sk_p) of the distribution.

Mean – mode = 3(mean – median)

100 – mode = 3(100 – 98.5)

Mode = 100 – 4.5

= 95.5

$$\begin{aligned} Sk_p &= \frac{(\text{Mean} - \text{Mode})}{\text{S.D.}} \\ &= \frac{100 - 95.5}{9} \\ &= \frac{4.5}{9} \\ &= 0.5 \end{aligned}$$

$Sk_p > 0$, the distribution is positively skewed.

Ex.4 Mode is greater than the mean by 7 and the variance is 100. Compute the coefficient of skewness. Is the data positively or negatively skewed?

Solution:

Mode – Mean = 7

Mean – mode = –7

Variance = 100 ---- as given.

S.D. = 10

$$SK_p = \frac{(\text{Mean} - \text{Mode})}{\text{S.D.}}$$

$$= \frac{-7}{10}$$

$$= -0.7.$$

$Sk_p < 0$, the distribution is negatively skewed.

Ex.5 If Arithmetic mean = 214

Mode = 210

Variance = 196

Karl Pearson's coefficient of skewness and nature of distribution is given by:

$$Sk_p = \frac{(\text{Mean}-\text{Mode})}{\text{S.D.}}$$

$$= \frac{214-210}{\sqrt{196}}$$

$$= \frac{-4}{14}$$

$$= -0.2857 < 0$$

\therefore The distribution is negatively skewed.

Ex.6 For a frequency distribution, the lower quartile is 35 and median is 40. If the distribution is symmetric, find the upper quartile.

Lower quartile = $Q_1 = 35$

Median = 40

$Sk_b = 0$ -----the distribution is symmetric.

$$Sk_b = \frac{Q_3 + Q_1 - 2Q_2}{Q_3 - Q_1}$$

$$0 = \frac{Q_3 + Q_1 - 2Q_2}{Q_3 - Q_1}$$

$$Q_3 = 2Q_2 - Q_1$$

$$= 2(40) - 35$$

$$= 80 - 35$$

$$= 45$$

The upper quartile $Q_3 = 45$.

5) $Q_1 = 15$

$Q_2 = 21$

$Q_3 = 29$

Calculate Bowley's coefficient of skewness

$$Sk_b = \frac{29+15-42}{29-15}$$

$$= \frac{2}{14}$$

$= 0.143 > 0$, Hence the

the distribution is positively skewed

ADDITIONAL SOLVED EXAMPLES

Ex.1 Obtain the relation between Mean and Mode so that Distribution is negatively skewed.

Solution : Since we want relation between Mean and Mode therefore we use the formula of Karl Person's coefficient of skewness.

$$Sk_p = \frac{\text{Mean} - \text{Mode}}{\text{S.D.}}$$

$$\therefore (Sk_p)(\text{S.D.}) = \text{Mean} - \text{Mode}$$

S.D. is always positive and distribution is negatively skew.

$$\therefore \text{Mean} - \text{Mode} < 0$$

$$\therefore \text{Mean} < \text{Mode}$$

Which is the required relation.

Ex.2 Obtain the relation between upper quartile, lower quartile and median quartile so that Distribution is symmetric.

Solution : We want the relation between quartile so we use Bowley's coefficient of skewness

$$Sk_b = \frac{(Q_3 - Q_2) - (Q_2 - Q_1)}{(Q_3 - Q_2) + (Q_2 - Q_1)}$$

Since distribution is symmetric $\therefore Sk_b = 0$

$$\therefore Q_3 - Q_2 = Q_2 - Q_1$$

$$2Q_2 = Q_1 + Q_3$$

∴ Q_1, Q_2, Q_3 are in A.P.

Ex.3 Q_1, Q_2, Q_3 are in A.P. then discuss the nature of skewness

Solution : Simplest A.P. is 1, 2, 3

$$Q_1 = 1, Q_2 = 2, Q_3 = 3$$

Here we have to use Bowley's coefficient of skewness

$$\begin{aligned} Sk_b &= \frac{(Q_3 - Q_2) - (Q_2 - Q_1)}{(Q_3 - Q_2) + (Q_2 - Q_1)} \\ &= \frac{(3 - 2) - (2 - 1)}{(3 - 2) + (2 - 1)} \\ &= \frac{1 - 1}{1 + 1} = \frac{0}{2} \\ &= 0 \end{aligned}$$

∴ The Distribution is symmetric.

Ex.4 Discuss the nature of distribution of Mean > Mode.

Solution : Here we use Karl Pearson's coefficient of skewness because we have relation between mean and mode

$$Sk_p = \frac{\text{Mean} - \text{Mode}}{\text{S.D.}}$$

As S.D. is always positive sign of Sk_p depends on sign of Mean-Mode. We have Mean > Mode

$$\therefore \text{Mean} - \text{Mode} > 0$$

$$\therefore Sk_p > 0$$

∴ Distribution is positively skewed.

EXERCISE 3.1

- 1) For a distribution, mean = 100 mode = 127 and SD = 60. Find the Pearson coefficient of skewness Sk_p .
- 2) The mean and variance of the distribution is 60 and 100 respectively. Find the mode and the median of the distribution if $Sk_p = -0.3$

- 3) For a data set, sum of upper and lower quartiles is 100, difference between upper and lower quartiles is 40 and median is 30. Find the coefficient of skewness.
- 4) For a data set with upper quartile equal to 55 and median equal to 42. If the distribution is symmetric, find the value of lower quartile.
- 5) Obtain coefficient of skewness by formula and comment on nature of the distribution.

Height in inches	No. of Females
Less than 60	10
60-64	20
64-68	40
68-72	10
72-76	2

- 6) Find Sk_p for the following set of observations.
17, 17, 21, 14, 15, 20, 19, 16, 13, 17, 18
- 7) Calculate Sk_b for the following set of observations of yield of wheat in kg from 13 plots:
4.6, 3.5, 4.8, 5.1, 4.7, 5.5, 4.7, 3.6, 3.5, 4.2, 3.5, 3.6, 5.2
- 8) For a frequency distribution $Q_3 - Q_2 = 90$
And $Q_2 - Q_1 = 120$

Find Sk_b



Let's Remember

Karl Pearson's Coefficient of skewness (Pearsonian Coefficient of skewness)

$$Sk_p = \frac{\text{Mean} - \text{Mode}}{\text{S.D.}}$$

If mode is intermediate then

$$\text{Mean} - \text{Mode} = 3 \left(\frac{\text{Mean} - \text{Median}}{\text{S.D.}} \right)$$

$$\therefore Sk_p = 3 \left(\frac{\text{Mean} - \text{Median}}{\text{S.D.}} \right)$$

- Features of Pearsonian Coefficient :
 - (1) For Symmetric distribution $Sk_p = 0$
 - (2) For Positively skewed distribution $Sk_p > 0$
 - (3) For Negatively skewed distribution $Sk_p < 0$
 - (4) Most Sk_p values lie between - 1 and 1
All Sk_p values lie between - 3 and 3

- Bowley's coefficient of skewness :

$$Sk_b = \frac{Q_3 + Q_1 - 2Q_2}{Q_3 - Q_1}$$

- Features of Bowley's coefficient :
 - (1) If $Sk_b > 0$ then the distribution is positively skewed.
 - (2) If $Sk_b < 0$ then the distribution is negatively skewed.
 - (3) If $Sk_b = 0$ then the distribution is symmetric.
 - (4) $-1 < Sk_b < 1$.

Karl Pearsonian's coefficient of skewness is 0.3. Find the mode and median of the distribution.

1. Calculate Karl Pearsonian's coefficient of skewness Sk_p from the following data :

Marks above	0	10	20	30	40	50	60	70	80
No of students	120	115	108	98	85	60	18	5	0

2. Calculate Bowley's coefficient of skewness Sk_b from the following data :

Marks above	0	10	20	30	40	50	60	70	80
No of students	120	115	108	98	85	60	18	5	0

3. Find Sk_p for the following set of observations 18,27,10,25,31,13,28.
4. Find Sk_b for the following set of observations 18,27,10,25,31,13,28.

MISCELLANEOUS EXERCISE - 3

1. For a distribution, mean = 100, mode = 80 and S.D. = 20. Find Pearsonian coefficient of skewness Sk_p .
2. For a distribution, mean = 60, median = 75 and variance = 900. Find Pearsonian coefficient of skewness Sk_p .
3. For a distribution, $Q_1 = 25$, $Q_2 = 35$ and $Q_3 = 50$. Find Bowley's coefficient of skewness Sk_b .
4. For a distribution, $Q_3 - Q_2 = 40$, $Q_2 - Q_1 = 60$. Find Bowley's coefficient of skewness Sk_b .
5. For a distribution, Bowley's coefficient of skewness is 0.6. Find the upper and lower quartiles.
6. For a frequency distribution, the mean is 200, the coefficient of variation is 8% and

Activity 3.1

Collect marks in mathematics subject of 12 students in your class and arrange data in ascending order.

Complete the following table and write your comment?

$$Q_1 = \square, Q_2 = \square, Q_3 = \square, Sk_b = \square$$

Activity 3.2

Plot the points and draw free hand curve using given data

x	10	20	30	40	50	60	70	80	90	100
f	3	9	16	14	13	10	8	5	5	2

Write your comment about skewness and write relation between mean and mode.



4. BIVARIATE FREQUENCY DISTRIBUTION AND CHI SQUARE STATISTIC



Let's Study

- Meaning of bivariate frequency distribution
- Classification and Tabulation of bivariate data
- Categorical variables
- Contingency table
- Chi square statistic



Let's Recall

- ✓ Concept of univariate data
- ✓ Classification and Tabulation of data
- ✓ Univariate frequency distribution for grouped and ungrouped data
- ✓ Basic Set Theory

Let's Observe...

4.1 Meaning of bivariate frequency distribution:

So far our study was restricted to frequency distributions of single variables. Such frequency distributions are called univariate frequency distributions. We now turn our attention to the study of two variables observed on the same population.

Heights and weights, income and expenditure of a group of individuals, marks obtained by a group of students in two different subjects etc are examples of bivariate data as they involve simultaneous study of two variables.

Frequency distribution of two variables is called a bivariate frequency distribution.

4.2 Classification and Tabulation of Bivariate data:

The given data can be summarized in the form of a two way table called the bivariate frequency table. For this, the values of each variable are grouped into various classes.

Consider the following data which gives a 15 days record of number of ice candies sold and temperature of the day recorded by a shopkeeper.

Daily temperature (Celsius)	33	18	16	34	33	18	16	33
No. of ice candies sold	250	150	250	400	500	250	150	500
Daily temperature (Celsius)	18	33	16	33	18	34	34	
No. of ice candies sold	150	500	250	400	400	500	400	

- Let us denote 'Daily temperature (in Celsius)' by X and 'Number of ice candies sold' by Y
- Thus, we have two variables X and Y.
- Observe that variable X takes values from 16 to 34 and variable Y takes values from 150 to 500.
- For a bivariate frequency distribution, we construct a table by taking values of X horizontally at the top and values of Y vertically on the left side as shown below:

X Y	16	18	33	34
150				
250				
400				
500				

Table 4.1

- Now, on the first day, the temperature was 16 (X) and Number of ice candies sold (Y) was 150. Therefore, we put a tally mark in the cell corresponding to X = 33 and Y=250

X	16	18	33	34
Y				
150				
250				
400				
500				

Table 4.2

- Proceeding in the same manner, we put tally marks for each pair of observations (x, y) for all 15 days.
- Counting the number of tally marks, total frequency of each cell is written in the brackets (), after the tally marks.

X	16	18	33	34	Total (f _y)
Y					
150	(1)	(2)			3
250	(2)	(1)	(1)		4
400		(1)	(1)	(2)	4
500			(3)	(1)	4
Total (f _x)	3	4	5	3	15

Table 4.3

- Sum of all the frequencies in every row is written in the extreme right column of that row.

These frequencies together with values of Y give marginal frequency distribution of Y.

Y	150	250	400	500	Total
Frequency	3	4	4	4	15

Table 4.4

- Sum of all the frequencies in every column is written in the bottom row of that column.
- These frequencies together with values of X give marginal frequency distribution of X.

X	16	18	33	34	Total
Frequency	3	4	5	3	15

Table 4.5

- Sum of all frequencies in extreme right columns or bottom row is written in the right bottom cell. This is the total frequency of the data.
- Applying a particular condition on X (or Y), we can obtain conditional frequency distribution of Y (or X)

Ex. (i) Conditional frequency distribution of X when Y = 250

X	16	18	33	34	Total
Frequency	2	1	1	-	4

Table 4.6

- (ii) Conditional frequency distribution of Y when X ≥ 33

X	33	34	Total (f _y)
Y			
150	-	-	-
250	(1)		1
400	(1)	(2)	3
500	(3)	(1)	4
Total (f _x)	5	3	8

Table 4.7

In general, if X and Y are two variables with m values of X and n values of Y, then the bivariate table will contain mn cells. By going through the different pairs of observations (x, y) on the two variables and using tally marks, we find frequency for each cell and obtain a bivariate frequency table as shown below.

Bivariate frequency distribution table

X Y	Values						Total frequency of Y ($f_{.j}$)	
		x_1	x_2	...	x_i	...		x_m
Values	y_1	f_{11}	f_{21}	...	f_{i1}	...	f_{m1}	$f_{.1}$
	y_2	f_{12}	f_{22}	...	f_{i2}	...	f_{m2}	$f_{.2}$

	y_j	f_{1j}	f_{2j}	...	f_{ij}	...	f_{mj}	$f_{.j}$

	y_n	f_{1n}	f_{2n}	...	f_{in}	...	f_{mn}	$f_{.n}$
Total frequency of X ($f_{i.}$)	f_1	f_2	f_m	$N = \sum_{i=1}^m f_{ij} = f_{.j}$, $\sum_{i=1}^m f_{ij} = f_{.i}$		

Table no.4.8

The i^{th} value of X is denoted by x_i and the j^{th} value of Y is denoted by y_j . Frequency associated with the pair (x_i, y_j) is denoted by f_{ij} and

Total frequency is also obtained as

$$N = \sum_{i=1}^m f_{ij} = f_{.j}, \sum_{i=1}^m f_{ij} = f_{.i}$$

4.2.1 Marginal frequency distributions:

The frequency distribution of the values of variable X together with their frequency totals ($f_{i.}$) is called marginal frequency distribution of X.

Similarly, the frequency distribution of the values of variable Y together with their frequency totals ($f_{.j}$) is called marginal frequency distribution of Y.

Marginal frequency distribution of X

X	x_1	x_2	x_m	Total
Freq.	f_1	f_2	f_m	N

Table no 4.9

Marginal frequency distribution of Y

Y	y_1	y_2	y_n	Total
Freq.	$f_{.1}$	$f_{.2}$	$f_{.n}$	N

Table no 4.10

4.2.2 Conditional frequency distributions:

Frequency distribution of one variable, when the value of the other variable is given, is called conditional frequency distribution.

Conditional frequency distribution of X when $Y=y_j$

X	x_1	x_2	...	x_i	...	x_m	Total
Freq	f_{1j}	f_{2j}	...	f_{ij}	...	f_{mj}	$f_{.j}$

Table no 4.11

Conditional frequency distribution of Y when $X=x_i$

Y	y_1	y_2	...	y_j	...	y_n	Total
Freq	f_{i1}	f_{i2}	...	f_{ij}	...	f_{in}	$f_{i.}$

Table no 4.12

SOLVED EXAMPLES

Ex.1. Following data gives age (X in years) of students in a particular school and their marks in G.K. test. Prepare a bivariate frequency distribution.

X: 11 11 10 13 12 10 12 12 13 10
11 13 12 12 12 11 13 10 10 11

Y: 22 24 23 21 24 21 22 23 24 24
22 23 21 24 21 22 24 22 23 24

Also obtain

- Marginal frequency distributions of age and marks in G.K.
- Conditional frequency distribution of age when marks in G.K. are 23
- Conditional frequency distribution of marks in G.K. when the age is 11 years.

Solution:

Write values of X horizontally and Y vertically.

X takes values from 10 to 13 and Y takes values from 21 to 24. Therefore the two way table will contain 16 cells.

The first student is 11 years old and has 22 marks in G.K.

Therefore, we put tally mark in the cell corresponding to $X=11$ and $Y=22$ etc.

Bivariate frequency distribution table of X and Y

$X \backslash Y$	10	11	12	13	f_y
21	 (1)	-	 (2)	 (1)	4
22	 (1)	 (3)	 (1)	-	5
23	 (2)	-	 (1)	 (1)	4
24	 (1)	 (2)	 (2)	 (2)	7
f_x	5	5	6	4	20

Table 4.13

(i) Marginal frequency distribution of X :

X	10	11	12	13	Total
F	5	5	6	4	20

Table 4.14

(ii) Marginal frequency distribution of Y :

Y	21	22	23	24	Total
F	4	5	4	7	20

Table 4.15

(iii) Conditional frequency distribution of X when $Y=23$

X	10	11	12	13	Total
F	2	0	1	1	4

Table 4.16

(iv) Conditional frequency distribution of Y when $X=11$

Y	21	22	23	24	Total
F	0	3	0	2	5

Table 4.17

Ex.2. Construct the frequency distribution table for the data on heights (X in cm) and weights (Y in kg) of 20 students are given below:

Height (cm)	138	139	147	144	163	142	149	140	138	139
Weight (kg)	62	56	63	54	45	46	51	43	36	58
Height (cm)	148	155	141	160	153	150	152	162	146	160
Weight (kg)	61	60	55	59	58	43	38	51	57	60

Also obtain

- Marginal frequency distributions of height (X) and weight (Y) of the students
- Conditional frequency distribution of X when Y is more than or equal to 55 kgs
- Conditional frequency distribution of Y when X lies between 135 to 145 cms

Solution: Bivariate frequency distribution table for height and weight

$X \backslash Y$	135-145	145-155	155-165	f_y
35-45	(2)	(2)	-	4
45-55	(2)	(1)	(1)	4
55-65	(4)	(4)	(4)	12
f_x	8	7	5	20

Table 4.18

(i) Marginal frequency distribution of X :

X	135-145	145-155	155-165	Total
F	8	7	5	20

Table 4.19

Marginal frequency distribution of Y :

Y	35-45	45-55	55-65	Total
F	4	4	12	20

Table 4.20

(i) Conditional frequency distribution of X when Y is more than or equal to 55 kg

X	135-145	145-155	155-165	Total
F	4	4	4	12

Table 4.21

- (ii) Conditional frequency distribution of Y when X lies in 135-145

X	35-45	45-55	55-65	Total
F	2	2	4	8

Table 4.22

EXERCISE 4.1

- 1) Following table gives income (X) and expenditure (Y) of 25 families :

X \ Y	200-300	300-400	400-500
200-300			
300-400		-	
400-500		-	-

Find

- Marginal frequency distributions of income and expenditure.
 - Conditional frequency distribution of X when Y is between 300-400.
 - Conditional frequency distribution of Y when X is between 200-300.
 - How many families have their income Rs. 300 and more and expenses Rs. 400 and less?
- 2) Two dice are thrown simultaneously 25 times. The following pairs of observations are obtained.
- (2, 3) (2, 5) (5, 5) (4, 5) (6, 4) (3, 2)
 (5, 2) (4, 1) (2, 5) (6, 1) (3, 1) (3, 3)
 (4, 3) (4, 5) (2, 5) (3, 4) (2, 5) (3, 4)
 (2, 5) (4, 3) (5, 2) (4, 5) (4, 3) (2, 3)
 (4, 1)
- Prepare a bivariate frequency distribution table for the above data. Also obtain the marginal distributions.
- 3) Following data gives the age of husbands (X) and age of wives (Y) in years. Construct

a bivariate frequency distribution table and find the marginal distributions.

X	27	25	28	26	29	27	28	26	25	25	27
Y	21	20	20	21	23	22	20	20	19	19	23
X	26	29	25	27	26	25	28	25	27	26	
Y	19	23	23	22	21	20	22	23	22	21	

Find conditional frequency distribution of age of husbands when the age of wife is 23 years.

- 4) Construct a bivariate frequency distribution table of the marks obtained by students in English(X) and Statistics(Y).

Marks in Statistics (X)	37	20	46	28	35	26	41	48	32	23	20	39	47	33	27	26
Marks in English (Y)	30	32	41	33	29	43	30	21	44	38	47	24	32	31	20	21

Construct a bivariate frequency distribution table for the above data by taking class intervals 20-30, 30-40, ... etc. for both X and Y. Also find the marginal distributions and conditional frequency distribution of Y when X lies between 30-40.

- 5) Following data gives height in cm (X) and weight in kgs (Y) of 20 boys. Prepare a bivariate frequency table taking class intervals 150-154, 155-159...etc. for X and 35-39, 40-44...etc for Y. Also find
- Marginal frequency distributions.
 - Conditional frequency distribution of Y when $155 \leq X \leq 159$

(152, 40)	(160, 54)	(163, 52)	(150, 35)
(154, 36)	(160, 49)	(166, 54)	(157, 38)
(159, 43)	(153, 48)	(152, 41)	(158, 51)
(155, 44)	(156, 47)	(156, 43)	(166, 53)
(160, 50)	(151, 39)	(153, 50)	(158, 46)

CHI SQUARE STATISTIC



Let's Learn

It is interesting to find that there is a relationship between age and type of songs people prefer to listen, gender and driving skills, day of a week and tendency of students to remain absent etc. Various types of statistical relationships

may exist among variables of interest. Each of these has some form of association between the variables.

It is common to use the 'chi-square' statistic for measuring relationship between categorical variables.

Let's Note

In general, any quantity calculated from data is called a statistic. For example, mean is a statistic.

4.3 Categorical Variables:-

A variable that takes non numerical values is called a categorical variable.

- Ex- 1) Gender - 'Male', 'Female' or 'Other'
 2) Blood group- A, B, AB, O
 3) Mother tongue of a student.

4.4 Contingency Table-

To study two categorical variables, data can be summarized in the form of a two-way frequency table. Such a bivariate frequency distribution for categorical variables is called a contingency table.

For Example – We may construct a contingency table to study the relationship between Gender and Food preference.

	Sweet	Spicy
Female	a	b
Male	c	d

Table 4.23

Where, a, b, c, d denote the frequencies.

SOLVED EXAMPLES

Ex.1 A survey was carried out to determine whether there is an association between age group and preference for ice cream flavor (Chocolate, Vanilla). Out of a sample of 180 persons, 72 were teenagers of which 40 liked chocolate flavor. 58 adults liked vanilla. Construct a two way contingency table.

Solution: The above data can be arranged in the following contingency table.

Age group	Ice-cream flavor		Total
	Chocolate	Vanilla	
Teenagers	40		72
Adults		58	
Total			180

Table 4.24

Let us complete the above table by finding missing frequencies.

Age group	Ice-cream flavor		Total
	Chocolate	Vanilla	
Teenagers	40	32	72
Adults	50	58	108
Total	90	90	180

Table 4.25

Let's Construct

A sample of 400 students was taken for survey. 140 of them were Music students. 190 of them were good in Mathematics. Prepare a 2x2 contingency table from this information.



Let's Learn

4.5 Chi-square Statistic (χ^2) :-

'Chi-square' statistic is denoted by χ^2 where, χ is a Greek letter, written as 'Chi' read like 'Kai' or 'Ki' in 'Kite'.

The χ^2 -statistic is used to measure the relationship between two categorical variables.

χ^2 is always non-negative.

Formula for computing χ^2 statistic -

$$\chi^2 = \sum \left[\frac{(O_{ij} - E_{ij})^2}{E_{ij}} \right]$$

Where,

χ^2 = Chi-square value

O_{ij} = Observed frequencies

E_{ij} = Expected frequencies

It is common to write

$$\chi^2 \text{ as } \chi^2 = \sum \left[\frac{(O - E)^2}{E} \right]$$

The **Expected frequencies** can be obtained by using the formula:

$$E_{ij} = \frac{R_i \times C_j}{N}$$

Where,

R_i = Row Total

C_j = Column Total

N = Grand Total that is Total frequency

SOLVED EXAMPLES

Ex.1: Following data is obtained from a sample of 200 people of which 80 were men and 120 were women.

	Right-handed	Left-handed
Men	40	40
Women	35	85

Table 4.26

Find the value of χ^2 statistic.

Solution:

Let us find the row and column totals and total frequency from the given 2×2 contingency table.

	Right Handed	Left Handed	Total
Men	40	40	80
Women	35	85	120
Total	75	125	200

Table 4.27

Expected frequencies are given by

$$E_{ij} = \frac{R_i \times C_j}{N}$$

Therefore,

$$E_{11} = \frac{R_1 \times C_1}{N} = \frac{80 \times 75}{200} = 30,$$

$$E_{12} = \frac{R_1 \times C_2}{N} = \frac{80 \times 125}{200} = 50$$

$$E_{21} = \frac{R_2 \times C_1}{N} = \frac{120 \times 75}{200} = 45,$$

$$E_{22} = \frac{R_2 \times C_2}{N} = \frac{120 \times 125}{200} = 75$$

Write the table of expected frequencies

We have,

$$\begin{aligned} \chi^2 &= \sum \left[\frac{(O_{ij} - E_{ij})^2}{E_{ij}} \right] \\ &= \frac{(40 - 30)^2}{30} + \frac{(40 - 50)^2}{50} + \frac{(35 - 45)^2}{45} + \frac{(85 - 75)^2}{75} \\ &= \frac{100}{30} + \frac{100}{50} + \frac{100}{45} + \frac{100}{75} \\ &= 3.33 + 2.22 + 2.00 + 1.33 \\ \chi^2 &= 8.88 \end{aligned}$$

Ex.2: A sample of boys and girls were asked to choose one colour from three options – pink, blue and orange to paint their room with the following results.

	Pink	Blue	Orange
Boys	27	63	10
Girls	41	45	14

Calculate χ^2 - statistic.

Solution:

	Pink	Blue	Orange	Total
Boys	27	63	10	100
Girls	41	45	14	100
Total	68	108	24	200

Expected frequencies are given by

$$E_{11} = \frac{100 \times 68}{200} = 34$$

$$E_{12} = \frac{100 \times 108}{200} = 54$$

$$E_{13} = \frac{100 \times 24}{200} = 12$$

$$E_{21} = \frac{100 \times 68}{200} = 34$$

$$E_{22} = \frac{100 \times 108}{200} = 54$$

$$E_{23} = \frac{100 \times 24}{200} = 12$$

Write the table of expected frequencies

Now,

$$\begin{aligned} \chi^2 &= \sum \left[\frac{(O_{ij} - E_{ij})^2}{E_{ij}} \right] \\ &= \frac{(27 - 34)^2}{34} + \frac{(63 - 54)^2}{54} + \frac{(10 - 12)^2}{12} \\ &\quad + \frac{(41 - 34)^2}{34} + \frac{(45 - 54)^2}{54} + \frac{(14 - 12)^2}{12} \\ &= 2.88 + 3 + 0.67 \\ &= 6.55 \end{aligned}$$

Activity 4.1

- 1) A group of 200 teenagers was asked to choose the type of movie they like to watch. Following results were obtained, where

the numbers in each cell give the observed frequencies while those inside the bracket () give the expected frequencies.

	Melodramatic	Action	Total
Boys	25 (45)	75 (55)	100
Girls	65 (45)	35 (55)	100
Total	90	110	200

Calculate the χ^2 - statistic.

- 2) In a Commerce college, students can choose either Mathematics or Secretarial Practice (S.P.) as an optional subject. Following information is collected from a sample of 150 students of the college.

	Mathematics	S. P.	Row Total
Boys	50	25	75
Girls	39	36	75
Column Total	89	61	N = 150

Complete the table given below:

	Mathematics		Secretarial Practice	
	Observed freq.	Expected freq.	Observed freq.	Expected freq.
Boys	50			
Girls			36	

EXERCISE 4.2

- 1) Following table shows the classification of applications for secretarial and for sales positions according to gender. Calculate the value of χ^2 statistic.

	Offered	Denied
Male	75	150
Female	25	50

- 2) 200 teenagers were asked which take out food do they prefer – French fries, burger or pizza. The results were –

	French Fries	Burger	Pizza
Boys	6	20	24
Girls	18	40	92

Compute χ^2 statistic.

- 3) A sample of men and women who had passed their driving test either in 1st attempt or in 2nd attempt were surveyed. Compute χ^2 statistic.

Passed in →	First attempt	Second attempt
Men	32	28
Women	8	12

- 4) 800 people were asked whether they wear glasses for reading with following results.

Age	Wear glasses	Do not wear glasses
≤ 30	310	90
> 30	290	110

Compute the χ^2 square statistic.

5. Out of a sample of 120 persons in a village, 80 were administered a new drug for preventing influenza and out of them 18 were attacked by influenza. Out of those who were not administered the new drug, 10 persons were not attacked by influenza:

Prepare: (a) a two-way table showing frequencies.

- (b) Compute the χ^2 square statistic.



Let's Remember

- Chi square statistic -

Formula for computing χ^2 statistic –

$$\chi^2 = \sum \left[\frac{(O_{ij} - E_{ij})^2}{E_{ij}} \right] \text{ or}$$

$$\chi^2 = \sum \left[\frac{(O - E)^2}{E} \right]$$

- Formula for Expected Frequencies -

$$E_{ij} = \frac{R_i \times C_j}{N}$$

MISCELLANEOUS EXERCISE - 4

- 1) Following data gives the coded price (x) and demand (y) of a commodity.

Price	5	7	9	8	10	7	9	8	5	11	11	10	2	3	9
De-mand	9	15	13	15	14	10	11	14	10	14	6	14	15	11	12
Price	2	4	3	14	6	10	7	15	8	6	5	6	11	14	15
De-mand	6	11	8	11	10	15	9	15	13	9	14	10	7	5	6

Classify the data by taking classes 0-4, 5-9 etc. for x and 5-8, 9-12 etc. for y

Also find

- marginal frequency distribution of x and y.
 - Conditional frequency distribution of y when x is less than 10
- 2) Following data gives the age in years and marks obtained by 30 students in an intelligence test.

Age	16	17	22	19	21	16
Marks	16	19	39	50	48	41
Age	21	20	20	23	22	19
Marks	59	44	42	62	37	67

Age	23	20	22	22	23	22
Marks	45	57	35	37	38	56
Age	17	18	16	21	19	20
Marks	54	61	47	67	49	56
Age	17	18	23	21	20	16
Marks	51	42	65	56	52	48

Prepare a bivariate frequency distribution by taking class intervals 16-18, 18-20,...etc. for age and 10-20, 20-30... etc. for marks.

Find

- (i) Marginal frequency distributions.
 - (ii) Conditional frequency distribution of marks obtained when age of students is between 20-22.
- 3) Following data gives Sales (in Lakh Rs.) and Advertisement Expenditure (in Thousand Rs.) of 20 firms
- (115, 61) (120, 60) (128, 61) (121, 63)
 (137, 62) (139, 62) (143, 63) (117, 65)
 (126, 64) (141, 65) (140, 65) (153, 64)
 (129, 67) (130, 66) (150, 67) (148, 66)
 (130, 69) (138, 68) (155, 69) (172, 68)
- i) Construct a bivariate frequency distribution table for the above data by taking classes 115-125, 125-135, ...etc. for sales and 60-62, 62-64, ...etc. for advertisement expenditure.
 - ii) Find marginal frequency distributions
 - iii) Conditional frequency distribution of Sales when the advertisement expenditure is between 64-66 (Thousand Rs.)
 - iv) Conditional frequency distribution of advertisement expenditure when the sales are between 125-135 (lakh Rs.)
- 4) Prepare a bivariate frequency distribution for the following data, taking class intervals for X as 35-45, 45-55...etc and for Y as 115-130, 130-145...etc. where, X denotes the age in years and Y denotes blood pressure for a group of 24 persons.

- (55, 151) (36, 140) (72, 160) (38, 124)
 (65, 148) (46, 130) (58, 152) (50, 149)
 (38, 115) (42, 145) (41, 163) (47, 161)
 (69, 159) (60, 161) (58, 131) (57, 136)
 (43, 141) (52, 164) (59, 161) (44, 128)
 (35, 118) (62, 142) (67, 157) (70, 162)

Also find

- (i) Marginal frequency distribution of X
 - (ii) Conditional frequency distribution of Y when $X \leq 45$
- 5) Thirty pairs of values of two variables X and Y are given below. Form a bivariate frequency table. Also find marginal frequency distributions of X and Y.

X	110	88	91	115	97	85	85	91	120	95
Y	500	800	870	599	625	650	905	700	850	824
X	82	105	99	90	108	124	90	90	111	89
Y	970	609	990	735	600	735	729	840	999	780
X	112	100	87	92	91	82	96	120	121	122
Y	638	850	630	720	695	923	555	810	805	526

- 6) Following table shows how the samples of Mathematics and Economics scores of 25 students are distributed :

Marks in Economics	Marks in Mathematics	
	40-70	70-100
40-70	20	15
70-100	5	10

Find the value of χ^2 statistic.

- 7) Compute χ^2 statistic from following data:

	Graduates	Post-Graduates
Male	28	22
Female	32	18

- 8) Attitude of 250 employees towards a proposed policy of the company is as

observed in the following table. Calculate χ^2 statistics.

	Favor	Indiffer-ent	Oppose
Male	68	46	36
Female	27	49	24

- 9) In a certain sample of 1000 families, 450 families are consumers of tea. Out of 600 Hindu families, 286 families consume tea. Calculate χ^2 statistic.
- 10) A sample of boys and girls were asked to choose their favourite sport, with the following results. Find the value of χ^2 statistics.

	Foot-ball	Crick-et	Hock-ey	Bas-ketball
Boys	86	60	44	10
Girls	40	30	25	5

Activity 4.2

Measure weight and height of at least 20 students in your class/collage and prepare a bivariate frequency table.

Activity 4.3

Complete the bivariate frequency distribution in the following table for the given data on heights (X cm) and weights (Y kg) of 20 students.

- (150, 65) (169, 71) (136, 68) (130, 66)
 (137, 65) (147, 70) (125, 64) (118, 62)
 (129, 66) (142, 70) (128, 63) (160, 70)
 (140, 65) (123, 64) (138, 67) (171, 67)
 (131, 67) (121, 65) (150, 68) (130, 66)

Weight in kg (Y)	Height in cm (X)						f_y
	115-125	125-135	135-145	145-155	155-165	165-175	
62-64							
64-66							
66-68							7
68-70							
70-72							
f_x				6			20



5. CORRELATION



Let's Study

- Concept of Correlation
- Methods of computing correlation
- Properties of Covariance
- Karl Pearson's coefficient of correlation
- Scatter diagram
- Interpretation



Let's Observe...

So far, we have studied the statistical methods used for analysis of data involving only one variable. There are situations where two variables are involved

For example consider following data,

- (i) Demand and Price of a certain commodity over a specified period of time.
- (ii) Weight of a person and Blood Pressure of the person.
- (iii) Quantity of water and crop yield.
- (iv) Sales of cosmetics and advertisements
- (v) Monthly income and expenditure of a family.

A set of observations made on two variables is called Bivariate Data. The two variables are denoted by X and Y respectively. Then observations on two variables X and Y can be represented by n ordered pairs $(x_1, y_1), (x_2, y_2), \dots, (x_n, y_n), \dots$. The pair (x_i, y_i) , values of the variables for i^{th} observation. For example X denotes demand of the commodity and Y denotes price of the commodity then x_i denotes demand of i^{th} commodity and y_i denotes price of i^{th} commodity.



Let's Learn

5.1 Concept of Correlation

In a bivariate data, we may be interested in finding if there is any relationship or association between the two variables. "A correlation is a measure of association or relation". If we observe in the bivariate data the changes in one variable are accompanied by changes in the other variable then the two variables are said to be correlated. In this case we say that there is a correlation between two underlying variables.

For example,

- i) Intelligence Quotient (IQ) and marks of a student.
- ii) Demand and price of a commodity.



Let's discuss:

5.2 Covariance:-

Covariance is a measure of joint variation between the two variables. If $(x_1, y_1), (x_2, y_2), (x_n, y_n)$ are n ordered pairs of values of x and y , then covariance between X and Y is defined by

$$\text{cov}(x, y) = \frac{1}{n} \sum_{i=1}^n (x_i - \bar{x})(y_i - \bar{y}),$$

$$\text{where } \bar{x} = \frac{\sum x_i}{n} \text{ and } \bar{y} = \frac{\sum y_i}{n}.$$

The above formula can be simplified as follows :

$$\begin{aligned} \text{cov}(x, y) &= \frac{1}{n} \sum_{i=1}^n (x_i - \bar{x})(y_i - \bar{y}) \\ &= \frac{1}{n} \sum_{i=1}^n (x_i y_i - x_i \bar{y} - \bar{x} y_i + \bar{x} \bar{y}) \end{aligned}$$

$$\begin{aligned}
&= \frac{1}{n} \left[\sum_{i=1}^n x_i y_i - \bar{y} \sum_{i=1}^n x_i - \bar{x} \sum_{i=1}^n y_i + \sum_{i=1}^n \bar{x} \bar{y} \right] \\
&= \frac{1}{n} \left[\sum_{i=1}^n x_i y_i \right] - \left[\bar{y} \bar{x} - \bar{x} \bar{y} + \bar{x} \bar{y} \right] \\
&= \frac{1}{n} \sum_{i=1}^n x_i y_i - \bar{x} \bar{y}
\end{aligned}$$

This formula is used in practice.

5.3 Properties of covariance:

- (i) $\text{Cov}(X, Y) = \text{Cov}(Y, X)$
- (ii) $\text{Cov}(X, C) = 0$ where C is a constant
- (iii) Covariance may be positive, negative or zero.
- (iv) $\text{Cov}(X, X) = \text{Var}(X)$
- (v) Covariance is invariant under change of origin but is affected by change of scale.

That is if $U = \frac{x-a}{h}$ and $V = \frac{y-b}{k}$, where

a, b, h, k are constants and $h \neq 0, k \neq 0$ then,

$$\text{Cov}(U, V) = \frac{1}{hk} \text{Cov}(X, Y)$$

$$\text{Cov}(X, Y) = hk \text{Cov}(U, V)$$

Note that these are standard deviations of X and Y respectively.

$$\sigma_x = \sqrt{\frac{1}{n} \sum_{i=1}^n (x_i - \bar{x})^2} = \sqrt{\frac{1}{n} \sum_{i=1}^n x_i^2 - \bar{x}^2}$$

$$\sigma_y = \sqrt{\frac{1}{n} \sum_{i=1}^n (y_i - \bar{y})^2} = \sqrt{\frac{1}{n} \sum_{i=1}^n y_i^2 - \bar{y}^2}$$

Compare and understand the difference between variance and co-variance.

5.4 Correlation coefficient:-

Karl Pearson (1867-1936) developed a measure for the degree of relation between two variables. This measure is called correlation coefficient.

Correlation coefficient between two random variables X and Y denoted by r_{xy} or $r(x, y)$ is defined by

$$r_{xy} = \frac{\text{cov}(x, y)}{\sigma_x \sigma_y}$$

Properties of correlation coefficient $r(x, y)$:-

- (i) $r_{xy} = r_{yx}$ (order of variable is not important).
- (ii) Change of origin and scale :
Correlation coefficient (r) does not change its magnitude under the change of origin and scale.
- (iii) But if one of the change of scale has Negative sign then correlation coefficient becomes negative.
Correlation $\left(\frac{x-a}{h}, \frac{y-b}{k} \right) = \text{Correlation}(x, y)$
if h, k has same algebraic sign $r_{uv} = r_{xy}$ also
 $h, k \neq 0, r_{uv} = -r_{xy}$ if h, k have opposite algebraic sign
- (iv) Correlation $(x, x) = 1$.
- (v) r lies between -1 and 1 that is $-1 \leq r \leq 1$

5.5 Scatter Diagram:-

A scatter diagram is a graphical method of presenting bivariate data (grouped and ungrouped).

Correlation can be observed in a scatter diagram.

Following are examples of different situations given different types of scatter diagrams.

(I) a) Perfect positive correlation:-

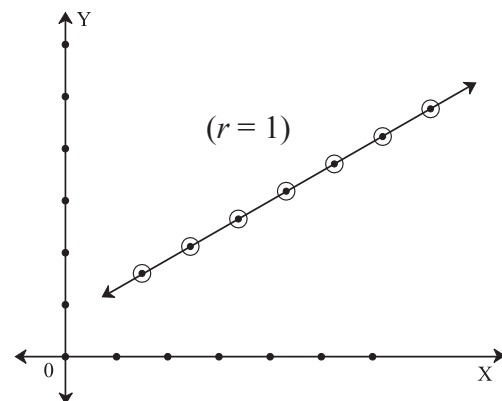

Fig 5.1

If the points are rising from left to right in a straight line then scatter diagram indicates a perfect positive correlation.

b) Positive correlation with high degree:-

If the band is rising from left to right then it indicates positive correlation. If the width of the band is smaller, then the correlation is of high degree.

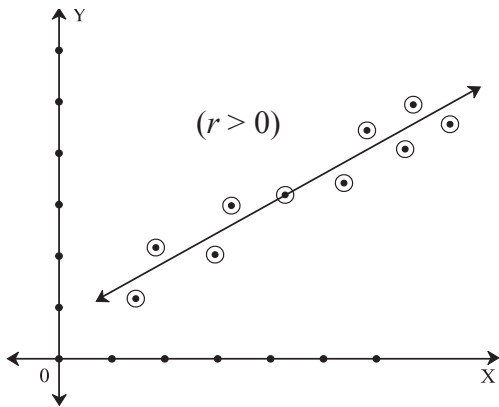

Fig 5.2

c) Positive correlation with low degree:-

If the band is rising from left to right then it indicates positive correlation. If the width of the band is bigger, then the correlation is of low degree.

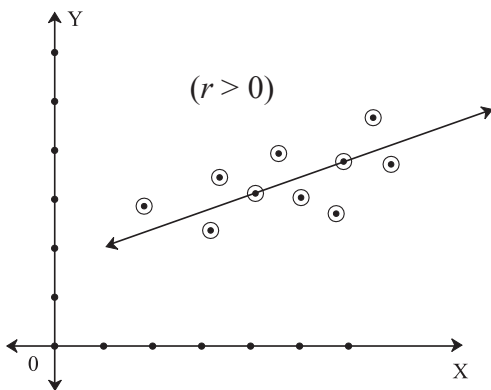

Fig 5.3

(II) a) Perfect negative correlation:-

If the points are falling from left to right in a straight line then scatter diagram indicates a perfect negative correlation.

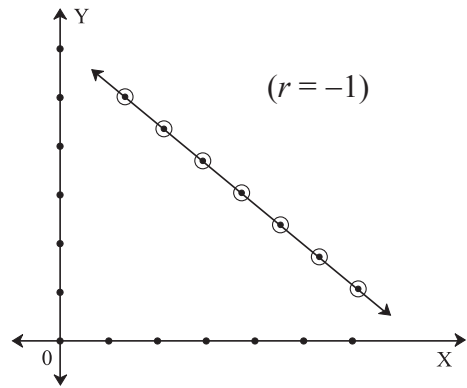

Fig 5.4

b) Negative correlation with high degree:-

If the band is falling down from left to right it indicates negative correlation. If the width of the band is smaller, then the correlation is of high degree.

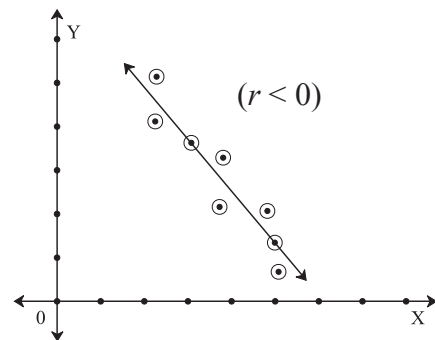

Fig 5.5

c) Negative correlation with low degree:-

If the band is falling down from left to right it indicates negative correlation. If the width of the band is bigger then the correlation is of low degree.

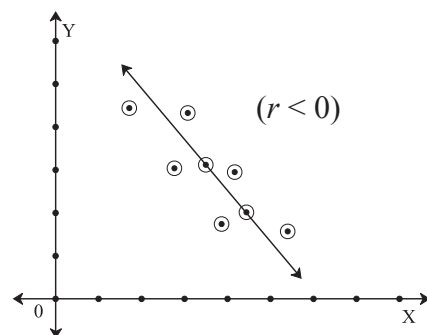

Fig 5.6

(III) No correlation (Zero correlation):-

In this case no trend line is observed.

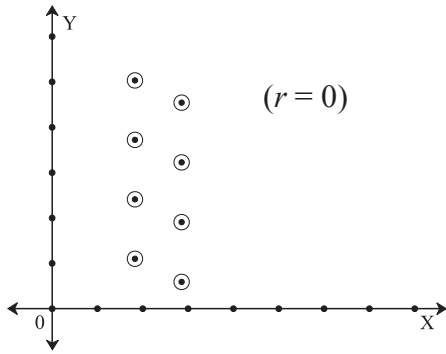

Fig 5.7

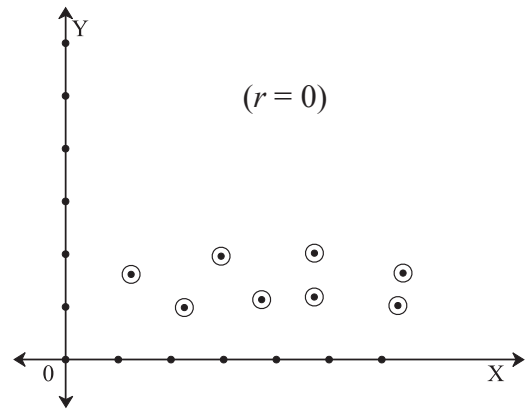

Fig 5.10

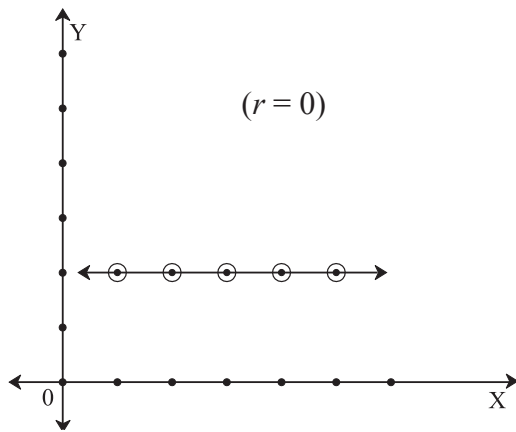

Fig 5.8

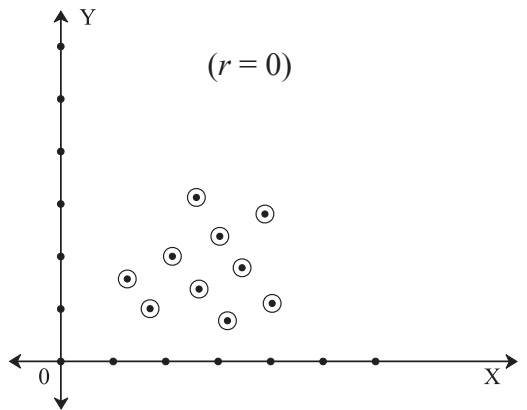

Fig 5.11

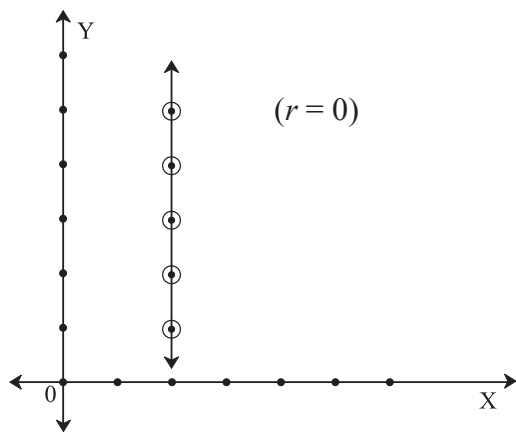

Fig 5.9

5.6 Interpretation of value of correlation coefficient:-

If $r > 0$, the correlation is positive.

If $r < 0$, the correlation is negative.

If $r = 0$, there is no correlation.

If $r > 0.8$, there is high positive correlation.

If $0.3 < r < 0.8$, there is moderate positive correlation.

If $|r| < 0.3$, the correlation is insignificant or poor.

If $r = 1$, the correlation is perfect positive.

If $r = -1$, the correlation is perfect negative.

Alternative formula of correlation coefficient:-

$$(i) \quad r = \frac{\Sigma(x - \bar{x})(y - \bar{y})}{\sqrt{(\Sigma(x - \bar{x})^2) \Sigma(y - \bar{y})^2}}$$

when \bar{x} , \bar{y} are integers & small nos.

$$(ii) \quad r = \frac{n\Sigma xy - \Sigma x \Sigma y}{\sqrt{n\Sigma x^2 - (\Sigma x)^2} \times \sqrt{n\Sigma y^2 - (\Sigma y)^2}}$$

when \bar{x} , \bar{y} are decimals Σx , Σy are comparatively small nos.

(iii) For change of origin & scale

$$r_{uv} = \frac{n\Sigma uv - \Sigma u \Sigma v}{\sqrt{n\Sigma u^2 - (\Sigma u)^2} \times \sqrt{n\Sigma v^2 - (\Sigma v)^2}}$$

SOLVED EXAMPLES

1) A train travelled between two stations and distance and time were recorded as below,

Distance(km)	80	120	160	200	240
Time(Hr)	2	3	4	5	6

Draw scatter diagram and identify the type of correlation.

Solution: Here we take distance on X- axis and Time on Y- axis and plot the points as below,

Graph:-

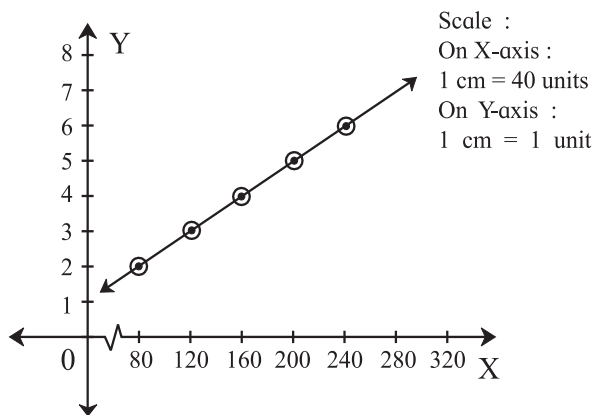

Fig 5.12

Since all the points lie on the straight line rising from left to right, there is perfect positive correlation between distance and time for the train.

2) Draw scatter diagram for the following data and identify the type of correlation.

Capital (in crores Rs.)	2	3	4	5	6	8	9
Profit (in lakh Rs.)	6	5	7	7	8	9	10

Solution: Here we take capital on X- axis and profit on Y- axis and plot the points as below,

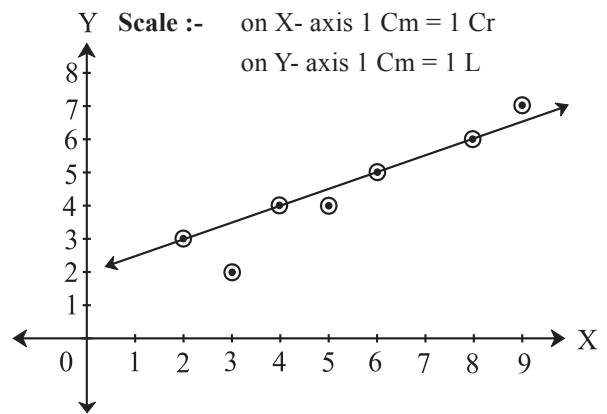

Fig 5.13

We get a band of points rising left to right. This indicates the positive correlation between capital and profit.

3) Compute correlation coefficient for the following data,

$$n = 100, \bar{x} = 62, \bar{y} = 53, \sigma_x = 10, \sigma_y = 12, \Sigma(x_i - \bar{x})(y_i - \bar{y}) = 8000.$$

Solution: Given that $n = 100, \bar{x} = 62, \bar{y} = 53, \sigma_x = 10, \sigma_y = 12,$
 $\Sigma(x_i - \bar{x})(y_i - \bar{y}) = 8000.$

For finding correlation coefficient, we require cov(x,y) and σ_x and σ_y

$$\begin{aligned} \text{cov}(x,y) &= \frac{1}{n} \sum (x_i - \bar{x})(y_i - \bar{y}) \\ &= \frac{8000}{100} \\ &= 80. \\ r &= \frac{\text{cov}(x,y)}{\sigma_x \sigma_y} = \frac{80}{10 \times 12} = 0.67 \end{aligned}$$

- 4) Find correlation coefficient between x and y for the following data and interpret it.

x	1	2	3	4	5	6	7	8	9
y	12	11	13	15	14	17	16	19	18

$$(\sqrt{666} = 25.80)$$

Solution: For finding correlation coefficient, we require $\text{cov}(x,y)$ and x and y . We construct the following table,

x_i	y_i	x_i^2	y_i^2	$x_i y_i$
1	12	1	144	12
2	11	4	121	22
3	13	9	169	39
4	15	16	225	60
5	14	25	196	70
6	17	36	289	102
7	16	49	256	112
8	19	64	361	152
9	18	81	324	162
Total 45	135	285	2085	731

Table 5.1

From table we have,

$$\sum x_i = 45, \sum y_i = 135, \sum x_i^2 = 285, \sum y_i^2 = 2085, \sum x_i y_i = 731.$$

$$\therefore \bar{x} = \frac{\sum x_i}{n} = \frac{45}{9} = 5, \bar{y} = \frac{\sum y_i}{n} = \frac{135}{9} = 15.$$

$$\begin{aligned} \text{cov}(x,y) &= \frac{1}{n} \sum x_i y_i - \bar{x} \bar{y} = \frac{731}{9} - (5)(15) \\ &= 81.22 - 75 = 6.22. \end{aligned}$$

$$\sigma_x = \sqrt{\frac{1}{n} \sum_{i=1}^n x_i^2 - (\bar{x})^2} = \sqrt{\frac{285}{9} - 5^2}$$

$$= \sqrt{31.66 - 25} = \sqrt{6.66} = 2.580$$

$$\sigma_y = \sqrt{\frac{1}{n} \sum_{i=1}^n y_i^2 - (\bar{y})^2} = \sqrt{\frac{2085}{9} - 15^2}$$

$$= \sqrt{231.66 - 225} = \sqrt{6.66} = 2.58$$

$$r_{xy} = \frac{\text{cov}(x,y)}{\sigma_x \sigma_y} = \frac{6.22}{\sqrt{6.66} \sqrt{6.66}} = \frac{6.22}{6.66} = 0.93$$

There is high degree positive correlation between x and y .

- 5) Calculate correlation coefficient from the following data,

$$n = 10, \sum x_i = 140, \sum y_i = 150, \sum (x_i - 10)^2 = 180, \sum (y_i - 15)^2 = 500, \text{ and}$$

$$\sum (x_i - 10)(y_i - 15) = 60.$$

Solution: We are given that $\sum x_i = 140, \sum y_i = 150, \sum (x_i - 10)^2 = 180, \sum (y_i - 15)^2 = 500,$ and $\sum (x_i - 10)(y_i - 15) = 60.$

Let us define $u_i = x_i - 10$ and $v_i = y_i - 15$, then we have,

$$\begin{aligned} \sum u_i &= \sum (x_i - 10) = \sum x_i - \sum 10 = \sum x_i - 10n \\ &= 140 - 10 \times 10 = 40. \end{aligned}$$

$$\begin{aligned} \sum v_i &= \sum (y_i - 15) = \sum y_i - \sum 15 = \sum y_i - 15n \\ &= 150 - 150 = 0. \end{aligned}$$

$$\sum u_i^2 = \sum (x_i - 10)^2 = 180.$$

$$\sum v_i^2 = \sum (y_i - 15)^2 = 500.$$

$$\sum u_i v_i = \sum (x_i - 10)(y_i - 15) = 60.$$

$$\bar{u} = \frac{\sum u_i}{n} = \frac{40}{10} = 4, \bar{v} = \frac{\sum v_i}{n} = \frac{0}{10} = 0.$$

$$\sigma_u = \sqrt{\frac{1}{n} \sum_{i=1}^n u_i^2 - \bar{u}^2} = \sqrt{\frac{180}{10} - 4^2}$$

$$= \sqrt{18 - 16} = \sqrt{2}$$

$$\sigma_v = \sqrt{\frac{1}{n} \sum_{i=1}^n v_i^2 - \bar{v}^2} = \sqrt{\frac{500}{10} - 0^2}$$

$$= \sqrt{50-0} = \sqrt{50}$$

$$\therefore \text{cov}(u,v) = \frac{1}{n} \sum u_i v_i - \bar{u} \bar{v} = \frac{60}{10} - (4)(0) = 6$$

$$r_{uv} = \frac{\text{cov}(u,v)}{\sigma_u \sigma_v} = \frac{6}{\sqrt{2} \sqrt{50}} = 0.6$$

But $r_{xy} = r_{uv} = 0.6$.

- 6) Find correlation coefficient between x and y for the following data

$$n = 25, \sum x_i = 75, \sum y_i = 100, \sum x_i^2 = 250, \sum y_i^2 = 500, \sum x_i y_i = 325.$$

Solution- We are given that, $n = 25, \sum x_i = 75, \sum y_i = 100, \sum x_i^2 = 250, \sum y_i^2 = 500, \sum x_i y_i = 325$.

$$\therefore \bar{x} = \frac{\sum x_i}{n} = \frac{75}{25} = 3. \quad \bar{y} = \frac{\sum y_i}{n} = \frac{100}{25} = 4.$$

$$\sigma_x = \sqrt{\frac{1}{n} \sum_{i=1}^n x_i^2 - (\bar{x})^2} = \sqrt{\frac{250}{25} - 3^2}$$

$$= \sqrt{10-9} = 1$$

$$\sigma_y = \sqrt{\frac{1}{n} \sum_{i=1}^n y_i^2 - (\bar{y})^2} = \sqrt{\frac{500}{25} - 4^2}$$

$$= \sqrt{20-16} = \sqrt{4} = 2$$

$$\therefore \text{cov}(x,y) = \frac{1}{n} \sum x_i y_i - \bar{x} \bar{y} = \frac{325}{25} = (3)(4)$$

$$= 13 - 12 = 1$$

$$r_{xy} = \frac{\text{cov}(x,y)}{\sigma_x \sigma_y} = \frac{1}{2} = 0.5$$

- 7) Calculate correlation coefficient between age of husbands and age of wives.

Age of husbands	23	27	28	29	30	31	33	35	36	39
Age of wives	18	22	23	24	25	26	28	30	31	34

Solution: Here the change of origin and scale property can be used to find the correlation coefficient. We construct the table as below,

x_i	y_i	$u_i = x_i - 31$	$v_i = y_i - 25$	u_i^2	v_i^2	$u_i v_i$
23	18	-8	-7	64	49	56
27	22	-4	-3	16	9	12
28	23	-3	-2	9	4	6
29	24	-2	-1	4	1	2
30	25	-1	0	1	0	0
31	26	0	1	0	1	0
33	28	2	3	4	9	6
35	30	4	5	16	25	20
36	31	5	6	25	36	30
39	34	8	9	64	81	72
Total -	-	1	11	203	215	204

Table 5.2

From table we have,

$$\sum u_i = 1, \quad \sum v_i = 11, \quad \sum u_i^2 = 203, \quad \sum v_i^2 = 215,$$

$$\sum u_i v_i = 204.$$

$$\bar{u} = \frac{\sum u_i}{n} = \frac{1}{10} = 0.1. \quad \bar{v} = \frac{\sum v_i}{n} = \frac{11}{10} = 1.1.$$

$$\therefore \text{cov}(u,v) = \frac{1}{n} \sum u_i v_i - \bar{u} \bar{v}$$

$$= \frac{204}{10} - (0.1)(1.1) = 20.4 - 0.11 = 20.29$$

$$\sigma_x = \sqrt{\frac{1}{n} \sum_{i=1}^n u_i^2 - \bar{u}^2} = \sqrt{\frac{203}{10} - 0.1^2}$$

$$= \sqrt{20.3 - 0.01} = \sqrt{20.29}$$

$$\sigma_y = \sqrt{\frac{1}{n} \sum_{i=1}^n v_i^2 - \bar{v}^2} = \sqrt{\frac{215}{10} - 1.1^2}$$

$$= \sqrt{21.5 - 1.21} = \sqrt{20.29}$$

$$r_{uv} = \frac{\text{cov}(x,y)}{\sigma_x \sigma_y} = \frac{20.29}{\sqrt{20.29} \sqrt{20.29}} = 1$$

But $r_{xy} = r_{uv} = 1$

EXERCISE 5.1

- 1) Draw scatter diagram for the data given below and interpret it.

x	10	20	30	40	50	60	70
y	32	20	24	36	40	28	38

- 2) For the following data of marks of 7 students in Physics (x) and Mathematics (y), draw scatter diagram and state the type of correlation.

x	8	6	2	4	7	8	9
y	6	5	1	4	4	7	8

- 3) Draw scatter diagram for the data given below. Is there any correlation between Aptitude score and Grade points?

Aptitude score	40	50	55	60	70	80
Grade points	1.8	3.8	2.8	1.7	2.8	3.2

- 4) Find correlation coefficient between x and y series for the following data
 $n = 15$, $\bar{x} = 25$, $\bar{y} = 18$, $\sigma_x = 3.01$, $\sigma_y = 3.03$,

$$\Sigma(x_i - \bar{x})(y_i - \bar{y}) = 122.$$

- 5) The correlation coefficient between two variables x and y is 0.48. The covariance is 36 and the variance of x is 16. Find the standard deviation of y .

- 6) In the following data one of the value of y is missing. Arithmetic means of x and y series are 6 and 8 respectively. ($\sqrt{2} = 1.4142$)

x	6	2	10	4	8
y	9	11	?	8	7

- (i) Estimate missing observation
 (ii) Calculate correlation coefficient.

- 7) Find correlation coefficient from the following data, [Given : $\sqrt{3} = 1.732$]

X	3	6	2	9	5
Y	4	5	8	6	7

- 8) Correlation coefficient between x and y is 0.3 and their covariance is 12. The variance of x is 9, find the standard deviation of y .



Let's Remember

- 1) Bivariate data is the observation recorded on two variables.
- 2) Correlation is the study of mutual or joint relationship between two variables.
- 3) There are 3 types of correlation,
 - i) Positive correlation
 - ii) Negative correlation
 - iii) No correlation.
- 4) Correlation coefficient between the variables

$$x \text{ and } y \text{ is given by } r_{xy} = \frac{\text{cov}(x, y)}{\sigma_x \sigma_y}$$

- 5) $-1 \leq r \leq 1$.
- 6) Numerical value of correlation coefficient is invariant to the change of origin and scale.

$$7) \text{cov}(x, y) = \frac{1}{n} \Sigma(x_i - \bar{x})(y_i - \bar{y})$$

$$= \frac{1}{n} \Sigma x_i y_i - \bar{x} \bar{y}$$

MISCELLANEOUS EXERCISE

- 1) Two series of x and y with 50 items each have standard deviations 4.8 and 3.5 respectively. If the sum of products of deviations of x and y series from respective arithmetic means is 420, then find the correlation coefficient between x and y .
- 2) Find the number of pairs of observations from the following data,
 $r = 0.15$, $\sigma_y = 4$, $\Sigma(x_i - \bar{x})(y_i - \bar{y}) = 12$,
 $\Sigma(x_i - \bar{x})^2 = 40$.

- 3) Given that $r = 0.4$, $\sigma_x = 3$,
 $\Sigma(x_i - \bar{x})(y_i - \bar{y}) = 108$, $\Sigma(x_i - \bar{x})^2 = 900$.
 Find the number of pairs of observations.
- 4) Given the following information, $\Sigma x_i^2 = 90$,
 $\Sigma x_i y_i = 60$, $r = 0.8$, $\sigma_y = 2.5$, where x_i and
 y_i are the deviations from their respective
 means. Find the number of items.
- 5) A sample of 5 items is taken from the
 production of a firm. Length and weight of
 5 items are given below,
 [Given : $\sqrt{0.8823} = 0.9393$]

Length(cm)	3	4	6	7	10
Weight(gm.)	9	11	14	15	16

Calculate correlation coefficient between
 length and weight and interpret the result.

- 6) Calculate correlation coefficient from the
 following data, and interpret it.

X	1	3	5	7	9	11	13
Y	12	10	8	6	4	2	0

- 7) Calculate correlation coefficient from the
 following data and interpret it.

x	9	7	6	8	9	6	7
y	19	17	16	18	19	16	17

- 8) If the correlation coefficient between x and
 y is 0.8, what is the correlation coefficient
 between i) $2x$ and y ii) $\frac{x}{2}$ and y iii) x and
 $3y$ iv) $x-5$ and $y-3$ v) $x+7$ and $y+9$ vi)
 $\frac{x-5}{7}$ and $\frac{y-3}{8}$?

- 9) In the calculation of the correlation
 coefficient between height and weight
 of a group of students of a college, one
 investigator took the measurements in inches
 and pounds while the other investigator
 took the measurements in cm. and kg. Will
 they get the same value of the correlation
 coefficient or different values? Justify your
 answer.

Activity 5.1

Calculate the correlation coefficient between
 weight and height in Activity 4.2

Activity 5.2

Calculate the correlation coefficient between
 age (in years) and blood pressure from
 Exercise 4 of Miscellaneous 4.

Activity 5.3

Using the given data plot the points & draw
 the scatter diagram. And identify the type of
 correlation.

X	8	12	16	20	24	28	32
Y	2	3	4	5	6	7	8

Activity 5.4

Select any 2 stocks and record the share
 prices for 10 days. Draw the scatter diagram
 of them.



6. PERMUTATIONS AND COMBINATIONS



Let's Study

- ◆ Fundamental principles of counting
- ◆ Factorial function
- ◆ Permutations
- ◆ Combinations



Let's Recall

1. The number system.
2. The four basic mathematical operations: addition, subtraction, multiplication, division.

INTRODUCTION

Counting is a fundamental activity in mathematics. Learning to count was our first step in learning mathematics. After learning to count objects one by one, we used operations of addition and multiplication to make counting easy. We shall now learn two more methods of counting to make counting easier. These two methods are known as permutations and combinations. Permutations refer to the number of different rearrangements of given objects, when the order of objects in the arrangements is important. Combinations are related to the number of different selections from a given set of objects, when the order of objects in the selections is not important.

The theory of permutations and combinations forms the basis of many topics of mathematics, including number theory, graph theory, discrete mathematics, algebra, geometry, probability, and other disciplines like statistics, cryptology, security

systems, and so on. The theory of permutations and combinations is central in problems of counting such a large number of objects that it is impossible to count them manually. The theory of permutations and combinations enables us to count objects without listing or enumerating them.

Let us begin with the following simple example. Every smartphone requires a password to unlock it. A password is formed by four of the ten digits on the screen. The order of these four digits cannot be changed for password to work. How many distinct passwords are possible? In other words, how many users can have distinct passwords? Note that a password consists of four digits. The first digit of a password can be any of the ten digits, the second digit can be any of the ten digits, and similarly for the third and fourth digits. This gives a total of $10 \times 10 \times 10 \times 10 = 10,000$ as the number of distinct possible passwords.

Consider one more example which is not as easy as the last example. The school cricket team has eleven players. The school wants a photograph of these players, along with the principal and the two vice principals of the school, for school magazine. Seven chairs are arranged in a row for the photograph. Three chairs in the middle are reserved for the principal and the two vice principals. Four players will occupy the remaining four chairs and seven players will stand behind the chairs. The question then is: "In how many different ways can the eleven players take positions for the photograph?" This example

will be considered later in the chapter. Till then, we can try, on our own, to find the number of different ways in which the eleven players can sit or stand for the photo.



Let's Learn

We shall begin by learning some techniques that are useful in counting such arrangements without actually writing them down. Since this chapter is related to counting, we must understand three principles of counting that are fundamental to all methods of counting, including permutations and combinations.

6.1 Fundamental principles of counting

We have learnt in set theory that subsets of a set can be represented diagrammatically in the form of a Venn diagram. An alternative method is to draw a tree diagram if the subsets are disjoint. For example, the English alphabet has 26 letters from A to Z. These 26 letters can be divided in two groups: 5 vowels and 21 consonants. This division can be presented diagrammatically as follows.



Fig. 6.1

Diagrams of this nature are called tree diagrams. A tree diagram shows the division of a set into disjoint subsets. A complete tree diagram shows different possible divisions of a given set. If the given set represents an action, then the branches of the tree represent different possible outcomes of the action. If the given set consists of objects, then the branches of the tree represent a division

of the set according to some characteristic of the objects. If we are studying an experiment, then the branches represent different possible outcomes of the experiment. The collection of all possible outcomes of an experiment is called its Sample space. Can we think of some examples where tree diagrams can be used?

Tree diagrams, along with the fundamental principles of counting, are powerful tools in counting the total number of possible outcomes of an experiment. The fundamental principles of counting use additions or multiplications to determine the total number of outcomes. The fundamental principles of counting provide an efficient way of finding the number of different ways to carry out two or more activities, either simultaneously or successively (that is, one after another).

The fundamental principles of counting can be effectively used for determining the number of possible outcomes when two or more characteristics are involved. Consider the situation where a boy wants to go for shopping on Sunday. He wants to wear a good shirt when he goes for shopping. He has three T-shirts of three different colours: white, gray, and blue. He also has four shirts of four different colours: red, green, yellow, and orange. How many choices does he have to wear? For this, the boy must first decide whether he wants to wear a shirt or a T-shirt. If he decides to wear a shirt, then he has four choices. If he decides to wear a T-shirt, then he has three choices. This situation can be represented using a tree diagram as follows.

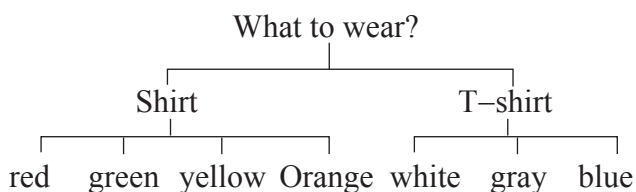

Fig. 6.2

The tree diagram shows that the boy has seven choices in all. These seven choices can be presented in the form of a list as follows.

1. Red shirt
2. Green shirt
3. Yellow shirt
4. Orange shirt
5. White T-shirt
6. Gray T-shirt
7. Blue T-shirt

This example shows that the total number of outcomes is obtained by adding the number of outcomes of each characteristic when only one characteristic can be chosen. This is called the addition principle of counting, which is one of the fundamental principles of counting.

6.1.1 ADDITION PRINCIPLE

Consider a situation where Raju has 3 red shirts (R1, R2, R3) and 2 green shirts (G1, G2). When Raju wants to wear a shirt, he has to first select the colour (red or green) and then a shirt of the chosen colour. Can we find the number of ways Raju can select a shirt to wear?

Let us try to imagine what Raju must be thinking. Do we also think in the following way?

Raju has to perform the following tasks: (i) select a red shirt, or (ii) select a green shirt. He, however, cannot select two shirts. Let us answer one question at a time to understand the situation.

Q.1 In how many ways can the first task be accomplished?

Ans. The first task (of selecting the colour) can be accomplished in two ways.

Q.2 In how many ways can the second task be accomplished?

Ans. The answer depends on the outcome of the first task in the following way.

If the red colour is selected in the first task, then the second task can be accomplished in three ways.

If the green colour is selected in the first task, then the second task can be accomplished in two ways.

Q.3 As the result of accomplishing the two tasks, how many ways are available for selecting a shirt?

Ans. The total number of ways available for selecting a shirt is $3 + 2 = 5$.

This brings us to the first fundamental principle of counting, the addition principle, which can be stated as follows.

Definition of Addition Principle.

If one event can occur in m ways and the second event with no common outcomes can occur in n ways, then either of the two events can occur in $m + n$ ways.

Ex. 1 : A restaurant offers five types of cold drinks and three types of hot drinks. If a customer wants to order a drink, how many choices does the customer have?

Solution : Since the restaurant offers five cold drinks, the customer has five ways of selecting a cold drink. Similarly, since the restaurant offers three types of hot drinks, the customer has three

ways of selecting a hot drink. Finally, since the customer wants to select only one drink, there are $5 + 3 = 8$ choices for the customer.

Consider one more example where the addition principle is used. Consider an experiment of drawing a card from a pack of 52 cards. What is the number of ways in which the drawn card is a spade or a club?

How can we find this number? Do we think in the same way as follows?

In the given situation, any one of the following two operations can be performed.

- (i) Select a spade card out of the 13 spade cards in the deck.
- (ii) Select a club card out of the 13 club card in the deck.

Q.1 In how many ways can the first operation be performed?

Ans. The first operation can be performed in $m = 13$ ways.

Q.2 In how many ways can the second operation be performed?

Ans. The second operation can be performed in $n = 13$ ways.

Q.3 Is it possible to perform both the operations?

Ans. No. Only one of the two operations can be performed in the experiment.

Q.4 How many ways are then available for selecting a card that satisfies the specified condition (that the selected card is a spade or a club)?

Ans. There are $m + n = 13 + 13 = 26$ ways of selecting a card which is a spade or a club.

6.1.2 MULTIPLICATION PRINCIPLE

Now, consider the following situation. An Ice Cream is served either in a cup or in a cone. Also, Ice Cream is available in three flavours: vanilla, chocolate, and strawberry. This information can be represented in the form of a tree diagram as follows.

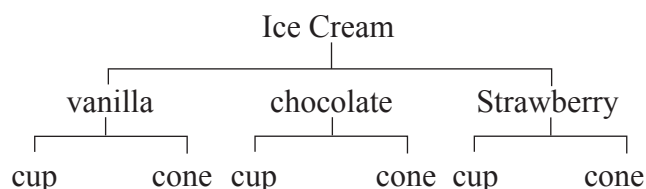

Fig. 6.3

The tree diagram in above figure shows the six different ways in which Ice Cream can be served. Can we think of a different tree diagram to represent the same information? Do we think that the following tree diagram also represents the same information?

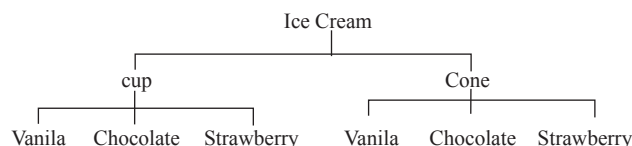

Fig. 6.4

Note that both the tree diagrams show that there are six possible outcomes, that is, six ways to serve Ice Cream. What do we understand from these two tree diagrams about counting the possible outcomes? Do we think as follows?

When the final decision depends on two decisions, say D_1 and D_2 , to be taken one after the other, first determine the number of outcomes of D_1 and D_2 separately. Suppose D_1 has n_1 outcomes and D_2 has n_2 outcomes. If D_1 and D_2 are decisions that are taken one after the other, then the total

number of possible decisions is obtained by multiplication, so that there are $n_1 \times n_2$ possible outcomes, as can also be observed in the two tree diagrams in Fig.6.3 and Fig. 6.4.

In the example of Ice Cream, the final count of six is obtained by multiplying 3 (number of flavours) by 2 (number of serving options), in either order.

If there are more than two decisions, then we continue to multiply the number of options in one decision after another. This method of multiplication is relevant when these decisions are to be taken one after another.

Ex. 2 : Samadhan Bhojanalay offers a thali that has five items: roti, rice, vegetable, dal, and pickle. Following choices are available and one option is to be selected for each item.

Roti: tawa roti, chapati, tandoor roti

Rice: plain rice, steamed rice, jeera rice, dal khichadi

Vegetable: dum aloo, paneer masala, mixed veg

Dal: dal fry, dal tadka, kadhi

Pickle: lemon, mango, mirchi

How many different menus (that is, combinations) are possible?

Solution : Since one option is to be selected for each item, the number of different possible thali choices are identified as follows.

Roti 3, Rice 4, Vegetable 3, Dal 3, Pickle 3, and hence the total number of different possible thali menus is $3 \times 4 \times 3 \times 3 \times 3 = 324$. Do we think it necessary to write down all the 324 choices in order to count them?

Ex. 3 : A company decides to label each of its different products with a code that consists of two letters followed by three digits. How many different products can be labeled in this way?

Solution : Since the first two characters in a label are letters, they can be formed in $26 \times 26 = 676$ ways. The next three characters are digits and can be formed in $10 \times 10 \times 10 = 1000$ ways. The total number of distinct labels is, by the multiplication principle, given by $676 \times 1000 = 6,76,000$.

Ex. 4 : Dhaniram went to buy a car. The showroom has two body styles (sedan and hatchback), five different colors (black, red, green, blue, and white), and three different model standard model, (GL), sports model, (SS), and luxury model, (SL).

- (i) How many different choices does Dhaniram have? (Activity)
- (ii) If he is told that black color is not available for a sedan, then how many different choices remain available to Dhaniram? (Activity)

Now, consider the situation where Govinda has four shirts (white, yellow, pink, and green) and three pants (black, red, and maroon). Govinda wants to wear a shirt and a pant to attend a function. How many ways does he have for selecting his dress? Let us think over this problem and try to help Govinda in his selection.

Do we proceed in the same direction as shown by the following argument?

Let us denote the four shirts by four letters W, Y, P, and G. Similarly, let us denote the three

pants by three letters B, R, and M. Then the possible selections for Govinda can be listed as follows. (W, B), (W, R), (W, M), (Y, B), (Y, R), (Y, M), (P, B), (P, R), (P, M), (G, B), (G, R), (G, M). The list shows that Govinda has a total of 12 choices for selecting his dress. This finding can be stated in the following form. Govinda has $m = 4$ shirts and $n = 3$ pants. Since he wants to select one shirt and one pant, he has $m \times n = 4 \times 3 = 12$ ways to make the selection.

All these examples bring us to the multiplication principle, the second fundamental principle of counting.

Definition of Multiplication Principle

If one operation can be carried out in m ways, and the second operation can be carried out in n ways, then both the operations can be carried out in $m \times n$ ways.

Consider one more example for better understanding of the multiplication principle.

Ex. 1 : A card is drawn from a deck of 52 cards and its colour and suit are noted. The card is then put back in the deck and a second card is drawn from the deck and its colour and suit are also noted.

Can we use this information to design the problem of selecting a club card and a spade card in the two draws? After studying the problem carefully, can we also obtain its solution? Do we get something similar to what follows?

Define the first event as obtaining a club card on the first draw and second event as obtaining a spade card on the second draw. Note that the first card is drawn from the deck of 52 cards. The second card is also drawn from the deck of 52

cards because the first card is put back in the deck after noting its colour and suit. The first event can occur in $m = 13$ ways because there are 13 club cards in the deck of 52 cards. The second event can also occur in $n = 13$ ways because there are 13 spade cards in the deck. The total number of ways in which one club card and one spade card are drawn, when the drawn card is put back before the second draw, is then given by

$$m \times n = 13 \times 13 = 169.$$

Let us try to solve the following examples for practice.

Ex. 2 : Suresh has 4 pencils and 2 erasers. He wants to take one pencil and one eraser for the examination. Can we find the number of ways in which he can select a pencil and an eraser?

Ex. 3 : Sunil has 4 ball pens of one company and 3 ball pens of another company. In how many ways can he select a ball pen?

In the above examples, can we decide when to use the addition principle and when to use the multiplication principle? Can we give reasons? What are answers in the above examples?

Remark: The addition and multiplication principles can be extended from 2 to any finite number of activities, experiments, events, or operations. For example, the two principles can be stated as follows for three activities.

Addition Principle. If three operations, when conducted simultaneously and independently of one another, can be performed in m , n , and r ways, respectively, then any one of them can be performed in $m + n + r$ different ways.

Multiplication Principle. If an experiment consists of three activities, where activity one has m possible outcomes, activity two has n possible outcomes, and possibility three has r possible outcomes, then the total number of different possible outcomes of carrying out all the 3 activities is $m \times n \times r$.

Let us now solve some more examples using these principles.

Solved Examples

Ex. 1 : Consider the action of drawing a card from a pack of 52 cards. Find the number of ways of selecting a spade or a club card.

Solution:

When a card is drawn from the pack of 52 cards, there are two possible events as described below.

- (i) One of the 13 club cards is selected.
- (ii) One of the 13 spade cards is selected.

Q.1 In how many ways can the first event occur?

Ans. The first event can occur in $m = 13$ ways.

Q.2 In how many ways can the second event occur?

Ans. The second event can occur in $n = 13$ ways.

Q.3 How many different ways are available to select a spade card or a club card?

Ans. Using addition principle the number of ways of selecting a spade card or a club card is $m + n = 26$.

Ex. 2 : Madhavi goes to a shop where she finds three different types of bread, four different types of cheese, three different types of butter, and five different types of jam.

If she can make a sandwich using only one

item of each category, how many different ways does she have to prepare a sandwich?

Solution:

Madhavi can select bread of any one of the three types in three ways. After selecting bread, she can select cheese in four ways, butter in 3 ways, and jam in five ways.

By the principle of multiplication, the total number of ways Madhavi can make her sandwich is $3 \times 4 \times 3 \times 5 = 180$.

Ex. 3 : Five flags are available and they can be arranged on a vertical staff. Find the number of signals that can be created by arranging at least two flags on the staff, one below another.

Solution :

First, let us note that a signal can consist of 2 flags, 3 flags, 4 flags or 5 flags.

Next, let us find the different number of signals that can be created in each of these cases.

The number of signals using two flags is same as the number of different ways of filling two positions using five flags. Since a flag, once used, cannot be used again, the multiplication principle gives the number of different two flag signals to be $5 \times 4 = 20$.

Similarly, the number of different three flag signals is same as the number of different ways of filling three positions, one after another, using 5 flags. By the multiplication principle, this number is $5 \times 4 \times 3 = 60$.

Using the same argument, the number of different four-flag signals is $5 \times 4 \times 3 \times 2 = 120$. Finally, the number of different five-flag signals is $5 \times 4 \times 3 \times 2 \times 1 = 120$.

Putting all these numbers together, the total number of possible different signals is

$$20 + 60 + 120 + 120 = 320.$$

Ex. 4 : There are 6 different routes from city A to city B and 8 different routes from city B to city C. Find the number of different routes if a person wants to travel from city A to city C through city B.

Solution:

A person can choose any one of the 6 different routes to travel from city A to city B. Therefore, he can travel from city A to city B in $m = 6$ different ways. After choosing one of these ways, he can travel from city B to city C in $n = 8$ ways.

Using the multiplication principle, the total number of ways of travelling from city A to city C through city B is $m \times n = 6 \times 8 = 48$.

Ex. 5 : Suppose 5 chocolates are to be distributed among 4 children and there is no condition on how many chocolates a child can get (including zero.) How many different ways are possible for doing so?

Solution:

The first chocolate can be given to any of the four children. Therefore, there are four different ways of giving the first chocolate. Similarly, the second chocolate can be given in four different ways, and similarly for each of the remaining chocolates. The multiplication principle then gives the total number of different ways as

$$4 \times 4 \times 4 \times 4 \times 4 = 4^5 = 1024.$$

Ex. 6 : How many even numbers can be formed using the digits 2, 3, 7, 8 so that the number formed is less than 1000?

Solution:

The condition that the number formed from the given digits is less than 1000 means that this number can have up to 3 digits. Let us therefore consider the three cases separately, namely one digit numbers, two digit numbers and three-digit numbers.

Since the number must be even, the one-digit number can be only 2 or 8. Hence, there are two ways of forming a one digit even number.

Since the required number is even, the units place of a two-digit number must be either 2 or 8. The ten's place can be filled with any of the four given digits. Therefore, there are $4 \times 2 = 8$ ways of forming a two-digit even number.

Finally, since the required number is even, the units place can be filled in two ways, ten's place can be filled in four ways, and hundred's place can also be filled in four ways. The number of ways of forming a three digit even number is $4 \times 4 \times 2 = 32$

The addition principle finally gives the total number of ways of forming an even number less than 1000 using digits 2,3,7,8 is $2+8+32=42$.

EXERCISE 6.1

1. A teacher wants to select the class monitor in a class of 30 boys and 20 girls. In how many ways can he select a student if the monitor can be a boy or a girl?
2. In question 1, in how many ways can the monitor be selected if the monitor must be a boy? What is the answer if the monitor must be a girl?
3. A signal is generated from 2 flags by putting one flag above the other. If 4 flags of different colours are available, how many different signals can be generated?

4. How many two letter words can be formed using letters from the word SPACE, when repetition of letters (i) is allowed, (ii) is not allowed?
5. How many three–digit numbers can be formed from the digits 0, 1, 3, 5, 6 if repetitions of digits (i) are allowed, (ii) are not allowed?
6. How many three–digit numbers can be formed using the digits 2, 3,4,5,6 if digits can be repeated?
7. A letter lock has 3 rings and each ring has 5 letters. Determine the maximum number of trials that may be required to open the lock.
8. In a test that has 5 true/false questions, no student has got all correct answers and no sequence of answers is repeated. What is the maximum number of students for this to be possible?
9. How many numbers between 100 and 1000 have 4 in the units place?
10. How many number between 100 and 1000 have the digit 7 exactly once?
11. How many four digit numbers will not exceed 7432 if they are formed using the digits 2,3,4,7 without repetition?
12. If numbers are formed using digits 2,3,4,5,6 without repetition, how many of them will exceed 400?
13. How many numbers formed with the digits 0,1,2,5,7,8 will fall between 13 and 1000 if digits can be repeated?
14. A school has three gates and four staircases from the first floor to the second floor. How many ways does a student have to go from outside the school to his classroom on the second floor?
15. How many five–digit numbers formed using the digit 0,1,2,3,4,5 are divisible by 3 if digits are not repeated?

We may have noticed in the examples on both the addition principle and the multiplication principle that the two or more activities or operations need not be performed in any fixed order. For example, in the example of Ice Cream, it does not matter if we select the flavour of Ice Cream first and then the serving method or vice versa. The total number of choices is still 6. Similarly, in the example of Raju selecting a shirt, it does not matter whether he makes the list of red shirts first or green shirts first. The number of ways for Raju to select a shirt is still 5. This conclusion is formally known as the third fundamental principle of counting, the invariance principle of counting.

6.2. FACTORIAL FUNCTION.

The theory of permutations and combinations uses a mathematical function known as the factorial function. Let us first understand the factorial function, which is defined for a natural number.

Definition: For a natural number n , the factorial of n , written as $n!$ and read as “ n factorial”, is the product of natural numbers from 1 upto n .

That is, $1 \times 2 \times 3 \dots (n-1) \times n$

Note: The factorial function can also be defined as the product of the first n natural numbers from n to 1.

That is, $n! = n \times (n-1) \times \dots \times 3 \times 2 \times 1$

For this, we must identify all natural numbers from 1 to the given natural number n , and then take their product. For example, if $n = 5$ then we get 1, 2, 3, 4, 5 as the first five natural numbers

and the product of these natural numbers as $5 \times 4 \times 3 \times 2 \times 1 = 120$

This means that “5 factorial is equal to 120.”

Can we extend the concept of product of the first 5 natural numbers to the product of the first n natural numbers? In other words, we must think of $n \times (n - 1) \times (n - 2) \times \dots \times 3 \times 2 \times 1$, where n is the specified natural number.

Let us study the following examples.

Factorial $1 = 1$, $1! = 1$

Factorial $2 = 2 \times 1 = 2$, $2! = 2 \times 1 = 2$

Factorial $3 = 3 \times 2 \times 1 = 6$, $3! = 3 \times 2 \times 1 = 6$

Factorial

$4 = 4 \times 3 \times 2 \times 1 = 24$, $4! = 4 \times 3 \times 2 \times 1 = 24$

and so on.

Note: Factorial is defined for 0 (even though 0 is not a natural number) as $0! = 1$.

Note: It may be interesting to note how the multiplication principle of counting is used to obtain factorial of a natural number. Suppose we want to write the first n natural number in different possible orders. How many ways do we have to do this? It is clear that there are n numbers and they will require n positions. The first position can be filled with any of the n numbers and hence there are n ways of selecting a number for the first position. The second position can be filled with any of the remaining $n - 1$ numbers, and hence there are $n - 1$ ways of selecting a number for the 2nd position. Similarly, there are $(n-2)$ ways of selecting a number for the third position. Continuing in this way, we can see that the total number of ways for writing the first n natural numbers is given by $n!$.

6.2.1 Properties of the factorial function.

- For any positive integer n , $n! = n \times (n - 1)!$
- For any positive integer $n > 1$,
- $n! = n \times (n - 1) \times (n - 2)!$
- For any positive integer $n > 2$,
- $n! = n \times (n - 1) \times (n - 2) \times (n - 3)!$
- (For any positive integers m and n , $(m + n)!$ is always divisible by $m!$ and $n!$)

It is important to remember the following results.

- For any natural numbers m and n , $(m \times n)! \neq m! \times n!$ (Verify)
- For any natural numbers m and n , $(m + n)! \neq m! + n!$
- For any natural numbers m and n with $m > n$, $(m - n)! \neq m! - n!$
- For any natural numbers m and n such that m is divisible by n , $(m \div n)! \neq m! \div n!$

Ex. 1 : Find the value of $7!$

Solution: $7! = 7 \times 6 \times 5 \times 4 \times 3 \times 2 \times 1 = 5040$
(Check)

Ex. 2 : Find $(7-3)!$ and $7! - 3!$

Solution: $(7-3)! = 4! = 4 \times 3 \times 2 \times 1 = 24$.

We have already found $7! = 5040$.

Also, $3! = 3 \times 2 \times 1 = 6$.

$\therefore 7! - 3! = 5040 - 6 = 5034$.

Therefore, we can conclude that $(7-3)! \neq 7! - 3!$

Ex. 3 : Find $8!$, $4!$, and $\frac{8}{4}!$

Solution: Note that $8! = 8 \times 7! = 8 \times 5040 = 40320$. Similarly, $4! = 4 \times 3 \times 2 \times 1 = 24$, and

$$\frac{8}{4}! = 2! = 2 \times 1 = 2.$$

$$\text{Also} = \frac{8!}{4!} = 1680$$

(ii) $(n+3)! = 110 \times (n+1)!$

8. Find n if:

(i) $\frac{n!}{3!(n-3)!} : \frac{n!}{5!(n-5)!} = 5:3$

(ii) $\frac{n!}{3!(n-5)!} : \frac{n!}{5!(n-7)!} = 10:3$

9. Find n if:

(i) $\frac{(17-n)!}{(14-n)!} = 5!$ (ii) $\frac{(15-n)!}{(13-n)!} = 12$

10. Find n if:

$$\frac{(2n)!}{7!(2n-7)!} : \frac{n!}{4!(n-4)!} = 24:1$$

11. Show that

$$\frac{n!}{r!(n-r)!} + \frac{n!}{(r-1)!(n-r+1)!} = \frac{(n+1)!}{r!(n-r+1)!}$$

12. Show that

$$\frac{9!}{3!6!} + \frac{9!}{4!5!} = \frac{10!}{4!6!}$$

13. Find the value of :

(i) $\frac{8! + 5(4!)}{4! - 12}$ (ii) $\frac{5(26!) + (27!)}{4(27!) - 8(26!)}$

14. Show that

$$\frac{(2n)!}{n!} = 2^n (2n-1)(2n-3)\dots 5.3.1$$



Let's Learn

We are now ready to learn the two most popular methods of counting: permutations and combinations. Permutations are ordered arrangements of some or all of the given objects, whereas combinations are selections of a specified number of objects from a given set of objects. Note that in the following discussion, objects can

be persons, things, numbers, letters, symbols, or anything else.

6.3. PERMUTATIONS:

A common question in most of the word problems is to form different words, that may or may not have any meaning, using some or all of the letters in a given collection of letters. For example, consider the problem of finding the number of different words that can be formed by rearranging letters in the word “EXPAND”. Another problem is about the number of different words that can be formed using any two letters in the word “EXPAND”. The first question can be answered by writing down different rearrangements of the letters in the word “EXPAND” and then counting these rearrangements. The second question can be answered by first selecting any two letters from the word “EXPAND” and then arranging them in different possible ways. More precisely, the second question can also be answered by actually writing down all the possible two-letter words using the letters in the word “EXPAND”. This gives us the following list: EX, XE, EP, PE, EA, AE, EN, NE, ED, DE, XP, PX, XA, AX, XN, NX, XD, DX, PA, AP, PN, NP, PD, DP, AN, NA, AD, DA, ND, DN. We find from this list that 30 different two-letter words can be made from the letters of the word “EXPAND”. We note that the words XA and AX are different even though they contain the same letters. This is so because the order of the letters in the word is important. Such rearrangements of objects in different orders are called their permutations.

A permutation is formally defined as follows.

Definition (Permutation): A permutation is an ordered arrangement of some or all objects in a given group of objects.

The number of distinct permutations of r distinct objects chosen from a given collection of n distinct objects is denoted by nPr , ${}^n P_r$, or $P(n,r)$.

6.3.1 Permutations when all objects are distinct:

Theorem 1. The number of permutations of n distinct objects taken r at a time, without repetitions, is $n \times (n - 1) \times (n - 2) \times \dots \times (n - r + 1)$.

Proof. The number of ways of arranging n distinct objects taken r at a time without repetitions is same as the number of ways r places can be filled using n objects.

For this, consider the following table.

Place	1 st	2 nd	3 rd	...	$r-2^{\text{nd}}$	$r-1^{\text{st}}$	r^{th}
Number of ways	n	$n-1$	$n-2$...	$[n-(r-3)]$	$[n-(r-2)]$	$[n-(r-1)]$

Table 6.1

The table shows that the first place can be filled with any of the n objects. As the result, there are n ways of filling the the first place. After putting one object in the first place, only $n-1$ objects are available because repetitions are not allowed. Therefore, the second place can be filled in $n-1$ ways. After putting two distinct objects in the first two places, only $n-2$ objects are available for the third place, so that the third place can filled in $n-2$ ways.

Continuing in this way, after putting $r-1$ objects in the first $r-1$ places, the number of available objects is $[n - (r-1)]$ for the r^{th} place. Hence, the r^{th} place can be filled in $[n - (r-1)]$ ways.

Now, using the multiplication principle of counting, the total number of ways of filling

r places using n distinct objects is given by the product:

$$n \times (n-1) \times (n-2) \times \dots \times ([n-(r-2)]) \times [n-(r-1)]$$

$$= n \times (n-1) \times (n-2) \times \dots \times (n-r+2) \times (n-r+1)$$

$$\text{Hence } {}^n P_r = n \times (n-1) \times (n-2) \times \dots \times (n-r+2) \times (n-r+1)$$

If we multiply and divide this product by $(n-r) \times (n-r-1) \times \dots \times 3 \times 2 \times 1$,

we find that

$${}^n P_r = n \times (n-1) \times \dots \times (n-r+1) \times \frac{(n-r) \times (n-r-1) \times \dots \times 3 \times 2 \times 1}{(n-r) \times (n-r-1) \times \dots \times 3 \times 2 \times 1}$$

$$= \frac{n \times (n-1) \times (n-2) \times \dots \times (n-r+1) \times (n-r) \times (n-r-1) \times \dots \times 3 \times 2 \times (n-r) \times (n-r-1) \times \dots \times 3 \times 2 \times 1}{(n-r) \times (n-r-1) \times \dots \times 3 \times 2 \times 1}$$

$$= \frac{n!}{(n-r)!}$$

We have thus found that

$${}^n P_r = \frac{n!}{(n-r)!}, \text{ for } r \leq n$$

The particular interesting case is when, all n objects are taken at a time. In this case, we obtain, by formula

$${}^n P_n = n \times (n-1) \times (n-2) \times \dots \times [n - (n-1)]$$

$$= n \times (n-1) \times (n-2) \times \dots \times 1$$

$$= n!$$

Alternatively, from the above formula, we obtain

$${}^n P_n = \frac{n!}{(n-n)!}$$

$$= \frac{n!}{0!}$$

$$= n!, \text{ since } 0! = 1, \text{ by an earlier result.}$$

6.3.5 Properties of Permutations

- (i) ${}^n P_n = n!$
 (ii) ${}^n P_0 = 1$
 (iii) ${}^n P_1 = n$
 (iv) ${}^n P_r = {}^{n(n-1)} P_{(r-1)}$
 $= {}^{n(n-1)(n-2)} P_{(r-2)}$
 $= {}^{n(n-1)(n-2)(n-3)} P_{(r-3)} = \dots$
 (vi) $\frac{{}^n P_r}{{}^n P_{r-1}} = n - r + 1$

SOLVED EXAMPLES

Ex. 1 : Find the value of ${}^4 P_2$ and interpret the answer.

Solution: ${}^4 P_2 = \frac{4!}{(4-2)!} = \frac{4!}{2!} = \frac{4 \times 3 \times 2!}{2!}$
 $= 4 \times 3 = 12.$

Interpretation four different objects can be arranged linearly in 12 ways when taken 2 at a time. Suppose P_1, P_2, P_3, P_4 are the four objects. The permutations of the four objects, taken two at a time are given by $(P_1, P_2), (P_1, P_3), (P_1, P_4), (P_2, P_1), (P_2, P_3), (P_2, P_4), (P_3, P_1), (P_3, P_2), (P_3, P_4), (P_4, P_1), (P_4, P_2), (P_4, P_3).$

Ex. 2 : How many different ways are there to arrange letters of the word “WORLD”? How many of these arrangements begin with the letter R? How many arrangements can be made taking three letters at a time?

Solution: The word WORLD has 5 letters W, O, R, L, D. These can be arranged among themselves in ${}^5 P_5 = 5! = 120$ different ways.

If an arrangement begins with R, the remaining four letters can be arranged in

${}^4 P_4 = 4! = 24$ ways.

The number of arrangements of 5 letters, taken three at a time, is ${}^5 P_3 = \frac{5!}{2!} = 60$

Ex. 3 : How many two digit numbers can be formed from the digits 2,4,5,6,7 if no digit is repeated?

Solution: Every arrangement of digits gives a different number. Therefore, the problem is to find the number of arrangements of five digits taken two at a time. This is given by ${}^5 P_2 = \frac{5!}{3!} = 20$

Alternatively, a two digit number has one digit in the unit's place and one digit in the ten's place.

The ten's place can be filled with any of the five given digits in five different ways.

Since a digit cannot be repeated, the unit's place can be filled using any of the remaining four digits in four different ways.

The multiplication principle then gives the required number as $5 \times 4 = 20$

Ex. 4 : How many numbers can be formed with the digits 3,4,6,7,8 taken all at a time? Find the sum of all such numbers.

Solution: The five digits can be arranged in ${}^5 P_5 = 5! = 120$ ways.

Now, consider any one of the five given digits, say 3. suppose the digit 3 is in the unit's place. The other four digits can be arranged in ${}^4 P_4 = 4! = 24$ ways to form numbers that have 3 in the unit's place. This shows that 24 of the 120 numbers have 3 in the unit's place.

Similarly, each of the other four digits is in the unit's place in 24 of the 120 numbers.

The sum of the digits in the units place among all 120 numbers is $24(3+4+6+7+8) = 24 \times 28 = 672$.

Similarly, the sum of the digits in the ten's place among all 120 numbers is 672. The same is also the sum of the digits in each place among all 120 numbers.

The required sum is then given by $672(1+10+100+1000+10000)$
 $= 672 \times 11111 = 74,66,592$

Ex. 5 : A teacher has 2 different books on English, 3 different books on physics, and 4 different books on Mathematics. These books are to be placed in a shelf so that all books on any one subjects are together. How many different ways are there to do this?

Solution: First, let us consider all books on each subjects to be one book, so that there are three books, say E,P,M. These three can be arranged in ${}^3P_3 = 3! = 6$ different ways. Now, in each of these ways, the 2 books on English can be arranged in ${}^2P_2 = 2! = 2$ different ways the 3 books on physics can be arranged in ${}^3P_3 = 3! = 6$ different ways, and the four books on Mathematics can be arranged in ${}^4P_4 = 4! = 24$ different ways.

The required number of arrangements is then given by $6 \times 2 \times 6 \times 24 = 1728$

Ex. 6 : Find n if ${}^nP_5 = 42 \times {}^nP_3$

Solution: We are given that ${}^nP_5 = 42 \times {}^nP_3$

That is, $\frac{n!}{(n-5)!} = 42 \frac{n!}{(n-3)!}$

$\therefore \frac{n!}{(n-5)!} = 42 \frac{n!}{(n-3)(n-4)(n-5)!}$

$\therefore (n-3)(n-4) = 42$

$\therefore n^2 - 7n - 30 = 0$

$\therefore (n-10)(n+3) = 0$

$\therefore n = 10 \text{ or } n = -3$

Since n cannot be negative, $n=10$

6.3.2 Permutations when repetitions are allowed:

We now consider problems of arranging n distinct objects taken r at a time when repetitions are allowed.

Theorem 2. The number of permutations of n distinct objects taken r at a time, when repetitions are allowed, is same as the number of ways of filling r places using n distinct objects when repetitions are allowed. Consider the following table.

Place	1 st	2 nd	3 rd	...	(r-2) th	(r-1) th	r th
Number of ways	n	n	n	...	n	n	n

Table 6.2

The first place can be filled in n ways because it can be filled with any of the n distinct objects. After putting one object in the first place, the number of distinct objects available for filling the second place is still n because repetitions are allowed. Therefore, the second place can also be filled in n ways. Similarly, after putting two objects in the first two places, the third place can be filled in n ways since repetitions are allowed and hence all the n distinct objects are still available. Continuing in this way, we notice that every place up to the rth can be filled in n ways because repetitions are allowed.

As the result of the above argument, it can be concluded that the number of permutations of n distinct objects taken r at a time, when repetitions are allowed, is given by

$n \times n \times \dots \times n \text{ (r times)} = n^r$

Remarks:

1. The number of permutations of n distinct objects taken all at a time, when m specified objects always come together, is $m! \times (n-m+1)!$.
2. The number of permutations of n distinct objects, taken all at a time, when m specified objects are never together is $(n-m)(n-m+1)!$
3. The number of permutations of n distinct objects taken r at a time, when a specified object is always to be included, in each arrangement is.

$$r \times {}^{(n-1)}P_{(r-1)}$$

4. The number of permutations of n distinct objects taken r at a time, when a specified object is not be included in any permutation, is ${}^{(n-1)}P_r$

SOLVED EXAMPLES

Ex. 1 : It is required to arrange 8 books on a shelf. Find the number of ways to do this if two specified books are

- (i) always together
- (ii) never together.

Solution :

- (i) The number of ways in which two specified books are always together is $2 \times (8-1)! = 2 \times 7! = 10080$
- (ii) The number of ways in which two specified books are never together is $(8-2)(8-1)! = 6 \times 7! = 30240$

Ex. 2 : In how many ways can 7 examination papers be arranged so that papers 6 and 7 are never together?

Solution : The number of ways in which any two papers are never together is.

$$(7-2)(7-1)! = 5 \times 6! = 3600$$

Ex. 3 : A family of 3 brothers and 5 sisters is to be arranged for a photograph in such a way that.

- (i) all brothers sit together.
- (ii) no two brothers sit together.

Solution :

- (i) Since all 3 brothers are together, treat them as one person, so that there are $5+1=6$ persons. the number of arranging them is

$${}^6P_6 = 6! = 720.$$

Once this is done, the three brothers can be arranged among themselves in ${}^3P_3 = 3! = 6$ ways.

The Total number of arrangements is then given by $6! \times 3! = 4320$.

- (ii) 5 Sister can be arranged among themselves in ${}^5P_5 = 5! = 120$ ways. consider the following arrangement.

$$* S_1 * S_2 * S_3 * S_4 * S_5 *$$

Where * indicates a position where one brother can be placed so that no two brothers are together. Since there are 6 positions and 3 brothers, the numbers of arrangements is

$${}^6P_3 = \frac{6!}{3!} = 120$$

The required number of arrangements is then given by

$${}^5P_5 \times {}^6P_3 = 120 \times 120 = 14400.$$

It is possible that some of the n objects are always kept together in a permutation problem. The following theorem is useful for such cases.

EXERCISE 6.3

- Find n if ${}^n P_6 : {}^n P_3 = 120:1$
- Find m and n if $({}^{m+n} P_2 = 56$ and $(m-n) P_2 = 12$
- Find r if ${}^{12} P_{r-2} : {}^{11} P_{r-1} = 3:14$
- Show that $(n+1) {}^n P_r = (n-r+1) ({}^{n+1} P_r$
- How many 4 letter words can be formed using letters in the word MADHURI if (i) letters can be repeated? (ii) letters cannot be repeated?
- Determine the number of arrangements of letters of the word ALGORITHM if.
 - vowels are always together.
 - no two vowels are together.
 - consonants are at even positions.
 - O is first and T is last.
- In a group photograph, 6 teachers are in the first row and 18 students are in the second row. There are 12 boys and 6 girls among the students. If the middle position is reserved for the principal and if no two girls are together, find the number of arrangements.
- Find the number of ways letters of the word HISTORY can be arranged if
 - Y and T are together
 - Y is next to T.
- Find the number of arrangements of the letters in the word BERMUDA so that consonents and vowels are in the same relative positions.
- Find the number of 4–digit numbers that can be formed using the digits 1,2,4,5,6,8 if
 - digits can be repeated
 - digits cannot be repeated
- How many numbers can be formed using the digits 0,1,2,3,4,5 without repetition so that resulting numbers are between 100 and 1000?
- Find the number of 6–digit numbers using the digits 3,4,5,6,7,8 without repetition. How many of these numbers are
 - divisible by 5?
 - not divisible by 5?
- A code word is formed by two distinct English letters followed by two non–zero distinct digits. Find the number of such code words. Also, find the number of such code words that end with an even digit.
- Find the number of ways in which 5 letters can be posted in 3 post boxes if any number of letters can be posted in a post box.
- Find the number of arranging 11 distinct objects taken 4 at a time so that a specified object.
 - always occurs
 - never occurs.

6.3.3 Permutations when all objects are not distinct

Consider the problem of rearranging letters in the words like GOOD, INDIA, GEOLOGY, MATHEMATICS, or PHILOSOPHY, where some letter occur more than once and hence all letters are not distinct.

Can we solve this problem? If we think so, how can we claim that we have obtained the right answer? The following result can provide us with a justification to our claim.

Theorem. Consider a collection of n objects, not all distinct, where n_1 objects are of one type and the remaining $n-n_1$ are distinct. The number of permutations of these n objects taken all at a time is $\frac{n!}{n_1!}$ provided $n_1 \leq n$.

Remarks.

1. The number of permutations of n objects, not all distinct, where n_1 objects are of one type and n_2 objects are of a second type, taken all at a time is

$$\frac{n!}{n_1!n_2!} \text{ provided } n_1 + n_2 \leq n.$$

2. The number of permutations of n objects, not all distinct, where n_i objects are of type i , $i=1, 2, \dots, k$, taken all at a time is $\frac{n!}{n_1!n_2!\dots n_k!}$ provided $n_1 + n_2 + \dots + n_k \leq n$.

SOLVED EXAMPLES

Ex. 1 : Find the number of distinct words that can be formed from the letters of the word "COMMON".

Solution : The given word "COMMON" has six letters, but two letters, namely "O" and "M" are repeated twice each. Therefore, the required number is

$$\frac{6!}{2!2!} = 180$$

Ex. 2 : A coin is tossed eight times. In how many ways can we obtain

- (a) 5 heads and 3 tails?
- (b) at least 6 heads?
- (c) at most 3 tails?

Solution : (a) $\frac{8!}{5!3!}$

$$(b) \frac{8!}{6!2!} + \frac{8!}{7!} + \frac{8!}{8!}$$
$$= 28 + 8 + 1 = 37$$

$$(c) \frac{8!}{8!} + \frac{8!}{7!} + \frac{8!}{2!6!} + \frac{8!}{3!5!}$$
$$= 1 + 8 + 28 + 56 = 93$$

Ex. 3 : How many distinct 8 digit numbers can be formed from digits in the number 62270208?

Solution : The given number has 8 digits. The digit 0 occurs twice and 2 occurs three times in this number. Therefore, the required number is

$$\frac{8!}{2!3!} = 3360$$

EXERCISE 6.4

1. Find the number of permutations of letters in each of the following words.
 - (i) DIVYA
 - (ii) SHANTARAM
 - (iii) REPRESENT
 - (iv) COMBINE
2. You have 2 identical books on English, 3 identical books on Hindi, and 4 identical books on Mathematics. Find the number of distinct ways of arranging them on a shelf.
3. A coin is tossed 8 times. In how many ways can we obtain. (i) 4 heads and 4 tails? (ii) at least 6 heads?
4. A bag has 5 red, 4 blue, and 4 green marbles. If all are drawn one by one and their colours are recorded, how many different arrangements can be found?
5. Find the number of ways of arranging letters of the word MATHEMATICAL. How many of these arrangements have all vowels together?
6. Find the number of different arrangements of letters in the word MAHARASHTRA. How many of these arrangements have (a) letters M and T never together? (b) all vowels together?
7. How many different words are formed if the letters R is used thrice and letters S and T are used twice each?

8. Find the number of arrangements of letters in the word MUMBAI so that the letter B is always next to A.
9. Find the number of arrangements of letters in the word CONSTITUTION that begin and end with N.
10. Find the number of different ways of arranging letters in the word ARRANGE. How many of these arrangements the two R's and two A's are not together?
11. How many distinct 5 digit numbers can be formed using the digits 3,2,3,2,4,5
12. Find the number of distinct numbers formed using the digits 3,4,5,6,7,8,9, so that odd positions are occupied by odd digits.
13. How many different 6–digit numbers can be formed using digits in the number 659942? How many of them are divisible by 2?
14. Find the number of distinct words formed from letters in the word INDIAN. How many of them have the two N's together?
15. Find the number of different ways of arranging letters in the word PLATOON if. (i) the two O's are never together. (ii) consonants and vowels occupy alternate positions.

6.3.4 Circular Permutations:

The arrangements of objects considered so far have been on a straight line. Sometimes arrangements are to be made around a circle, as would be required for a round table dinner or a round table meeting. Consider the following problem. Ramesh, Suresh, and Dinesh are to be seated for dinner at a round table. How many different ways can they be seated? Is this number the same as the number of ways they can be seated if they are to be seated in a row?

Before attempting to answer these questions, consider the following arrangements.

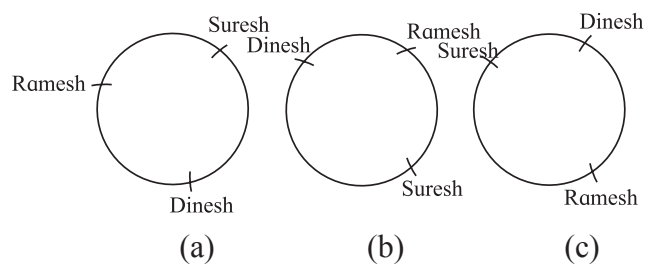

Fig. 6.5

Can we claim that the seating arrangements in Fig. 6.5 (b) and Fig. 6.5 (c) are different from the seating arrangement in Fig. 6.5 (a)? How can we justify our answer?

We may find that our answer to the question is negative. That is, the seating arrangements in Fig. 6.5(b) and Fig. 6.5(c) are not different from the seating arrangement in Fig. 6.5(a). This is justified by the fact that the relative positions of the three friends are the same in all the three seating arrangements. The only difference between the three seating arrangements is that the seats of the three friends have been rotated (either clockwise or anticlockwise) to obtain one arrangement from another.

If we want to have different relative positions of the three friends, we must consider the following two seating arrangements.

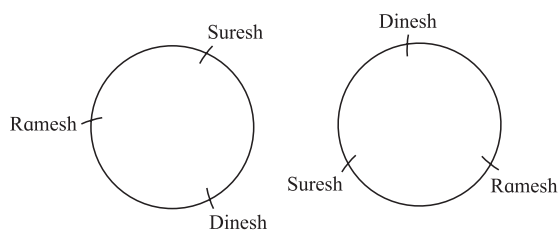

Fig. 6.6

In general, if n distinct objects are to be arranged around a circle, then n different linear arrangements coincide with a single circular arrangement. Since there are $n!$ different linear arrangements of n distinct objects taken all at a time, the number of circular arrangements of n distinct objects taken all at a time is given by

$$\frac{n!}{n} = (n-1)!$$

Remarks:

1. It may be easy to understand the above formula if we arrange the n distinct objects as follows. A circular arrangement does not have a fixed starting point, and hence rotations of any one arrangement appear to be the same. In order to fix the starting point, fix the position of one of the n distinct objects, and then arrange the remaining $n-1$ distinct objects. Now, we have the problem of arranging $n-1$ distinct objects taken all at a time, the number of such arrangements is $(n-1)!$
2. If clockwise and anticlockwise arrangements that are mirror images of each other are not to be considered different, then the number of circular arrangements of n distinct objects

is $\frac{(n-1)!}{2}$

Now consider the situation where m of the n objects are alike and cannot be distinguished from one another. The following result gives the formula for the number of circular arrangements of these n objects.

Theorem. The number of circular arrangements of n objects, of which m objects are alike (indistinguishable), is given by $\frac{(n-1)!}{m!}$

Does this argument remind us a similar argument that we came across earlier?

Remark: The number of circular permutations of n distinct objects taken r at a time can be found under two different conditions as follows.

- (a) When clockwise and anticlockwise arrangements are considered to be different, then the required number of circular arrangements is given by $\frac{{}^n P_r}{r}$
- (b) When clockwise and anticlockwise arrangements are not to be considered different, then the required number of circular arrangements is given by $\frac{{}^n P_r}{2r}$

We may try to verify these two statements.

SOLVED EXAMPLES

Ex. 1 : In how many ways can 8 students be seated at a round table so that two particular students are together if students are seated with respect to each other?

Solution : Treat the two particular students as a single student, so we have 7 students.

students are seated with respect to each other means one student is seated first and other students are seated in positions relative to him. Since there are 6 students to be seated with respect to the first student, there are $6!$ ways of seating them. The two students who are together can be seated in $2! = 2$ distinct ways. Therefore, the required number is

$$6! \times 2! = 1440$$

Ex. 2 : Find the number of distinct ways of seating 6 men and 6 women around a table when

- (a) there is no restriction
- (b) no two women are seated next to each other.

Solution (a) : When there is no restriction, there are 12 persons to be seated around a table. The number of possible arrangements is $(12 - 1)! = 11!$

- (b) The six men can be seated around a table in $(6 - 1)! = 5!$ ways. Since no two women sit next to each other, a woman must be seated between two men. There are 6 spaces between men and there are six women. Therefore, the required number is $(5!) (6!) = 86400$.

6. Five men, two women, and a child sit around a table. Find the number of arrangements where the child is seated (i) between the two women. (ii) between two men.
7. Eight men and six women sit around a table. How many of sitting arrangements will have no two women together?
8. Find the number of seating arrangements for 3 men and 3 women to sit around a table so that exactly two women are together.
9. Four objects in a set of ten objects are alike. Find the number of ways of arranging them in a circular order.
10. Fifteen persons sit around a table. Find the number of arrangements that have two specified persons not sitting side by side.

EXERCISE 6.5

1. In how many different ways can 8 friends sit around a table?
2. A party has 20 participants and a host. Find the number of distinct ways for the host to sit with them around a circular table. How many of these ways have two specified persons on either side of the host?
3. Delegates from 24 countries participate in a round table discussion. Find the number of seating arrangements where two specified delegates are. (i) always together, (ii) never together.
4. Find the number of ways for 15 people to sit around the table so that no two arrangements have the same neighbours.
5. A committee of 20 members sits around a table. Find the number of arrangements that have the president and the vice president together.

6.4 Combinations

We may have noticed that permutations involve ordered arrangements of objects. We shall now consider situations where the order of objects in an arrangement is not important, but only selection of objects in the arrangement is important. A selection of objects without any consideration for the order is called a combination.

Let us consider the following example. A group of 5 students, denoted by S_1, S_2, S_3, S_4, S_5 , is available for selection and a team of two of these students is to be selected for a doubles game. In how many ways can the team be selected?

Let us write down all the possible team selections, so that we can count them. Do we get the following teams?

S_1 and S_2 , S_1 and S_3 , S_1 and S_4 , S_1 and S_5 , S_2 and S_3 , S_2 and S_4 , S_2 and S_5 , S_3 and S_4 , S_3 and S_5 , S_4 and S_5 . Is " S_2 and S_1 " a different selection from " S_1 and S_2 "? Does the order of selection play any role here?

When we consider a team of two players, the team " S_1 and S_2 " is same as the team " S_2 and S_1 ". This is so because only selection of two players

S_1 and S_2 is enough to form the team. The order in which the two players are selected is immaterial. In other words, the order of selection does not play any role in this situation. We may notice that “ S_1 and S_2 ” and “ S_2 and S_1 ” are two different permutations, but the same selection. The same conclusion can be drawn about all other pairs listed above. Such selections, where the order of selection is immaterial, are called combinations. Let us now have the formal definition of a combination.

Definition: Combination. A combination of a set of n distinct objects taken r at a time without repetition is an r -element subset of the n objects.

Note: The arrangement of the elements does not matter in a combination.

The number of combinations of n distinct objects taken r at a time without repetition is denoted by ${}^n C_r$, ${}^n C_r$, or $C(n,r)$.

Let us go back to the example of selecting a team of 2 students from the group of 5. This time, however, we want to select a team of 3 students. Can we make a list of all possible selections? Let us try and confirm that these selections are as follows.

S_1, S_2 and S_3 ; S_1, S_2 and S_4 ; S_1, S_2 and S_5 ; S_1, S_3 and S_4 ; S_1, S_3 and S_5 ; S_1, S_4 and S_5 ; S_2, S_3 and S_4 ; S_2, S_3 and S_5 ; S_2, S_4 and S_5 ; S_3, S_4 and S_5 .

What is interesting to note is the number of possible teams in both the examples is 10. In other words, what we have found is that ${}^5 C_2 = {}^5 C_3 = 10$. Can we explain why this happens?

Let us consider selection of a team of 3 students from the group of 5. When we select 3 students, we leave 2 students out of the team. Therefore, selecting a team of 3 students from the group of 5 is same as selecting 2 students (to left out of the team) from the group of 5.

The question that may arise now is: “Is such a relation true in general?” This question can be answered when we learn the mathematical formula for the number of combinations of n distinct

objects taken r at a time without repetition. The following theorem gives this formula.

Theorem. The number of combinations of n distinct objects taken r at a time without repetitions is given by ${}^n C_r = \frac{n!}{r!(n-r)!}$

The relation between ${}^n P_r$ and ${}^n C_r$ is ${}^n C_r \times r! = {}^n P_r$

6.4.1 Properties of combinations.

$$\begin{aligned} 1. \quad {}^n C_{n-r} &= \frac{n!}{(n-r)![n-(n-r)]!} \\ &= \frac{n!}{(n-r)!r!} \\ &= \frac{n!}{(n-r)!r!} \\ &= {}^n C_r \end{aligned}$$

$$\therefore {}^n C_r = {}^n C_{n-r} \quad \text{for } 0 \leq r \leq n$$

$$2. \quad {}^n C_0 = \frac{n!}{0!(n-0)!} = \frac{n!}{n!} = 1, \text{ because } 0! = 1$$

as stated earlier.

$$3. \quad \text{If } {}^n C_r = {}^n C_s, \text{ then either } s = r \text{ or } s = n-r.$$

$$4. \quad {}^n C_r = \frac{nPr}{r!}$$

$$5. \quad {}^n C_r + {}^n C_{r-1} = {}^{n+1} C_r$$

$$6. \quad {}^n C_0 + {}^n C_1 + \dots + {}^n C_n = 2^n$$

$$\begin{aligned} 7. \quad {}^n C_0 + {}^n C_2 + {}^n C_4 + \dots \\ = {}^n C_1 + {}^n C_3 + {}^n C_5 + \dots = 2^{(n-1)} \end{aligned}$$

$$\begin{aligned} 8. \quad {}^n C_r &= \frac{n}{r} {}^{n-1} C_{r-1} \\ &= \frac{n}{r} \frac{n-1}{r-1} {}^{n-2} C_{r-2} = \dots \end{aligned}$$

SOLVED EXAMPLES

Ex.1 : Find the values of

(i) 7C_3 (ii) ${}^{10}C_7$ (iii) ${}^{52}C_3$

Solution : We know that

$${}^nC_r = \frac{n!}{r!(n-r)!}$$

$$\begin{aligned} \text{(i)} \quad {}^7C_3 &= \frac{7!}{3!(7-3)!} \\ &= \frac{7!}{3!4!} \end{aligned}$$

$$= \frac{7 \times 6 \times 5 \times 4!}{3 \times 2 \times 1 \times 4!}$$

$$= \frac{7 \times 6 \times 5}{3 \times 2 \times 1} = 35$$

$$\text{(ii)} \quad {}^{10}C_7 = \frac{10!}{7!(10-7)!}$$

$$= \frac{10!}{7!3!}$$

$$= \frac{10 \times 9 \times 8}{3 \times 2}$$

$$= 120$$

$$\text{(iii)} \quad {}^{52}C_3 = \frac{52!}{3!(52-3)!}$$

$$= \frac{52!}{3!49!}$$

$$= \frac{52 \times 51 \times 50}{3 \times 2 \times 1} = 22100$$

Ex.2 : Find n and r , if

$${}^nC_{r-1} : {}^nC_{r+1} = 14 : 8 : 3$$

Solution : We know that

$$\therefore {}^nC_{r-1} = \frac{n!}{(r-1)!(n-r+1)!}$$

$$\therefore {}^nC_r = \frac{n!}{r!(n-r)!}$$

$${}^nC_{r+1} = \frac{n!}{(r+1)!(n-r-1)!}$$

$$\frac{{}^nC_{r-1}}{{}^nC_r} = \frac{r}{(n-r+1)} \text{ and } \frac{{}^nC_r}{{}^nC_{r+1}} = \frac{r+1}{n-r}$$

$$\frac{{}^nC_{r-1}}{{}^nC_r} = \frac{14}{8} = \frac{7}{4} \text{ and } \frac{{}^nC_r}{{}^nC_{r+1}} = \frac{8}{3}$$

$$\therefore \frac{r}{n-r+1} = \frac{7}{4} \text{ and } \frac{r+1}{n-r} = \frac{8}{3}$$

$$\therefore (n-r) = \frac{4}{7} (r-1)$$

$$\therefore (n-r) = \frac{8}{3} (r+1)$$

$$\therefore \frac{4}{7} (r-1) = \frac{8}{3} (r+1)$$

Solving this, we get $r = 7$ and $n = 10$.

Ex.3 : A plane consists of n points. Find the number of straight lines and triangles that can be obtained by joining points in a plane, if

(i) no three points are collinear.

(ii) p points are collinear ($p \geq 3$).

Solution :

(i) Straight line can be drawn by joining any two points and triangle can be drawn by joining any three non-collinear points.

From n points, any two points can be selected in nC_2 ways.

\therefore Number of straight lines = nC_2

Since no three points are collinear, any three points can be selected in nC_3 ways.

\therefore Number of triangles = nC_3

- (ii) If we are given that p -point are non-collinear, we can obtain pC_2 straight lines and pC_3 triangles. But we are given that p -points are collinear, therefore they form only one line and no triangle i.e. we have counted ${}^pC_2 - 1$ extra lines and pC_3 extra triangles.

If p -points ($p \geq 3$) are collinear, then number of straight lines = ${}^n C_2 - ({}^p C_2 - 1)$ and number of triangles = ${}^n C_3 - {}^p C_3$

Ex.4 : Four cards are drawn from a pack of 52 playing cards. In how many different ways can this is done? How many selections will contain

- (i) exactly one card of each suit ?
- (ii) all cards of the same suit ?
- (iii) all club cards ?
- (iv) at least one club card ?
- (v) three kings and one queen ?
- (vi) three black and one red card?

Solution :

- (i) A pack of 52 cards contains 4 different suits. viz. club, spade, diamond and heart. Each suit contains 13 cards. Club and spade are black coloured cards. Diamond and heart are red coloured cards i.e. pack of 52 card contains 26 black and 26 red colour cards.

From a pack of 52 cards any 4 cards can be

drawn in ${}^{52}C_4 = \frac{52!}{4! \times 48!}$ ways.

- (i) Exactly one card of each suit.

One club card can be selected in ${}^{13}C_1 = 13$ ways. One spade card can be selected in ${}^{13}C_1 = 13$ ways. One diamond card can be

selected in ${}^{13}C_1 = 13$ ways. One heart card can be selected in ${}^{13}C_1 = 13$ ways.

\therefore Using fundamental principal, exactly one card of each suit can be selected in $13 \times 13 \times 13 \times 13 = (13)^4$ ways.

- (ii) All cards are of the same suit.

From 4 suits, any one suit can be selected in ${}^4C_1 = 4$ ways. After this is one done, any four cards from selected suit can be drawn in ${}^{13}C_4 = 715$ ways.

\therefore Using fundamental principal, all 4 cards of the same suit can be drawn in $4 \times {}^{13}C_4 = 2860$ ways.

- (iii) All club cards

From 13 club cards, any 4 club cards can be drawn in ${}^{13}C_4 = 715$ ways.

- (iv) At least one club.

From a pack of 52 cards, any 4 cards can be drawn in ${}^{52}C_4 = \frac{52!}{4! \times 48!}$ ways if there is no condition.

From ${}^{52}C_4$ selections remove those selections that do not contain any club card, so that in the remaining selections we have at least one club card i.e. 4 cards are drawn from remaining 39 non-club cards and this can be done in ${}^{39}C_4$ ways.

\therefore Number of selections which contain at least one club card = ${}^{52}C_4 - {}^{39}C_4$

- (v) Three king cards and one queen card.

From 4 kings, any 3 king cards can be selected in ${}^4C_3 = 4$ ways and from 4 queen cards 1 queen card can be selected in ${}^4C_1 = 4$ ways.

\therefore Using fundamental principle, three king cards and one queen card can be selected in $4 \times 4 = 16$ ways.

(vi) Three black cards and one red card.

From 26 black cards, any 3 black cards can be selected in ${}^{26}C_3$ ways and from 26 red cards, any one red card can be selected in ${}^{26}C_1$ ways.

\therefore Using fundamental principle, three black and one red card can be selected in ${}^{26}C_3 \times {}^{26}C_1$ ways.

Ex.5 : Find n , if ${}^nC_8 = {}^nC_6$

Solution : If ${}^nC_x = {}^nC_y$

then either $x = y$ or $x = n - y$

$$\therefore 8 = n - 6 \quad \therefore n = 14$$

Find r ,

$$\text{If } {}^{16}C_4 + {}^{16}C_5 + {}^{17}C_6 + {}^{18}C_7 = {}^{19}C_r$$

Solution :

$$({}^{16}C_4 + {}^{16}C_5) + {}^{17}C_6 + {}^{18}C_7 = {}^{19}C_r$$

$$\therefore ({}^{17}C_5 + {}^{17}C_6) + {}^{18}C_7 = {}^{19}C_r$$

$$\therefore ({}^{18}C_6 + {}^{18}C_7) = {}^{19}C_r$$

$$\therefore {}^{19}C_7 = {}^{19}C_r$$

$$\therefore r = 7 \text{ or } r = 19 - 7 = 12$$

Ex.6 : Find the difference between the maximum values of 8C_r and ${}^{11}C_r$

Solution : Maximum values of 8C_r occurs at

$$r = \frac{8}{2} = 4$$

$$\therefore \text{maximum values of } {}^8C_r = {}^8C_4 = 70$$

Maximum values of ${}^{11}C_r$ occurs at

$$r = \frac{10}{2} = 5 \quad \text{or at } \frac{12}{2} = 6$$

$$\therefore \text{Maximum values of } {}^{11}C_r = {}^{11}C_5 = {}^{11}C_6 = 462$$

$$\therefore \text{difference between the maximum values of } {}^8C_r \text{ and } {}^{11}C_r = {}^8C_4 - {}^{11}C_5 = 70 - 462 = -392$$

$$\text{OR } {}^{11}C_5 - {}^8C_4 = 462 - 70 = 392$$

EXERCISE 6.6

1. Find the value of (i) ${}^{15}C_4$ (ii) ${}^{80}C_2$
(iii) ${}^{15}C_4 + {}^{15}C_5$ (iv) ${}^{20}C_{16} - {}^{19}C_{16}$
2. Find n if
(i) ${}^6P_2 = n {}^6C_2$
(ii) ${}^{2n}C_3 : {}^nC_2 = 52 : 3$
(iii) ${}^nC_{n-3} = 84$
3. Find r if ${}^{14}C_{2r} : {}^{10}C_{2r-4} = 143:10$
4. Find n and r if.
(i) ${}^nP_r = 720$ and ${}^nC_{n-r} = 120$
(ii) ${}^nC_{r-1} : {}^nC_r : {}^nC_{r+1} = 20: 35:42$
5. If ${}^nP_r = 1814400$ and ${}^nC_r = 45$, find r
6. If ${}^nC_{r-1} = 6435$, ${}^nC_r = 5005$, ${}^nC_{r+1} = 3003$
find rC_5 .
7. Find the number of ways of drawing 9 balls from a bag that has 6 red balls, 5 green ablls, and 7 blue balls so that 3 balls of every colour are drawn.
8. Find the number of ways of selecting a team of 3 boys and 2 girls from 6 boys and 4 girls.
9. After a meeting, every participant shakes hands with every other participants. If the number of handshakes is 66, find the number of participants in the meeting.

10. If 20 points are marked on a circle, how many chords can be drawn?
 11. Find the number of diagonals of an n -sided polygon. In particular, find the number of diagonals when.
 - (a) $n = 10$ (b) $n = 15$
 - (c) $n = 12$
 12. There are 20 straight line in a plane so that no two lines are parallel and no three lines are concurrent. Determine the number of points of intersection.
 13. Ten points are plotted on a plane. Find the number of straight lines obtained by joining these points if
 - (i) no three points are collinear.
 - (ii) four points are collinear.
 14. Find the number of triangles formed by joining 12 points if
 - (i) no three points are collinear
 - (ii) four points are collinear.
 15. A word has 8 consonants and 3 vowels. How many distinct words can be formed if 4 consonants and 2 vowels are chosen?
9. Find the differences between the largest values in the following:
 - (i) ${}^{14}C_r - {}^{12}C_r$, (ii) ${}^{13}C_r - {}^8C_r$, (iii) ${}^{15}C_r - {}^{11}C_r$,
 10. In how many ways can a boy invite his 5 friends to a party so that at least three join the party?
 11. A group consists of 9 men and 6 women. A team of 6 is to be selected. How many of possible selections will have at least 3 women?
 12. A committee of 10 persons is to be formed from a group of 10 women and 8 men. How many possible committees will have at least 5 women? How many possible committee will have men in majority?
 13. A question paper has two sections. section I has 5 questions and section II has 6 questions. A student must answer at least two question from each section among 6 questions he answers. How many different choices does the student have in choosing questions?
 14. There are 3 wicketkeepers and 5 bowlers among 22 cricket players. A team of 11 players is to be selected so that there is exactly one wicketkeeper and at least 4 bowlers in the team. How many different teams can be formed?
 15. Five students are selected from 11. How many ways can these students be selected if.
 - (a) two specified students are selected?
 - (b) two specified students are not selected?

EXERCISE 6.7

1. Find n if ${}^nC_8 = {}^nC_{12}$
2. Find n if ${}^{23}C_{3n} = {}^{23}C_{2n+3}$
3. Find n if ${}^{21}C_{6n} = {}^{21}C_{n+5}^2$
4. Find n if ${}^{2n}C_{r-1} = {}^{2n}C_{r+1}$
5. Find n if ${}^nC_{n-2} = 15$
6. Find x if ${}^nP_r = x \cdot {}^nC_r$
7. Find r if ${}^{11}C_4 + {}^{11}C_5 + {}^{12}C_6 + {}^{13}C_7 = {}^{14}C_r$
8. Find the value of $\sum_{r=1}^4 {}^{21-r}C_4 + {}^{17}C_5$



Let's Remember

- **Addition principle** - If one event can occur in m ways and the second event with no common outcomes can occur out in n ways, then either of the two events can occur in $m+n$ ways.
- **Multiplication principle** - If one operation can be carried out in m ways, followed by the

second operation that can be carried out in n ways, then the two operations can be carried out in $m \times n$ ways.

- **Factorial Function** - For a natural number n , the factorial of n , written as $n!$ and read as "n factorial" is the product of natural numbers from 1 upon n .

That is, $n! = 1 \times 2 \times \dots \times (n-1) \times n$.

- **Permutations** - A permutation is an ordered arrangement of some or all objects in a given group of objects.

The number of distinct permutations of r distinct objects chosen from a given collection of n distinct objects is denoted by ${}^n P_r$, $n P_r$, or $P(n,r)$.

$${}^n P_r = \frac{n!}{(n-r)!} \text{ for } r \leq n.$$

- The number of permutations of n distinct objects taken all at a time when 2 specified objects always come together, is $2 \times (n-1)!$
- The number of permutations of n distinct object taken r at a time, when a specified object is always to be included, is $r \times (n-1)P_{r-1}$. The number of permutations of n distinct objects taken r at a time, when n object specified object is not be included in any permutation, is $(n-1)P_r$.
- **Permutations when all objects are not distinct**- The number of permutation of n objects, not all distinct, where n_i objects are of type i , $i=1, 2, \dots, k$, taken all at a time is provided $n_1 + n_2 + \dots + n_k \leq n$.

$$\frac{n!}{n_1! n_2! \dots n_k!} \text{ provided } n_1 + n_2 + \dots + n_k \leq n.$$

Circular Permutations -

- It may be easy to understand the above formula if we arrange the n distinct object as follows. A circular arrangement does not have a fixed starting point, and hence rotations of any one arrangement appear to be the same. In order

to fix the starting point, fix the position of one of the n distinct objects, and then arrange the remaining $n-1$ distinct objects. Now, we have the problem of arranging $n-1$ distinct objects taken all at a time the number of such arrangements is $(n-1)!$

- If clock wise and anticlockwise arrangement that are mirror image of each other are not to be considered different, then the number of circular arrangements of n distinct objects is

$$\frac{n!}{(n-r)!}$$

- The number of circular arrangement of a objects, of which m objects are alike

(indistinguishable, is given by $\frac{(n-1)!}{m!}$)

- When clock wise and anti clock wise arrangements are considered to be different, then the required number of circular

$$\text{arrangements is given by } \frac{{}^n P_r}{r}$$

- When clock wise and anti clock wise arrangements are not to be considered different, then the required number of circular

$$\text{arrangements is given by } \frac{{}^n P_r}{2r}$$

Properties of Permutations

- ${}^n P_r = n!$
- ${}^n P_0 = 1$
- ${}^n P = n$
- ${}^n P_r^i = n \cdot {}^{n-1} P_{r-1} = n(n-1) \dots (n-r+2) \dots (n-r)$
- $\frac{{}^n P_r}{{}^n P_{r-1}} = n - r + 1$
- **Combinations** - The arrangement of the elements does not matter in a combination. The number of combinations of n distinct objects taken r at a time without repetition is

denoted by nC_r , nCr , or $C(n,r)$.

- $${}^nC_r = \frac{n!}{r!(n-r)!}$$
- $${}^nC_r \times r! = {}^nP_r$$

Properties of combinations.

- Thus, ${}^nC_{n-r} = {}^nC_r$ for $0 \leq r \leq n$.
- $${}^nC_0 = \frac{n!}{0!(n-0)!} = \frac{n!}{n!} = 1$$
, Because $0! = 1$
as has been stated earlier.
- $${}^nC_n = \frac{n!}{n!(n-n)!} = \frac{n!}{n!0!} = 1$$
,
again because $0! = 1$
- If ${}^nC_r = {}^nC_s$, then either $s = r$ or $s = n - r$.
- $${}^nC_r = \frac{{}^nP_r}{r!}$$
- $${}^nC_r + {}^nC_{r-1} = {}^{n+1}C_r$$
- $${}^nC_0 + {}^nC_1 + \dots + {}^nC_n = 2^n$$
- $${}^nC_0 + {}^nC_2 + {}^nC_4 + \dots = {}^nC_1 + {}^nC_3 + {}^nC_5 + \dots = 2^{n-1}$$

MISCELLANEOUS EXERCISE - 6

- Find the value of r if ${}^{56}C_{r+2} : {}^{54}P_{r-1} = 30800:1$
- How many words can be formed by writing letters in the word CROWN in different order?
- Find the number of words that can be formed by using all the letters in the word REMAIN. If these words are written in dictionary order, what will be the 40th word?
- Find the number of ways of distributing n balls in n cells. What will be the number of ways if each cell must be occupied?
- Thane is the 20th station from C.S.T. If a passenger can purchase a ticket from any station to any other station, how many different tickets must be available at the booking window?
- English alphabet has 11 symmetric letters that appear same when looked at in a mirror. These letters are A, H, I, M, O, T, U, V, W, X, and Y. How many symmetric three letter password can be formed using these letters?
- How many numbers formed using the digits 3,2,0,4,3,2,3 exceed one million?
- Ten students are to be selected for a project from a class of 30 students. These are 4 students who want to be together either in the project or not in the project. Find the number of possible selections.
- A student finds 7 books of his interest, but can borrow only three books. He wants to borrow chemistry part II book only if Chemistry Part I can also be borrowed. Find the number of ways he can choose three books that he can borrow.
- 30 objects are to be divided in three groups containing 7,10,13 objects. Find the number of distinct ways for doing so.
- A student passes an examination if he/she secures a minimum in each of the 7 subjects. Find the number of ways a student can fail.
- Nine friends decide to go for a picnic in two groups. One group decides to go by car and the other group decides to go by train. Find the number of different ways of doing so if there must be at least 3 friends in each group.

13. Five balls are to be placed in three boxes, where each box can contain upto five balls. Find the number of ways if no box is to remain empty.
14. A hall has 12 lamps and every lamp can be switched on independently. Find the number of ways of illuminating the hall.
15. How many quadratic equations can be formed using numbers from 0,2,4,5 as coefficients if a coefficient can be repeated in an equation.
16. How many six–digit telephone numbers can be formed if the first two digits are 45 and no digit can appear more than once?
17. A question paper has 6 questions. How many ways does a student have if he wants to solve at least one question?
18. Find the number of ways of dividing 20 objects in three groups of sizes 8,7,and 5.
19. There are 8 doctors and 4 lawyers in a panel. Find the number of ways for selecting a team of 6 if at least one doctor must be in the team.
20. Four parallel lines intersect another set of five parallel lines. Find the number of distinct parallelograms that can be formed.

Activity 6.1

- (1) Bring your family photo

No. of members =

No of males =

No of females =

If they are to be stand in a line for a photograph

- (a) How many options are there?
- (b) If males are together & females are together how many arrangements are there?
- (c) If no two females are together then how many arrangement are there?

Activity 6.2

Note down your 10 digit mobile phone number.

- (a) How many different 2 digit numbers are possible?
- (b) How many 3 digits numbers with repetition are possible?
- (c) How many 4 digit even numbers without repetition are possible.

Activity 6.3

- 1) You have a party at your place. You go to shop. Find the no. of items and there

Flavours of cakes are available.

Flavours of cookies are available.

types of wafers are available.

types of cold drinks are available.

You have to select 1 type of cake, 2 types of cookies, 2 types of wafers and 1 type of cold drink.

Find the total number of combinations.

2) Make a number card on A4 size paper for each of the digits 1, 4, 5, 6, 8, 0, 7 and laminate them.

i) Take any 5 number cards and place them on table.

ii) See how many 2 digit numbers you can form without repetitions.

iii) See how many 3 digit numbers you can form without repetition.

iv) See how many 4 digit numbers you can form without repetition.

(Note : Construct the different problems from such number cards)



7. PROBABILITY



Let's Study

- Types of events
- Algebra of events
- Probability
- Addition theorem
- Conditional Probability

Introduction :

The dictionary meaning of Probability is “Chance”. The words such as chance, probably, likely, possibly are used in our life.

For example

- 1) It is likely to rain today.
- 2) Our school Hockey team has good chance to win intercollegiate tournament.
- 3) The chance that a new born child is a girl is 50%

In each of the above statements there is a different degree of certainty. The probability measures the degree of certainty of an event.

There are two types of experiments, namely deterministic experiment and probabilistic experiment.

A deterministic experiment is like finding the area of a given right angled triangle.

A probabilistic experiment is like throwing a die and trying to find a certain number on the top. We will study the probabilistic experiments.

In previous standards we have defined probability as “The ratio of number of favourable outcomes to the total number of all possible outcomes”.

For example, suppose the experiment is of forming a two-digit number using the digits

3,6,8,9 without repetition. What is the probability (chance) that an even number is formed?

The following set S (Sample space) shows different ways of forming a two-digit number.

$$S = \{36, 38, 39, 63, 68, 69, 83, 86, 89, 93, 96, 98\}$$

$$\therefore n(S) = 12$$

The favourable outcomes are even numbers.

The set of favourable outcomes is

$$A = \{36, 38, 68, 86, 96, 98\}$$

$$\therefore n(A) = 6$$

$$\therefore \text{Required probability is, } P(A) = \frac{n(A)}{n(S)} = \frac{6}{12} = \frac{1}{2}$$



Let's Recall

- 1) **Random experiment:** A random experiment is an action in which all the possible results are known in advance and are equally likely. The exact result is unpredictable i.e. not known in advance.

Example

- a) When a card is drawn from a well-shuffled pack of 52 cards, it is a random experiment because we know in advance that there are 52 equally possible results
- b) Selecting any two students from a group of 5 students to play a game of chess is a random experiment because (i) we know in advance that any two students can be selected from 5 students in ${}^5C_2 = 10$ different ways i.e. we have 10 different results, (ii) we don't know in advance which two students are going to be selected.

2) **Outcome:** The result of a random experiment is called “outcome of experiment”.

Examples

a) Suppose a random experiment is “die is thrown”. Then we may get number 1,2,3,4,5, or 6 on the upper face of die that is this experiment gives 6 possible results or outcomes.

b) Suppose a random experiment is “3 students are selected from a group of 5 students S_1, S_2, S_3, S_4 and S_5 ”. This can be done in ${}^5C_3 = 10$ different ways .

∴ This experiment has 10 different outcomes or results.

c) Suppose a random experiment is “3 books B_1, B_2, B_3 are to be arranged in a line on a shelf”.

This can be done in ${}^3P_3 = 3! = 6$ different ways.

∴ This experiment has 6 different outcomes or results.

3) **Equally likely outcomes:** The outcomes of random experiment are said to be equally likely, if none of them is expected to occur in preference to any other.

Examples

a) If an unbiased coin is tossed, we have no reason to expect that Head will appear more often than Tail or vice versa.

b) If a baby is born, it is equally likely that it is a boy or it is a girl.

4) **Sample space:** The set of all possible outcomes of a random experiment is called the sample space. It is denoted by S or Ω .

Each element of the sample space is called a sample point. The number of elements in the sample space is denoted by $n(S)$ or $n(\Omega)$.

Example

a) Suppose a random experiment is of tossing a coin 3 times. Then the sample space is

$$S = \{HHH, HHT, HTH, HTT, THH, THT, TTH, TTT\}$$

∴ $n(S) = 8$

b) Suppose a random experiment is of throwing a die. Then the sample space $S = \{1, 2, 3, 4, 5, 6\}$

∴ $n(S) = 6$

5) **Event:** A subset of the sample space is called an event.

Example

A random experiment consists of tossing a pair of dice.

Here, Sample space

$$S = \{(1,1), (1,2), (1,3), (1,4), (1,5), (1,6), (2,1), (2,2), (2,3), (2,4), (2,5), (2,6), (3,1), (3,2), (3,3), (3,4), (3,5), (3,6), (4,1), (4,2), (4,3), (4,4), (4,5), (4,6), (5,1), (5,2), (5,3), (5,4), (5,5), (5,6), (6,1), (6,2), (6,3), (6,4), (6,5), (6,6)\}$$

∴ $n(S) = 36$

Define a subset A of S as follows

$$A = \{(x,y) \mid x+y \text{ is a perfect square}\}$$

∴ $A = \{(1,3), (2,2), (3,1), (3,6), (4,5), (5,4), (6,3)\}$

∴ $n(A) = 7$

A contains 7 favourable outcomes out of 36 possible outcomes.

Subset A is an event defined on the sample space S.

Remark: A is a subset of S ∴ $0 \leq n(A) \leq n(S)$



7.1 TYPES OF EVENTS:

A) Simple or elementary event: A subset of sample space, consisting of a single element is called a simple or elementary event. Every sample point of the sample space S forms an elementary event.

Example

- a) If 2 coins are tossed, then the sample space is $S = \{HH, HT, TH, TT\}$

Let A be the event that both the coins show tails.

- $\therefore A = \{TT\}$. In this case event A contains only one sample point of the sample space S.

Therefore, event A is a simple or elementary event.

- b) If a die is thrown, then the sample space is $S = \{1, 2, 3, 4, 5, 6\}$

Let B be the event that die shows an even prime number

- $\therefore B = \{2\}$. In this case event B contains only one sample point of the sample space S. Therefore, event B is a simple or elementary event.

B) Occurrence and non-occurrence of event:

After conducting an experiment, if the outcome belongs to subset A then we say that event A has occurred. If the outcome does not belong to subset A then we say that event A has not occurred.

Example

If a die is thrown, then the sample space $S = \{1, 2, 3, 4, 5, 6\}$

Let event A be that the die shows a number which is a multiple of 3. $\therefore A = \{3, 6\}$

After conducting the experiment, if the die shows number 3 or 6, then we say that event A has occurred. If the die shows a number say 5, then we say that event A has not occurred.

- C) **Sure Event:** An event which contains all the sample points of the sample space S, is called as a sure event.

Example

A card is drawn at random from a pack of 52 cards. Let event A be that a card drawn is either red or black. \therefore Event A is a sure event.

- D) **Impossible Event:** An event which does not contain any sample point of the sample space S is called an impossible event. Null set ϕ represents an impossible event.

Example

A die is thrown.

- \therefore Sample Space $S = \{1, 2, 3, 4, 5, 6\}$
Let event B: die shows number 7.
 $\therefore B = \{\} = \phi$
 \therefore Event B is an impossible event.

- E) **Complementary Event:** Let A be an event defined on a sample space S. Therefore $A \subset S$. The complement of event A is the set containing all the elements in sample space S but not in A, which is denoted by A' or \bar{A} or A^c .

- $\therefore A'$ or \bar{A} or $A^c = \{a \mid a \in S, a \notin A\}$

Ex. Two coins are tossed simultaneously.

- \therefore Sample Space $S = \{HH, HT, TH, TT\}$
 $\therefore n(S) = 4$

Let event A: both the coins show tails.

- $\therefore A = \{TT\} \therefore n(A) = 1$

- $\therefore A' = \{HH, HT, TH\} \therefore n(A') = 3$

That is coins show at least one head.

$$n(A) + n(A') = n(S)$$

7.2 Algebra of Events

Since events represent subsets, the operations in set theory are very useful to describe algebra of events and to work out problems in probability.

- A) **Union of two events:** Let A and B be any two events defined on the sample space S. Then union of two events is denoted by $A \cup B$ and is defined as occurrence of at least one of the events. Either event A occurs or event B occurs or both occur.

- $\therefore A \cup B = \{x \mid x \in A \text{ or } x \in B \text{ or both}\}$

Ex. Sample Space S = All positive integers up to 50

Let event A: Set of numbers divisible by 6.

- $\therefore A = \{6, 12, 18, 24, 30, 36, 42, 48\}$
 Let event B: Set of numbers divisible by 9.
 $\therefore B = \{9, 18, 27, 36, 45\}$
 $\therefore A \cup B = \{6, 9, 12, 18, 24, 27, 30, 36, 42, 45, 48\}$.

B) Exhaustive Events: Two events A and B defined on the sample space S are said to be Exhaustive Events if $A \cup B = S$

For example :

Let event A : die shows a number less than or equal to 4.

- $\therefore A = \{1, 2, 3, 4\}$
 Let event B: die shows a number greater than or equal to 2.
 $\therefore B = \{2, 3, 4, 5, 6\}$
 $\therefore A \cup B = \{1, 2, 3, 4, 5, 6\} = S$
 \therefore A and B are exhaustive events.

C) Intersection of two events: Let A and B be any two events defined on the sample space S. Then intersection of two events is denoted by $A \cap B$ and is defined as simultaneous occurrence of both the events.

- $\therefore A \cap B = \{x \mid x \in A \text{ and } x \in B\}$
 Ex. A ticket is drawn from a box containing tickets numbered 1 to 50.
 \therefore Sample Space $S = \{1, 2, 3, 4, \dots, 50\}$
 Let event A: number on ticket is divisible by 4.
 $\therefore A = \{4, 8, 12, 16, 20, 24, 28, 32, 36, 40, 44, 48\}$
 Let event B: number of ticket is divisible by 5.
 $\therefore B = \{5, 10, 15, 20, 25, 30, 35, 40, 45, 50\}$
 $\therefore A \cap B = \{20, 40\}$

D) Mutually Exclusive Events: Two events A and B defined on the sample space are said to be mutually exclusive if they cannot occur simultaneously in a single trial that is occurrence of any one event prevents the occurrence of other event or $A \cap B = \phi$. It can also be said that A and B are disjoint sets.

Example : Consider the experiment, where a ticket drawn from a box containing tickets numbered 1 to 50. Sample space $S = \{1, 2, 3, 4, \dots, 50\}$

Let event A: number on ticket is divisible by 4.

- $\therefore A = \{4, 8, 12, 16, 20, 24, 28, 32, 36, 40, 44, 48\}$

Let event B: number on ticket is divisible by 13.

- $\therefore B = \{13, 26, 39\}$
 $\therefore A \cap B = \{\} = \phi$ i.e. number of tickets which is divisible by 4 and 13, which is not possible in a single trial. \therefore A and B are mutually exclusive events.

Note: If two events A and B defined on the sample space S are mutually exclusive and exhaustive, then they are complementary events.

i.e. if $A \cup B = S$ and $A \cap B = \phi$ then A and B are complementary events.

Table 7.1

Set Notation	Interpretation	Venn Diagram
A' or \bar{A} or $A^c = S - A$ where 'S' is sample space and $A \subset S$	Complement of event A i.e. not A	
$A \cup B$	Occurrence of at least one event	
$A \cap B$	Occurrence of both the event	
$(A' \cap B) \cup (A \cap B')$	Occurrence of exactly one event	
$A' \cap B' = (A \cup B)'$	Neither A nor B occur	

SOLVED EXAMPLES

Example 1: Write the sample space of the experiment 'coin and a die are thrown simultaneously'

Solution:

Sample space $S = \{(H,1), (H,2), (H,3), (H,4), (H,5), (H,6), (T,1), (T,2), (T,3), (T,4), (T,5), (T,6)\}$

Example 2: Sunita and Samrudhi who live in Mumbai wish to go on holiday to Delhi together. They can travel to Delhi from Mumbai either by car or by train or plane and on reaching Delhi they can go for city-tour either by bus or Taxi. Describe the sample space, showing all the combined outcomes of different ways they could complete city-tour from Mumbai.

Solution: Sample space

$S = \{(car, bus), (car, taxi), (train, bus), (train, taxi), (plane, bus), (plane, taxi)\}$

Example 3: Three coins are tossed. Events E_1, E_2, E_3 and E_4 are defined as follows.

E_1 : Occurrence of at least two heads.

E_2 : Occurrence of at least two tails.

E_3 : Occurrence of at most one head.

E_4 : Occurrence of two heads.

Write the sample space and events E_1, E_2, E_3 and E_4 .

Find $E_1 \cup E_4, E_3'$. Also check whether

i) E_1 and E_2 are mutually exclusive

ii) E_2 and E_3 are equal

Solution: Sample space

$S = \{HHH, HHT, HTH, HTT, THH, THT, TTH, TTT\}$

$E_1: \{HHH, HHT, HTH, THH\}$

$E_2: \{HTT, THT, TTH, TTT\}$

$E_3: \{HTT, THT, TTH, TTT\}$

$E_4: \{HHT, HTH, THH, \}$

$E_1 \cup E_4 = \{HHT, HTH, THH, HHH\}$

$E_3' = \{HHH, HHT, HTH, THH\}$

i) $E_1 \cap E_2 = \{\} = \phi$

$\therefore E_1$ and E_2 are mutually exclusive.

ii) E_2 and E_3 are equal.

EXERCISE 7.1

- 1) State the sample Space and $n(S)$ for the following random experiments.
 - a) A coin is tossed twice. If a second throw results in tail, a die is thrown.
 - b) A coin is tossed twice. If a second throw results in head, a die is thrown, otherwise a coin is tossed.
- 2) In a bag there are three balls; one black, one red and one green. Two balls are drawn one after another with replacement. State sample space and $n(S)$.
- 3) A coin and die are tossed. State sample space of following events.
 - a) A: Getting a head and an even number.
 - b) B: Getting a prime number.
 - c) C: Getting a tail and perfect square.
- 4) Find total number of distinct possible outcomes $n(S)$ for each of the following random experiments.
 - a) From a box containing 25 lottery tickets any 3 tickets are drawn at random.
 - b) From a group of 4 boys and 3 girls, any two students are selected at random.
 - c) 5 balls are randomly placed into five cells, such that each cell will be occupied.
 - d) 6 students are arranged in a row for photograph.
- 5) Two dice are thrown. Write favourable outcomes for the following events.
 - a) P: Sum of the numbers on two dice is divisible by 3 or 4.
 - b) Q: Sum of the numbers on 2 dice is 7.

- c) R: Sum of the numbers on two dice is a prime number.
Also check whether i) events P and Q are mutually exclusive and exhaustive.
ii) Events Q and R are mutually exclusive and exhaustive.
- 6) A card is drawn at random from an ordinary pack of 52 playing cards. State the number of elements in the sample space if consideration of suits
- is not taken into account.
 - is taken into account.
- 7) Box-I contains 3 red (R_{11}, R_{12}, R_{13}) and 2 blue (B_{11}, B_{12}) marbles while Box-II contains 2 red (R_{21}, R_{22}) and 4 blue ($B_{21}, B_{22}, B_{23}, B_{24}$) marbles. A fair coin is tossed. If the coin turns up heads, a marble is chosen from Box-I; if it turns up tails, a marble is chosen from Box-II. Describe the sample space.
- 8) Consider an experiment of drawing two cards at random from a bag containing 4 cards marked 5, 6, 7 and 8. Find the sample space if cards are drawn
- with replacement.
 - without replacement.



Let's Learn

7.3 CONCEPT OF PROBABILITY :

In any random experiment there is always uncertainty as to whether a particular event will or will not occur. It is convenient to assign a number between 0 and 1, as a measure of chance, with which we can expect the event to occur. If, for example, the chance (or probability) of a particular event is $1/4$, we would say that there is 25% chance it will occur and 75% chance that it will not occur. Assignment of real numbers (between 0 and 1) to the events defined in a sample space S is known as the probability assignment.

Some elementary properties of probability:

From the above axioms, the following useful properties of probability can be obtained.

- If A' is the complement of A, then $P(A') = 1 - P(A)$

Note : $\frac{P(A)}{P(A')}$ is called odds ratio in favour of A.

- For any event A in S, we have $0 \leq P(A) \leq 1$
- If ϕ is null set (i.e. impossible event), then $P(\phi) = 0$
- If $A \subset B$, then $P(A) \leq P(B)$
- If A and B are any two events, then $P(A \cap B') = P(A) - P(A \cap B)$

SOLVED EXAMPLES

Example 1: If $A \cup B \cup C = S$ (the sample space) and A, B and C are mutually exclusive events, can the following represent probability assignment?

- $P(A) = 0.2, P(B) = 0.7, P(C) = 0.1$
- $P(A) = 0.4, P(B) = 0.6, P(C) = 0.2$

Solution:

$$\begin{aligned} \text{i) Since } P(S) &= P(A \cup B \cup C) \\ &= P(A) + P(B) + P(C) \\ &\quad \text{[using axiom 3]} \\ &= 0.2 + 0.7 + 0.1 = 1 \end{aligned}$$

$$\text{and } 0 \leq P(A), P(B), P(C) \leq 1$$

\therefore Using axiom 1, 2 and 3 of axiomatic definition of probability $P(A)$, $P(B)$ and $P(C)$ represent probabilities of the events A, B and C respectively.

$$\begin{aligned} \text{ii) Since} \\ P(S) &= P(A \cup B \cup C) \\ &= P(A) + P(B) + P(C) \\ &\quad \text{[using axiom 3]} \\ &= 0.4 + 0.6 + 0.2 = 1.2 \neq 1 \end{aligned}$$

$\therefore P(A), P(B)$ and $P(C)$ cannot represent probability assignment.

Example 2: A fair die is thrown. What is probability of getting a number multiple of 3?

Solution: Random experiment is , a fair die is thrown.

$$\therefore \text{Sample space } S = \{1, 2, 3, 4, 5, 6\}$$

$$\therefore n(S) = 6$$

Let A be the event that number on die is multiple of 3.

$$\therefore A = \{3, 6\} \therefore n(A) = 2$$

$$\therefore P(A) = 2/6 = 1/3$$

Example 3: One card is drawn at random from a pack of 52 cards. What is the probability that it is a King or Queen?

Solution: Random Experiment = One card is drawn at random from a pack of 52 cards

$$\therefore n(S) = {}^{52}C_1 = 52.$$

Let event A: Card drawn is King

and event B: Card drawn is Queen.

Since pack of 52 cards contains, 4 king cards from which any one king card can be drawn in ${}^4C_1 = 4$ ways.

$$\therefore n(A) = 4 \therefore P(A) = n(A)/n(S) = 4/52 = \frac{1}{13}$$

Similarly, a pack of 52 cards contains, 4 queen cards from which any one queen card can be drawn in ${}^4C_1 = 4$ ways. $\therefore n(B) = 4$

$$\therefore P(B) = n(B)/n(S) = 4/52 = \frac{1}{13}$$

Since A and B are mutually exclusive events

\therefore required probability $P(\text{king or queen})$

$$= P(A \cup B) = P(A) + P(B) = 4/52 + 4/52 = 2/13$$

Example 4: The sample space S of a random experiment is given by $S = \{a_1, a_2, a_3, a_4\}$ with probabilities $P(a_1) = 0.3, P(a_2) = 0.1, P(a_3) = 0.4$ and $P(a_4) = 0.2$. Consider events A and B as: $A = \{a_1, a_2\}$ and $B = \{a_2, a_3, a_4\}$. Determine the following probabilities. i) $P(A)$ ii) $P(B)$ iii) $P(A')$ iv) $P(A \cap B)$ v) $P(A \cup B)$ vi) $P(A' \cap B')$. Also check

whether A and B are mutually exclusive and exhaustive?

Solution:

$$\text{i) } P(A) = P(a_1) + P(a_2) = 0.3 + 0.1 = 0.4 \text{ (using property 7)}$$

$$\text{ii) } P(B) = P(a_2) + P(a_3) + P(a_4) = 0.1 + 0.4 + 0.2 = 0.6 \text{ (using property 7)}$$

$$\text{iii) } P(A') = 1 - P(A) = 1 - 0.4 = 0.6 \text{ (using property 1)}$$

$$\text{iv) } A \cap B = \{a_2\}$$

$$\therefore P(A \cap B) = P(a_2) = 0.1$$

$$\text{v) } A \cup B = \{a_1, a_2, a_3, a_4\}$$

$$\therefore P(A \cup B) = P(a_1) + P(a_2) + P(a_3) + P(a_4) = 1$$

Or

using property 6, we have

$$P(A \cup B) = P(A) + P(B) - P(A \cap B) = 0.4 + 0.6 - 0.1 = 1$$

$$\text{vi) } P(A' \cap B') = P(A \cup B)' \text{ (using De Morgan's law)}$$

$$= 1 - P(A \cup B) = 1 - 1 = 0$$

Since $A \cap B = \{a_2\} \neq \phi$ therefore A and B are not mutually exclusive events but $A \cup B = \{a_1, a_2, a_3, a_4\} = S$, therefore A and B are exhaustive events.

Example 5: Five men in a company of 20 are graduates. If 3 men are picked out of 20 at random, what is the probability that they are all graduates? What is the probability of at least one graduate?

Solution: Out of 20 men, any 3 men can be selected in ${}^{20}C_3$

Let event A: All 3 selected men are graduates.

Out of 5 graduate men any three men can be selected in 5C_3 ways.

\therefore required probability

$$P(A) = {}^5C_3 / {}^{20}C_3 = 10/1140 = 1/114$$

Let event B: At least one graduate man is selected.

$\therefore B'$ is the event that no graduates man is selected.

Since out of 20 men, 5 men are graduates, therefore from the remaining 15 non-graduate men any three non-graduates can be selected in ${}^{15}C_3$ ways.

$$\therefore P(B') = \frac{{}^{15}C_3}{{}^{20}C_3} = \frac{455}{1140} = \frac{91}{228}$$

\therefore required probability

$$P(B) = 1 - P(B') = 1 - \frac{91}{228} = \frac{137}{228}$$

Example 6: Find the probability if letters of the word STORY are arranged, so that

- T and Y are always together.
- Begin with T and end with Y.

Solution: The word STORY consists of 5 different letters, which can be arranged among themselves in $5!$ ways.

$$n(s) = 5! = 120.$$

Let us consider T and Y as a single letter say X. Therefore, now we have four different letters X, S, O and R which can be arranged themselves in $4! = 24$ different ways. After this is done, two letters T and Y can be arranged themselves in $2! = 2$ ways. Therefore, by fundamental principle, total number of arrangements in which T and Y are always together is $24 \times 2 = 48$.

$$\therefore \text{required probability } P(A) = \frac{n(A)}{n(s)} = \frac{48}{120} = \frac{2}{5}$$

Let event B: An arrangement begins with T and ends with Y.

Remaining 3 letters in the middle can be arranged in $3! = 6$ different ways.

$$\therefore \text{required probability } P(B) = \frac{6}{120} = \frac{1}{20}$$

EXERCISE 7.2

- A fair die is thrown two times. Find the chance that
 - Product of the numbers on the upper face is 12.
 - Sum of the numbers on the upper face is 10.
 - Sum of the numbers on the upper face is at least 10.
- Sum of the numbers on the upper face is 4.
 - The first throw gives an odd number and second throw gives multiple of 3.
 - Both the time die shows same number (doublet)
- Two cards are drawn from a pack of 52 cards. Find the probability that
 - Both are black.
 - Both are diamond.
 - Both are ace cards.
 - Both are face cards.
 - One is spade and other is non-spade.
 - Both are from same suit.
 - Both are from same denomination.
- Four cards are drawn from a pack of 52 cards. Find the probability that
 - 3 are king and 1 is jack.
 - All the cards are from different suit.
 - At least one heart.
 - All cards are club and one of them a jack.
- A bag contains 15 balls of three different colours: Green, Black and Yellow. A ball is drawn at random from the bag. The probability of green ball is $\frac{1}{3}$. The probability of yellow is $\frac{1}{5}$.
 - What is the probability of black ball?
 - How many balls are green, black and yellow?
- A box contains 75 tickets numbered 1 to 75. A ticket is drawn at random from the box. What is the probability that,
 - Number on ticket is divisible by 6?
 - Number on ticket is perfect square?
 - Number on ticket is prime?
 - Number on ticket is divisible by 3 and 5?
- From a group of 8 boys and 5 girls a committee of five is to be formed. Find the probability that committee contains

- a) 3 boys and 2 girls
 b) At least 3 boys
- 7) A room has three sockets for lamps. From a collection of 10 light bulbs of which 6 are defective, a person selects 3 bulbs at random and puts them in socket. What is the probability that the room is lit?
- 8) The letters of the word LOGARITHM are arranged at random. Find the probability that
- Vowels are always together.
 - Vowels are never together.
 - Exactly 4 letters between G and H.
 - Begin with O and end with T.
 - Start with vowel and end with ends with consonant.
- 9) The letters of the word SAVITA are arranged at random. Find the probability that vowels are always together.



Let's Learn

7.4 ADDITION THEOREM

Statement: Let S be a sample space associated with the given random experiment. Let A and B be any two events defined on the sample space S . Then the probability of occurrence of at least one event is denoted by $P(A \cup B)$ and given by $P(A \cup B) = P(A) + P(B) - P(A \cap B)$

SOLVED EXAMPLES

Example 1: Two dice are thrown together. What is the probability that,

- Sum of the numbers is divisible by 3 or 4?
- Sum of the numbers is neither divisible by 3 nor 5?

Solution: Since two dice are thrown, therefore $n(S) = 36$

- Let event A : Sum of the numbers is divisible by 3

\therefore possible sums are 3, 6, 9, 12.
 $\therefore A = \{(1, 2), (1, 5), (2, 1), (2, 4), (3, 3), (3, 6), (4, 2), (4, 5), (5, 1), (5, 4), (6, 3), (6, 6)\}$
 $\therefore n(A) = 12 \therefore P(A) = n(A) / n(S) = 12/36$
 Let event B : Sum of the numbers is divisible by 4.
 \therefore possible sums are 4, 8, 12
 $\therefore B = \{(1, 3), (2, 2), (2, 6), (3, 1), (3, 5), (4, 4), (5, 3), (6, 2), (6, 6)\}$
 $\therefore n(B) = 9 \therefore P(B) = n(B) / n(S) = 9/36$
 \therefore Event $A \cap B$: Sum of the numbers is divisible by 3 and 4 i.e. divisible by 12.
 \therefore possible sum is 12
 $\therefore A \cap B = \{(6, 6)\}$
 $\therefore n(A \cap B) = 1$
 $\therefore P(A \cap B) = n(A \cap B) / n(S) = 1/36$
 \therefore required probability
 $= P(\text{Sum of the numbers is divisible by 3 or 4})$
 $= P(A \cup B) = P(A) + P(B) - P(A \cap B)$
 $= 12/36 + 9/36 - 1/36 = 20/36 = 5/9$

ii) Let event X : Sum of the numbers is divisible by 3
 \therefore possible sums are 3, 6, 9, 12
 $\therefore X = \{(1, 2), (1, 5), (2, 1), (2, 4), (3, 3), (3, 6), (4, 2), (4, 5), (5, 1), (5, 4), (6, 3), (6, 6)\}$
 $\therefore n(X) = 12 \therefore P(X) = n(X) / n(S) = 12/36$
 Let event Y : Sum of the numbers is divisible by 5.
 \therefore possible sums are 5, 10
 $\therefore Y = \{(1, 4), (2, 3), (3, 2), (4, 1), (4, 6), (5, 5), (6, 4)\}$
 $\therefore n(Y) = 7 \therefore P(Y) = n(Y) / n(S) = 7/36$
 \therefore Event $X \cap Y$: sum is divisible by 3 and 5
 $\therefore X \cap Y = \{\} = \phi$
 $[X \text{ and } Y \text{ are mutually exclusive events}]$
 $\therefore P(X \cap Y) = n(X \cap Y) / n(S) = 0$
 \therefore required probability = $P(\text{Sum of the numbers is neither divisible by 3 nor 5})$
 $= P(X' \cap Y') = P((X \cup Y)') = 1 - P(X \cup Y)$

$$= 1 - [P(X) + P(Y)]$$

$$= 1 - 19/36 = \frac{17}{36}$$

Example 2: The probability that a student will solve problem A is $2/3$, and the probability that he will not solve problem B is $5/9$. If the probability that student solves at least one problem is $4/5$, what is the probability that he will solve both the problems?

Solution: Let event A: student solves problem A

$$\therefore P(A) = \frac{2}{3}$$

event B: student solves problem B.

\therefore event B': student will not solve problem B.

$$\therefore P(B') = \frac{5}{9}$$

$$\therefore P(B) = 1 - P(B') = 1 - 5/9 = \frac{4}{9}$$

Probability that student solves at least one problem = $P(A \cup B) = \frac{4}{5}$

$$\therefore P(A \cup B) = P(A) + P(B) - P(A \cap B)$$

\therefore required probability = P(he will solve both the problems)

$$= P(A \cap B) = P(A) + P(B) - P(A \cup B)$$

$$= 2/3 + 4/9 - 4/5 = \frac{14}{45}$$

EXERCISE 7.3

- Two dice are thrown together. What is the probability that sum of the numbers on two dice is 5 or number on second die is greater than or equal to the number on the first die?
- A card is drawn from a pack of 52 cards. What is the probability that,
 - Card is either red or black?
 - Card is either red or face card?
- Two cards are drawn from a pack of 52 cards. What is the probability that,
 - both the cards are of same colour?
 - both the cards are either black or queens?
- A bag contains 50 tickets, numbered from 1 to 50. One ticket is drawn at random. What is the probability that,
 - number on the ticket is a perfect square or divisible by 4?
 - number on the ticket is a prime number or greater than 30?
- Hundred students appeared for two examinations. 60 passed the first, 50 passed the second and 30 passed in both. Find the probability that student selected at random
 - passed in at least one examination
 - passed in exactly one examination
 - failed in both examinations.
- If $P(A) = 1/4$, $P(B) = 2/5$ and $P(A \cup B) = 1/2$. Find the values of the following probabilities.
 - $P(A \cap B)$
 - $P(A \cap B')$
 - $P(A' \cap B)$
 - $P(A' \cup B')$
 - $P(A' \cap B')$
- A computer software company is bidding for computer program A and B. The probability that the company will get software A is $3/5$, the probability that the company will get software B is $1/3$ and the probability that company will get both A and B is $1/8$. What is the probability that the company will get at least one software?
- A card is drawn from well shuffled pack of 52 cards. Find the probability of it being heart or a queen.
- In a group of students, there are 3 boys and 4 girls. Four students are to be selected at random from the group. Find the probability that either 3 boys and 1 girl or 3 girls and 1 boy are selected.



Let's Learn

7.5 CONDITIONAL PROBABILITY:

Let S be a sample space associated with the given random experiment. Let A and B be any two events defined on the sample space S . Then the probability of occurrence of event A under the condition that event B has already occurred and $P(B) \neq 0$ is called conditional probability of event A given B and is denoted by $P(A/B)$.

Consider the following examples :

Example 1: A card is drawn from a pack of 52 cards, given that it is a red card, what is the probability that it is a face card.

Solution: Let event A : Red card is drawn and event B : face card is drawn

A card is drawn from a pack of 52 cards, therefore $n(S) = 52$. But we are given that red card is drawn, therefore our sample space reduces to event A only, which contains $n(A) = 26$ sample points. Event A is called reduced or truncated sample space. Out of 26 red cards, 6 cards are favourable for face cards.

$\therefore P[\text{card drawn is face card given that it is a red card}] = P[B/A] = 6/26 = 3/13$

Example 2: A pair of dice is thrown. If sum of the numbers is an odd number, what is the probability that sum is divisible by 3?

Solution: Let Event A : sum is an odd number.

Event B : Sum is divisible by 3.

A pair of dice is thrown, therefore $n(S) = 36$. But we are given that sum is odd, therefore our sample space reduces to event A only as follows:

$A = \{(1,2), (1,4), (1,6), (2,1), (2,3), (2,5), (3,2), (3,4), (3,6), (4,1), (4,3), (4,5), (5,2), (5,4), (5,6), (6,1), (6,3), (6,5)\}$

$\therefore n(A) = 18$

Out of 18 sample points following 6 sample points are favourable for occurrence of event B

$B = \{(1, 2), (2, 1), (3, 6), (4, 5), (5, 4), (6, 3)\}$

$\therefore P[\text{sum is divisible by 3 given that sum is an odd number}] = P(B/A) = 6/18 = 1/3$

7.5.1 Let S be a finite sample space, associated with the given random experiment, containing equally likely outcomes. Then we have the following result.

Statement: Conditional probability of event A given that event B has already occurred is given by

$$P(A|B) = \frac{P(A \cap B)}{P(B)}, P(B) \neq 0$$

SOLVED EXAMPLES

Example 1: Find the probability that a single toss of a die will result in a number less than 4 if it is given that the toss resulted in an odd number.

Solution: Let event A : toss resulted in an odd number and

Event B : number is less than 4

$\therefore A = \{1, 3, 5\} \therefore P(A) = 3/6 = 1/2$

$B = \{1, 2, 3\} \therefore A \cap B = \{1, 3\}$

$\therefore P(A \cap B) = 2/6 = 1/3$

$\therefore P(\text{number is less than 4 given that it is odd})$

$= P(B/A) = P(A \cap B) / P(A) = (1/3) / (1/2) = 2/3$

Example 2: If $P(A') = 0.7$, $P(B) = 0.7$, $P(B/A) = 0.5$, find $P(A/B)$ and $P(A \cup B)$.

Solution: Since $P(A') = 0.7$

$P(A) = 1 - P(A') = 1 - 0.7 = 0.3$

Now $P(B/A) = P(A \cap B) / P(A)$

$\therefore 0.5 = P(A \cap B) / 0.3$

$\therefore P(A \cap B) = 0.15$

Again $P(A/B) = P(A \cap B) / P(B)$

$= 0.15 / 0.7$

$\therefore P(A/B) = 3/14$

Further, by addition theorem

$$P(A \cup B) = P(A) + P(B) - P(A \cap B)$$

$$= 0.3 + 0.7 - 0.15 = 0.85$$

7.5.2 Multiplication theorem:

Statement: Let S be sample space associated with the given random experiment. Let A and B be any two events defined on the sample space S. Then the probability of occurrence of both the events is denoted by $P(A \cap B)$ and is given by

$$P(A \cap B) = P(A).P(B/A) = P(B).P(A/B)$$

SOLVED EXAMPLES

Example 1: Two cards are drawn from a pack of 52 cards one after other without replacement. What is the probability that both cards are ace cards?

Solution: Let event A: first card drawn is an Ace card.

Let event B: second card drawn is an Ace card.

∴ required probability = $P(\text{both are Ace cards}) = P(A \cap B) = P(A)P(B/A)$

$$\text{Now } P(A) = 4/52 = 1/13$$

Since first ace card is not replaced in the pack, therefore now we have 51 cards containing 3 ace cards

∴ Probability of getting second ace card under the condition that first ace card is not replaced in the pack = $P(B/A) = 3/51 = 1/17$

∴ $P(\text{both are ace cards}) = P(A \cap B) = P(A)P(B/A) = (1/13) \times (1/17) = 1/221$

Example 2: An urn contains 4 black and 6 white balls. Two balls are drawn one after the other without replacement, what is the probability that

- (i) both balls are black?
- (ii) the 2nd ball is black ?

Solution: Let event A: first ball drawn is black.

Event B: second ball drawn is black.

∴ required probability = $P(\text{both are black balls}) = P(A \cap B) = P(A)P(B/A)$

$$\text{Now } P(A) = 4/10$$

Since first black ball is not replaced in the urn, therefore now we have 9 balls containing 3 black balls.

∴ Probability of getting second black ball under the condition that first black ball is not replaced in the pack = $P(B/A) = 3/9$

∴ $P(\text{both are black balls}) = P(A \cap B) = P(A)P(B/A) = (4/10) \times (3/9) = 2/15$

The first ball can be black or non-black (white)

case 1 : The first ball is white : The probability of second ball is black is

$$\frac{6}{10} \times \frac{4}{9} = \frac{4}{15}$$

case 2 : The first ball is black : The probability of second ball is black is

$$\frac{4}{10} \times \frac{3}{9} = \frac{2}{15}$$

∴ The required probability

$$= \frac{4}{15} + \frac{2}{15} = \frac{6}{15} = \frac{2}{5}$$

7.5.3 Independent Events:

Let S be sample space associated with the given random experiment. Let A and B be any two events defined on the sample space S. If the occurrence of one event does not affect the occurrence of other event, then two events A and B are said to be independent.

$$\text{i.e. if } P(A/B) = P(A/B') = P(A) \text{ or } P(B/A) = P(B/A') = P(B)$$

Then A and B are independent events.

Corollary : If A and B are independent events then $P(A \cap B) = P(A).P(B)$

In general, if $A_1, A_2, A_3, \dots, A_n$ are n independent events, then

$$P(A_1 \cap A_2 \cap \dots \cap A_n) = P(A_1).P(A_2) \dots P(A_n)$$

Remark:

- If A and B are independent events then
- A and B' are also independent events
 - A' and B' are also independent events
 - A' and B are also independent events

- $P(A \cap B') = P(A)P(B') = 1/5$
- $P(A' \cap B) = P(A')P(B) = 4/15$
- $P(A' \cap B') = P(A')P(B') = 2/15$
- $P(A \cup B) = P(A) + P(B) - P(A \cap B) = 13/15$

SOLVED EXAMPLES

Example 1: Two cards are drawn at random one after the other. Given that first card drawn is non-face red card and second card is face card, check whether events are independent if the cards are drawn

- without replacement ?
- with replacement ?

Solution: Let event A: first card drawn is a non-face red card and event B: second card drawn is face card.

- $\therefore P(A) = 20/52 = 5/13$ and $P(B) = 12/52 = 3/13$
 \therefore required probability = $P(\text{second card drawn is face card given that it is a red card})$
- Without replacement: Since first non-face red card is not replaced, therefore now we have 51 cards containing 12 face cards.
 $\therefore P(B/A) = 12/51 \neq P(B)$. In this case A and B are not independent.
 - With replacement: Since first non-face red is replaced, therefore now again we have 52 cards containing 12 face cards.
 $\therefore P(B/A) = 12/52 = 3/13 = P(B)$.
In this case A and B are independent.

Example 2: If A and B are two independent events and $P(A) = 3/5$, $P(B) = 2/3$, find

- $P(A \cap B)$
 - $P(A \cap B')$
 - $P(A' \cap B)$
 - $P(A' \cap B')$
 - $P(A \cup B)$
- Solution:** $P(A) = 3/5 \therefore P(A') = 1 - P(A) = 2/5$
 $P(B) = 2/3 \therefore P(B') = 1 - P(B) = 1/3$
- $P(A \cap B) = P(A)P(B) = 2/5$

EXERCISE 7.4

- Two dice are thrown simultaneously, if at least one of the dice show a number 5, what is the probability that sum of the numbers on two dice is 9?
- A pair of dice is thrown. If sum of the numbers is an even number, what is the probability that it is perfect square?
- A box contains 11 tickets numbered from 1 to 11. Two tickets are drawn at random with replacement. If the sum is even, find the probability that both the numbers are odd.
- A card is drawn from a well shuffled pack of 52 cards. Consider two events A and B as A: a club card is drawn. B: an ace card is drawn. Determine whether events A and B are independent or not.
- A problem in statistics is given to three students A, B and C. Their chances of solving the problem are $1/3$, $1/4$ and $1/5$ respectively. If all of them try independently, What is the probability that,
 - problem is solved?
 - problem is not solved?
 - exactly two students solve the problem?
- The probability that a 50-year old man will be alive till age 60 is 0.83 and the probability that a 45-year-old woman will be alive till age 55 is 0.97. What is the probability that a man whose age is 50 and his wife whose age is 45 will both be alive for next 10 years?
- In an examination, 30% of the students have failed in subject I, 20% of the students have

failed in subject II and 10% have failed in both subject I and subject II. A student is selected at random, what is the probability that the student

- a) has failed in subject I, if it is known that he is failed in subject II?
 - b) has failed in at least one subject?
 - c) has failed in exactly one subject?
- 8) One shot is fired from each of the three guns. Let A, B and C denote the events that the target is hit by first, second and third gun respectively. assuming that A, B and C are independent events and that $P(A) = 0.5$, $P(B) = 0.6$ and $P(C) = 0.8$, then find the probability that at least one hit is registered.
 - 9) A bag contains 10 white balls and 15 black balls. Two balls are drawn in succession without replacement. What is the probability that,
 - a) first is white and second is black?
 - b) one is white and other is black?
 - 10) An urn contains 4 black, 5 white and 6 red balls. Two balls are drawn one after the other without replacement, what is the probability that at least one ball is black?
 - 11) Two balls are drawn from an urn containing 5 green, 3 blue and 7 yellow balls one by one without replacement. What is the probability that at least one ball is blue?
 - 12) A bag contains 4 blue and 5 green balls. Another bag contains 3 blue and 7 green balls. If one ball is drawn from each bag, what is the probability that two balls are of the same colour?
 - 13) Two cards are drawn one after other from a pack of 52 cards with replacement. What is the probability that both the cards drawn are face cards?



Let's Remember

- **Random experiment** : A random experiment is an action in which all the possible results are known in advance and are equally likely.
- **Outcome** : The result of a random experiment is called "Outcome of experiment".
- **Equally likely outcomes** : The outcomes of random experiment are said to be equally likely, if all of them have equal chance to occur.
- **Sample space** : The set of all possible outcomes of a random experiment is called the sample space. It is denoted by S or Ω . Each element of the sample space is called a sample point. The number of elements in the sample space is denoted by $n(S)$ or $n(\Omega)$.
- **Event** : A subset of the sample space is called an event.
- **Simple or elementary event** : A subset of sample space, consisting of a single element is called a simple or elementary event. Every sample point of the sample space S forms an elementary event.
- **Sure Event** : An event which contains all the sample points of the sample space S, is called as a sure event.
- **Impossible Event** : An event which does not contain any sample point of the sample space S is called an impossible event. Null set ϕ represent an impossible event.
- **Complementary Event** : Let A be an event defined on a sample space S. Therefore $A \subset S$. The complement of event A is the set containing all the elements in sample space S but not in A, which is denoted by A' or \bar{A} or A^c .

- **Union of two events :** Let A and B be any two events defined on the sample space S. Then union of two events is denoted by $A \cup B$ and is defined as occurrence of at least one of the events. Either event A occurs or event B occurs or both occur.
- **Exhaustive Events :** Two events A and B defined on the sample space S are said to be Exhaustive Event if $A \cup B = S$
- **Intersection of two events :** Let A and B be any two events defined on the sample space S. Then intersection of two events is denoted by $A \cap B$ and is defined as simultaneous occurrence of both the events.
- **Mutually Exclusive Events :** Two events A and B defined on the sample space are said to be mutually exclusive if they cannot occur simultaneously in a single trial that is occurrence of any one event prevents the occurrence of other event or $A \cap B = \phi$. it can also be said that A and B are disjoint sets.
- If A' is the compliment of A, then $P(A') = 1 - P(A)$
- For any event A in S, we have $0 \leq P(A) \leq 1$
- If ϕ is null set (i.e. impossible event), then $P(\phi) = 0$
- If $A \subset B$, then $P(A) \leq P(B)$
- If A and B are any two events, then $P(A \cap B') = P(A) - P(A \cap B)$
- If A and B are any two events, then $P(A \cup B) = P(A) + P(B) - P(A \cap B)$
- In general, if event $A = A_1 \cup A_2 \cup A_4 \dots \cup A_m$, where $A_1, A_2, A_4 \dots A_m$, are mutually exclusive events in S, then,
- **Addition theorem :** Let S be a sample space associated with the given random experiment. Let A and B be any two events defined on the sample space S. Then the probability of occurrence of at least one event is denoted by $P(A \cup B)$ and given by $P(A \cup B) = P(A) + P(B) - P(A \cap B)$

- **Conditional Probability :**

If A and B are any two events defined on the same sample space S, then conditional probability of event A given that event B has already occurred is denoted by $P(A/B)$

$$\therefore P(A/B) = P(A \cap B) / P(B), P(B) \neq 0$$

Similarly,

$$P(B/A) = P(A \cap B) / P(A),$$

$$P(A) \neq 0$$

- **Multiplication theorem :** Let S be sample space associated with the given random experiment. Let A and B be any two events defined on the sample space S. Then the probability of occurrence of both the events is denoted by $P(A \cap B)$ and is given by

$$\begin{aligned} P(A \cap B) &= P(A) \cdot P(B/A) \\ &= P(B) \cdot P(A/B) \end{aligned}$$

- **Independent Events :** Let S be sample space associated with the given random experiment. Let A and B be any two events defined on the sample space S. If the occurrence of one event does not affect the occurrence of other event, then two events A and B are said to be independent.

i.e. if $P(A/B) = P(A/B') = P(A)$ or

$$P(B/A) = P(B/A') = P(B)$$

- If A and B are independent events then $P(A \cap B) = P(A) \cdot P(B)$

- $\frac{P(A)}{P(A')}$ is called odds ratio in favour of A.

- If A and B are independent events then
 - a) A and B' are also independent events
 - b) A' and B are also independent events.

MISCELLANEOUS EXERCISE - 7

- 1) From a group of 2 men (M_1, M_2) and three women (W_1, W_2, W_3), two persons are selected. Describe the sample space of the experiment. If E is the event in which one

- man and one woman are selected, then which are the cases favourable to E?
- 2) Three groups of children contain respectively 3 girls and 1 boy, 2 girls and 2 boys and 1 girl and three boys. One child is selected at random from each group. What is the chance that three selected consists of 1 girl and 2 boys.
 - 3) A room has 3 sockets for lamps. From a collection of 10 light bulbs 6 are defective. A person selects 3 at random and puts them in every socket. What is the probability that the room will be lit?
 - 4) There are 2 red and 3 black balls in a bag. 3 balls are taken out at random from the bag. Find the probability of getting 2 red and 1 black ball or 1 red and 2 black balls.
 - 5) A box contains 25 tickets numbered 1 to 25. Two tickets are drawn at random. What is the probability that the product on the number is even?
 - 6) A, B and C are mutually exclusive and exhaustive events associated with the random experiment. Find $P(A)$, given that $P(B) = (3/2) P(A)$ and $P(C) = (1/2) P(B)$.
 - 7) An urn contains four tickets marked with numbers 112, 121, 122, 222 and one ticket is drawn at random. Let $A_i (i = 1, 2, 3)$ be the event that i^{th} digit of the number of the ticket drawn is 1. Discuss the independence of the events A_1, A_2 and A_3 .
 - 8) The odds against a certain event are 5:2 and odds in favour of another independent event are 6:5. Find the chance that at least one of the events will happen.
 - 9) The odds against the husband who is 55 years old living till he is 75 is 8:5 and it is 4:3 against his wife who is now 48, living till she is 68. Find the probability that
 - a) the couple will be alive 20 years hence
 - b) at least one of them will be alive 20 years hence.
 - 10) Two throws are made, the first with 3 dice and second with 2 dice. The faces of each die are marked with the number 1 to 6. What is the probability that the total in first throw is not less than 15 and at the same time the total in the second throw is not less than 8?
 - 11) Two-third of the students in a class are boys and rest are girls. It is known that the probability of girl getting first class is 0.25 and that of boy getting is 0.28. Find the probability that a student chosen at random will get first class.
 - 12) A number of two digits is formed using the digits 1, 2, 3, ..., 9. What is the probability that the number so chosen is even and less than 60?
 - 13) A bag contains 8 red balls and 5 white balls. Two successive draws of 3 balls are made without replacement. Find the probability that the first drawing will give 3 white balls and second drawing will give 3 red balls.
 - 14) The odds against student X solving a business statistics problem are 8:6. and odds in favour of student Y solving the same problem are 14:16
 - a) What is the chance that the problem will be solved, if they try independently?
 - b) What is the probability that neither solves the problem?

Activity 7.1

A bag contains 4 blue and 5 green balls. Another bag contains 3 blue and 7 green balls. A ball is drawn from each bag. Represent this data in a tree diagram. Hence find the probabilities to find

- (i) The two balls are of the same colour
- (ii) The two balls are of different colour

Activity 7.2

The population is categorized according to sex and employment status as follows :

	Employment	Unemployment	Total
Male	460	40	500
Female	140	260	400
Total	600	300	900

Represent this data in a tree digram. Hence find

- (i) The probability that the individual is man, knowing that the individual chosen is employed.
- (ii) The probability that the individual is unemployed, knowing that the individual is a female.



8. LINEAR INEQUALITIES



Let's Study

- Linear inequality.
- Solution of linear inequality.
- Graphical representation of solution of linear inequality in one variable.
- Graphical solution of linear inequality of two variable.
- Solution of system of linear inequalities in two variables.



Let's Recall

Overview

In earlier classes, we have studied equations in one variable and two variables and also solved some statement problems by translating them in the form of equations. Now a natural question arises: 'Is it always possible to translate a statement problem in the form of an equation?' For example, the height of all the students in the class is less than 170 cm. The classroom can occupy at most 60 benches. Here we get certain statements involving signs '<' (less than), '>' (greater than), \leq (less than or equal) and \geq (greater than or equal) which are known as inequalities.

In this chapter, we will study linear inequalities in one and two variables. The study of inequalities is very useful in solving problems in the field of Science, Mathematics, Statistics, Optimisation problems, Economics, Psychology, etc.



Let's Learn

8.1 Linear inequality :

Let us consider the following situations:

- (i) Ramesh goes to market with ₹ 100 to buy chocolates. The price of one chocolate is ₹ 15. If he buys x chocolates, then the total amount spent by him is ₹ $15x$. Since he has to buy chocolates in whole numbers only, he may not be able to spend the entire amount of ₹ 100. (Why?)

As ₹ $15x$ cannot exceed ₹ 100, ₹ $15x$ must be less than Rs. 100.

That is $15x < 100$ (1)

The statement (1) is not an equation as it does not involve the sign of equality.

- (ii) Radhika has ₹ 200 and wants to buy some notebooks and pens. The cost of one notebook is Rs. 40 and that of a pen is ₹ 20. In this case, if Radhika buys x notebooks and y pens, then she spends ₹ $(40x + 20y)$.

Therefore $40x + 20y \leq 200$ (2)

Definition: A statement involving real numbers or two algebraic expressions and symbols '>', '<', ' \leq ', ' \geq ' is called an inequality or inequation. Statements (1) and (2) above are inequalities.

Some more examples :

- (i) $9 > 5$, $x < 5$, $x + y < 5$, $x^2 - x + 3 \leq 5$
- (ii) Inequalities which involve linear expression are called linear inequalities.

For example, $x > 3$, $y > 5$, $x - y < 2$

(iii) An inequality may contain more than one variable and it can be linear, quadratic or cubic etc. For example, $3x - 2 < 0$ is a linear inequality in one variable, $2x + 3y < 4$ is a linear inequality in two variables and $x^2 - 2x + 3 \geq 0$ is a quadratic inequality in one variable.

(iv) Inequalities involving the symbol ' $>$ ' or ' $<$ ' are called **strict inequalities**.

For example, $3x - y > 5$, $x < 3$.

(v) Inequalities involving the symbol ' \leq ' or ' \geq ' are called **slack inequalities**.

For example, $2x + y \leq 4$, $3x - 5y \geq 6$

Some more examples of inequalities are:

$$ax + b < 0 \quad \dots\dots\dots (3)$$

$$ax + b > 0 \quad \dots\dots\dots (4)$$

$$ax + b \leq 0 \quad \dots\dots\dots (5)$$

$$ax + b \geq 0 \quad \dots\dots\dots (6)$$

$$ax + by < c \quad \dots\dots\dots (7)$$

$$ax + by > c \quad \dots\dots\dots (8)$$

$$ax + by \leq c \quad \dots\dots\dots (9)$$

$$ax + by \geq c \quad \dots\dots\dots (10)$$

$$ax^2 + bx + c \leq 0 \quad \dots\dots\dots (11)$$

$$ax^2 + bx + c > 0 \quad \dots\dots\dots (12)$$

Here (3), (4), (7), (8) and (12) are strict inequalities, while (5), (6), (9), (10) and (11) are slack inequalities. Inequalities from (3) to (6) are linear inequalities in one variable x when $a \neq 0$, while inequalities from (7) to (10) are linear inequalities in two variables x and y when $a \neq 0$, $b \neq 0$. Inequalities (11) and (12) are quadratic inequalities in one variable x when $a \neq 0$. In this Chapter, we shall study linear inequalities in one and two variables only.

8.2 Solution of linear inequality :

The value(s) of the variable(s) making the inequality a true statement are called solutions of inequality. The set of all **solutions of an inequality**

is called the **solution set** of the inequality. For example, $x - 2 \geq 0$ has infinite solutions as all real values of x greater than or equal to two make it a true statement. The inequality $x^2 + 4 \leq 0$ has no solution in **R** as no real value of x makes it a true statement.

An inequality can be solved by

(i) Adding (or subtracting) the same expression to (from) both sides without changing the sign of inequality.

(ii) Multiplying (or dividing) both sides by the same positive quantity without changing the sign of inequality.

However, if both sides of inequality are multiplied (or divided) by the same negative quantity, the sign of inequality is reversed, that is ' $>$ ' changes into ' $<$ ' and vice versa.

Representation of solution of linear inequality in one variable on the number line:

(i) If the inequality involves ' \leq ' or ' \geq ', we draw rigid circle (\bullet) on the number line to indicate that the number corresponding to the filled circle is included in the solution set.

(ii) If the inequality involves ' $>$ ' or ' $<$ ', we draw hollow circle (\circ) on the number line to indicate that the number corresponding to the open circle is excluded from the solution set.

8.3 Graphical representation of solution of linear inequality in one variable :

(a) (i) If the inequality involves ' \leq ' or ' \geq ', we draw the graph of the line as a thick line to indicate that the points on this line are included in the solution set.

(ii) If the inequality involves ' $>$ ' or ' $<$ ', we draw the graph of the line as dotted line to indicate that the points on the line are excluded from the solution set.

[Interval concept studied in Sets and Relations]

(b) Solution of a linear inequality in one variable can be represented on the numberline as well as in the plane. The solution of a linear inequality in two variables of the type $ax + by > c$, $ax + by \geq c$, $ax + by < c$ or $ax + by \leq c$ ($a \neq 0$ and $b \neq 0$) can be represented in the plane only.

(c) Two or more inequalities taken together form a system of inequalities. Solutions of a system of inequalities are common to all inequalities in the system.

Important results

(a) If $a, b \in \mathbf{R}$ and $b \neq 0$ then

(i) $ab > 0$ or $\frac{a}{b} > 0$ implies a and b both have the same sign.

(ii) $ab < 0$ or $\frac{a}{b} < 0$ implies a and b have opposite signs.

(b) If a is any positive real number, that is, $a > 0$, then

(i) $|x| < a$ if and only if $-a < x < a$

(ii) $|x| \leq a$ if and only if $-a \leq x \leq a$

(iii) $|x| > a$ if and only if $x < -a$ or $x > a$

(iv) $|x| \geq a$ if and only if $x \leq -a$ or $x \geq a$

SOLVED EXAMPLES

Ex. 1 :

Solve the inequality $3x - 5 < x + 7$ and represent the solutions on the number line when (i) x is a natural number (ii) x is a whole number (iii) x is a real number

Solution: We have $3x - 5 < x + 7$

$\therefore 3x < x + 12$ (Adding 5 to both sides)

$\therefore 2x < 12$ (Subtracting x from both sides)

$\therefore x < 6$ (Dividing by 2 on both sides)

(i) Solution set is $\{1, 2, 3, 4, 5\}$

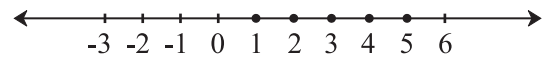

Fig. 8.1

(ii) Solution set is $\{0, 1, 2, 3, 4, 5\}$

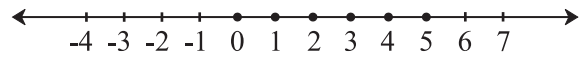

Fig. 8.2

(iii) Solution set is $\{x | x \in \mathbf{R} \text{ and } x < 6\} = (-\infty, 6)$, that is, any real number less than 6.

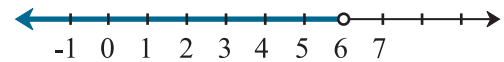

Fig. 8.3.

This is an infinite and unbounded set.

Ex. 2 : Solve $\frac{x-3}{x+3} > 2$ and represent the solutions on the number line.

Solution: We have $\frac{x-3}{x+3} > 2$

$$\frac{x-3}{x+3} > 2 \text{ subtracting 2 from both sides}$$

$$\frac{x-3-2(x+3)}{x+3} > 0 \text{ by simplification}$$

$$\frac{x-3-2x-6}{x+3} > 0$$

$$\frac{-x-9}{x+3} > 0$$

$$\frac{-(x+9)}{x+3} > 0$$

$$\frac{(x+9)}{x+3} < 0 \text{ multiplying by } -1$$

Either $x + 9 > 0$ and $x + 3 < 0$

or $x + 9 < 0$ and $x + 3 > 0$

Either $x > -9$ and $x < -3$

or $x < -9$ and $x > -3$

$x < -9$ and $x > -3$ is impossible
 $x > -9$ and $x < -3$ i.e. $-9 < x < -3$
 i.e. $x \in (-9, -3)$. This solution set is bounded.

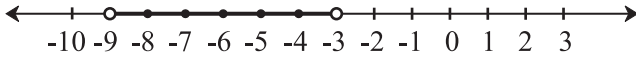

Fig. 8.4

Example 3: Solve $|4x - 3| \leq 9$ and represent the solutions on the number line.

Solution: We have $|4x - 3| \leq 9$

$$-9 \leq 4x - 3 \leq 9$$

$$-9 \leq 4x - 3 \text{ and } 4x - 3 \leq 9$$

$$-6 \leq 4x \text{ and } 4x \leq 12$$

$$-\frac{3}{2} \leq x \text{ and } x \leq 3 \text{ i.e. } x \in \left[-\frac{3}{2}, 3\right] \text{ this solution}$$

set is bounded but infinite.

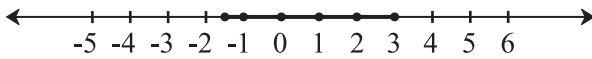

Fig. 8.5

Ex. 4 : Solve $1 \leq |x - 2| \leq 3$ and represent the solutions on the number line.

Solution: We have $1 \leq |x - 2| \leq 3$

$$|x - 2| \geq 1 \text{ and } |x - 2| \leq 3$$

$$x - 2 \leq -1 \text{ or } x - 2 \geq 1$$

$$\text{and } -3 \leq x - 2 \leq 3$$

$$x \leq 1 \text{ or } x \geq 3 \text{ and } -1 \leq x \leq 5$$

$$x \in (-\infty, 1] \text{ or } x \in [3, \infty) \text{ and } x \in [-1, 5]$$

$$x \in (-\infty, 1] \cup [3, \infty) \text{ and } x \in [-1, 5]$$

$x \in [-1, 1] \cup [3, 5]$ this solution set is bounded and infinite.

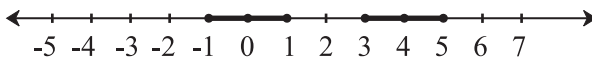

Fig. 8.6

Ex. 5 : The cost and revenue functions of a product are given by

$C(x) = 20x + 4000$ and $R(x) = 60x + 2000$, respectively, where x is the number of items produced and sold. How many items must be sold to gain profit?

Solution: We have, Profit = Revenue - Cost
 $= R(x) - C(x)$

$$= (60x + 2000) - (20x + 4000)$$

$$= 40x - 2000$$

To earn profit, $40x - 2000 > 0$

$$x > 50$$

Hence, the manufacturer must sell more than 50 items to gain profit.

Ex. 6 : Solve $7x + 3 < 5x + 9$. Show the graph of the solutions on number line.

Solution: We have $7x + 3 < 5x + 9$ or

$$2x < 6 \text{ or } x < 3$$

The graph of the solutions is shown in Fig8.7

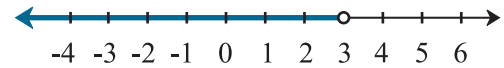

Fig. 8.7

Ex. 7 : Solve $\frac{3x-4}{2} \geq \frac{x+1}{4} - 1$. Show the graph of the solutions on number line.

Solution: We have $\frac{3x-4}{2} \geq \frac{x+1}{4} - 1$

$$\therefore \frac{3x-4}{2} \geq \frac{x+1-4}{4}$$

$$\therefore \frac{3x-4}{2} \geq \frac{x-3}{4}$$

$$\therefore 2(3x-4) \geq (x-3)$$

$$\therefore 6x-8 \geq x-3$$

$$\therefore 5x \geq 5$$

$$\therefore x \geq 1$$

$$x \in [1, \infty)$$

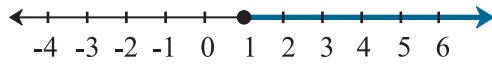

Fig. 8.8

The graph of solution is shown in Fig. 8.8

Ex. 8 : The length of a rectangle is three times the breadth. If the perimeter of the rectangle is at least 160 cm, then find the possible breadths of the rectangle.

Solution: If x cm is the breadth, then length is $3x$

$$\therefore \text{Perimeter} = 2(l + b) \geq 160$$

$$2(3x + x) \geq 160$$

$$x \geq 20$$

$$\therefore \text{breadth} \geq 20 \text{ cm}$$

EXERCISE 8.1

1. Write the inequations that represent the interval and state whether the interval is bounded or unbounded.

(i) $[-4, 7/3]$ (ii) $(0, 0.9]$ (iii) $(-\infty, \infty)$

(iv) $[5, \infty)$ (v) $(-11, -2)$ (vi) $(-\infty, 3)$

2. Solve the following inequations

(i) $3x - 36 > 0$ (ii) $7x - 25 \leq -4$

(iii) $0 < \frac{x-5}{4} < 3$ (iv) $|7x - 4| < 10$

3. Sketch the graph which represents the solution set for the following inequations.

(i) $x > 5$ (ii) $x \geq 5$

(iii) $x < 3$ (iv) $x \leq 3$

(v) $-4 < x < 3$ (vi) $-2 \leq x < 2.5$

(vii) $-3 \leq x \leq 1$ (viii) $|x| < 4$

(ix) $|x| \geq 3.5$

4. Solve the inequations.

(i) $5x + 7 > 4 - 2x$ (ii) $3x + 1 \geq 6x - 4$

(iii) $4 - 2x < 3(3 - x)$ (iv) $\frac{3}{4}x - 6 \leq x - 7$

(v) $-8 \leq -(3x - 5) < 13$

(vi) $-1 < 3 - \frac{x}{5} \leq 1$

(vii) $2|4 - 5x| \geq 9$

(viii) $|2x + 7| \leq 25$

(ix) $2|x + 3| > 1$

(x) $\frac{x+5}{x-3} < 0$

(xi) $\frac{x-2}{x+5} > 0$

- Rajiv obtained 70 and 75 marks in first two unit tests. Find the minimum marks he should get in the third test to have an average of at least 60 marks.
- To receive Grade 'A' in a course, one must obtain an average of 90 marks or more in five examinations (each of 100 marks). If Sunita's marks in first four examinations are 87, 92, 94 and 95, find minimum marks that Sunita must obtain in fifth examination to get grade 'A' in the course.
- Find all pairs of consecutive odd positive integers both of which are smaller than 10 such that their sum is more than 11.
- Find all pairs of consecutive even positive integers, both of which are larger than 5 such that their sum is less than 23.
- The longest side of a triangle is twice the shortest side and the third side is 2cm longer than the shortest side. If the perimeter of the triangle is more than 166 cm then find the minimum length of the shortest side.



Let's Learn

8.4 Graphical solution of linear inequality of two variable :

A line divides the Cartesian plane into two parts. Each part is known as a half plane. A vertical line will divide the plane in left and right half planes and a non-vertical line will divide the plane into lower and upper half planes.

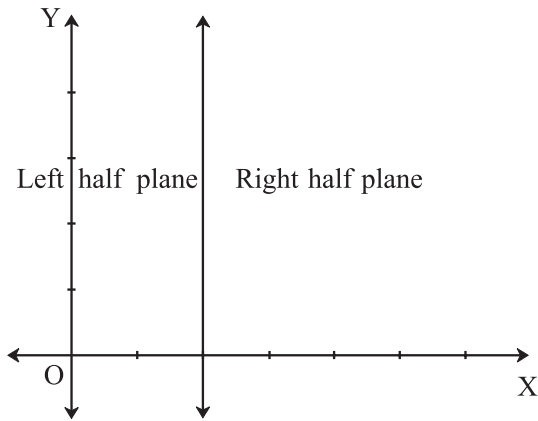

Fig. 8.9

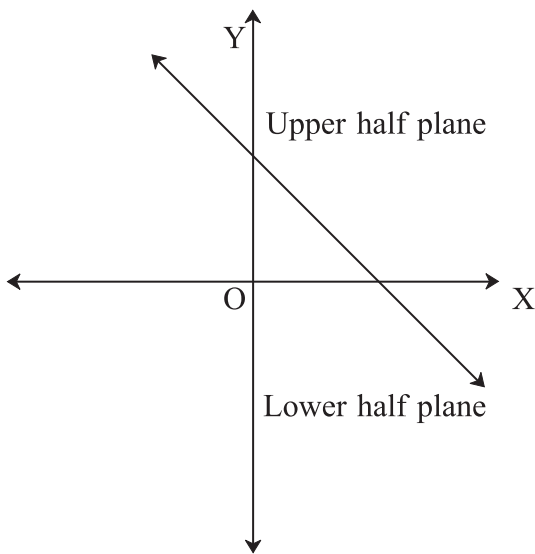

Fig. 8.10

A point in the Cartesian plane will either lie on a line or will lie in either of the half planes I or II. We shall now examine the relationship, if any, of the points in the plane and the inequalities

$$ax + by < c \text{ or } ax + by > c.$$

Let us consider the line $ax + by = c$, $a \neq 0$ and $b \neq 0$ (1)

There are three possibilities namely:

(i) $ax + by = c$ (ii) $ax + by > c$

(iii) $ax + by < c$.

In case (i), verify that all points (x, y) satisfying (1) lie on the line it represents and conversely.

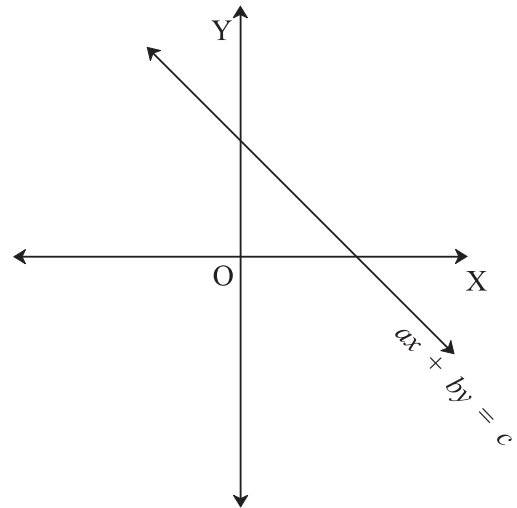

Fig. 8.11

In cases (ii) and (iii) if any point in one of half planes (say H_1 plane) satisfies the inequation then every point of that half plane (H_1 plane) satisfies the same inequation. Therefore every point of that half plane (say H_1 plane) is the solution of the inequation. Therefore H_1 half plane is the solution set of the inequation.

1. The region containing all the solutions of an inequality is called the solution region.
2. In order to identify the half plane represented by an inequality, it is just sufficient to take any point (a, b) (not on the line) and check which inequality it satisfies. If it satisfies, then the inequality represents the half plane. Colour the region which contains the point. For convenience, the point $(0, 0)$ is preferred.

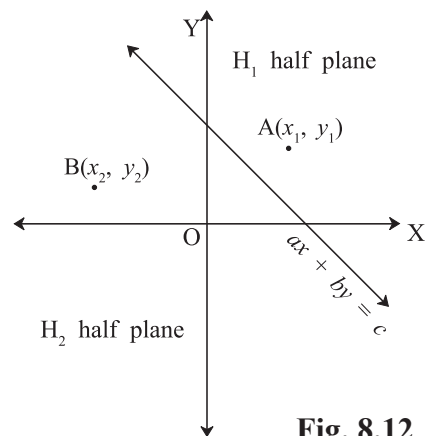

Fig. 8.12

3. If an inequality is of the type $ax + by \geq c$ or $ax + by \leq c$, then the points on the line $ax + by = c$ are also included in the solution region. So draw a dark line in the solution region.
4. If an inequality is of the form $ax + by > c$ or $ax + by < c$, then the points on the line $ax + by = c$ are not to be included in the solution region. So draw a broken or dotted line in the solution region.

**Consider linear inequalities in two variables
x and y :**

$$40x + 20y \leq 120 \dots\dots\dots (1)$$

Let us now solve this inequality keeping in mind that x and y can be only whole numbers. In this case, we find the pairs of values of x and y , which make the statement (1) true. In fact, the set of such pairs will be the solution set of the inequality (1).

To start with, let $x = 0$. Then L.H.S. of (1) is

$$40x + 20y = 120$$

$$(0) + 20y = 120.$$

Thus, we have $20y \leq 120$ or $y \leq 6 \dots\dots\dots (2)$

For $x = 0$, the corresponding values of y can be 0, 1, 2, 3, 4, 5, 6 only. In this case, the solutions of (1) are (0, 0), (0, 1), (0,2), (0,3), (0,4), (0, 5) and (0, 6). Similarly, other solutions of (1), when $x = 1, 2$ and 3 are: (1, 0), (1, 1), (1, 2), (1, 3), (1, 4), (2, 0), (2, 1), (2, 2), (3, 0)

This is shown in Fig 8.13

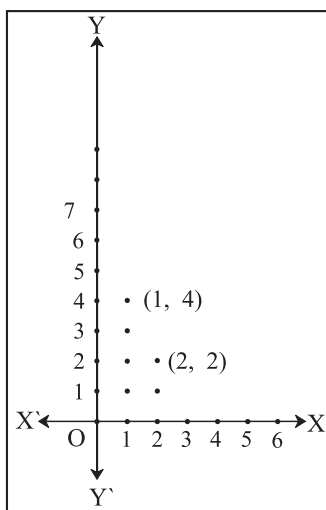

Fig. 8.13

Let us now extend the domain of x and y from whole numbers to real numbers, and see what will be the solutions of (1) in this case.

You will see that the graphical method of solution will be very convenient in this case. For this purpose, let us consider the (corresponding) equation and draw its graph.

$$40x + 20y = 120 \dots\dots\dots (3)$$

In order to draw the graph of the inequality (1), we take one point say (0, 0), in half plane I and check whether values of x and y satisfy the inequality or not.

We observe that $x = 0, y = 0$ satisfy the inequality. Thus, we say that the half plane I is the graph (Fig 8.14) of the inequality. Since the points on the line also satisfy the inequality (1) above, the line is also a part of the graph.

Thus, the graph of the given inequality is half plane I including the line itself. Clearly half plane II is not the part of the graph. Hence, solutions of inequality (1) will consist of all the points of its graph (half plane I including the line).

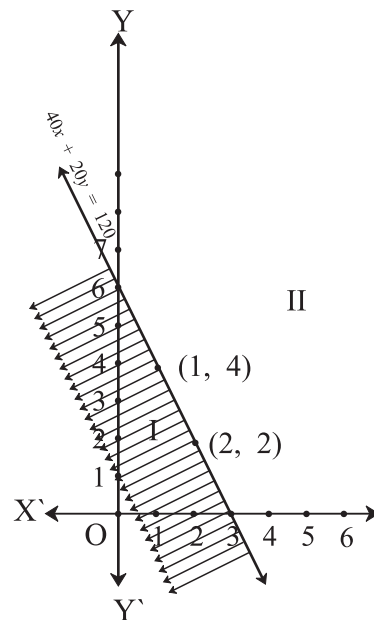

Fig. 8.14

We shall now consider some examples to explain the above procedure for solving a linear inequality involving two variables.

Ex. 11: Solve $3x - 6 \geq 0$ graphically in two dimensional plane.

Solution: Graph of $3x - 6 = 0$ is given in the Fig 8.15 We select a point, say $(0, 0)$ and substituting it in given inequality, we see that:

$3(0) - 6 \geq 0$ or $-6 \geq 0$ which is false.

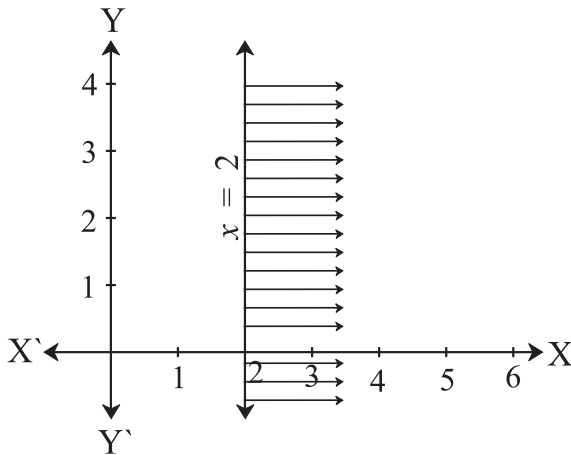

Fig. 8.15

Thus, the solution region is the shaded region on the right hand side of the line $x = 2$. Which is opposite side of point (OP)

Ex. 12: Solve $y < 2$ graphically.

Solution: Graph of $y = 2$ is given in the Fig 8.16 Let us select a point, $(0, 0)$ in lower half plane I and putting $y = 0$ in the given inequality, we see that $0 < 2$ which is true.

Thus, the solution region is the shaded region below the line $y = 2$. Hence, every point below the line (excluding all the points on the line) determines the solution of the given inequality.

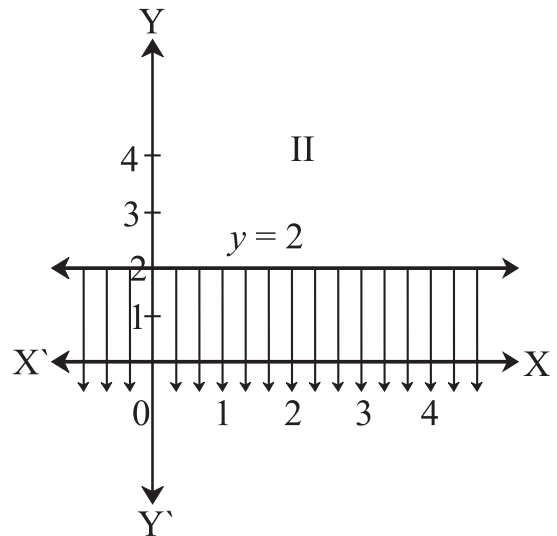

Fig. 8.16

Ex. 13: Solve $3x + 2y > 6$ graphically.

Solution: Graph of $3x + 2y = 6$ is given as dotted line in the Fig

This line divides the XY-plane in two half planes I and II. We select a point (not on the line), say $(0, 0)$, which lies in one of the half planes (Fig 8.17) and determine if this point satisfies the given inequality, we note that $3(0) + 2(0) > 6$ or $0 > 6$, which is false.

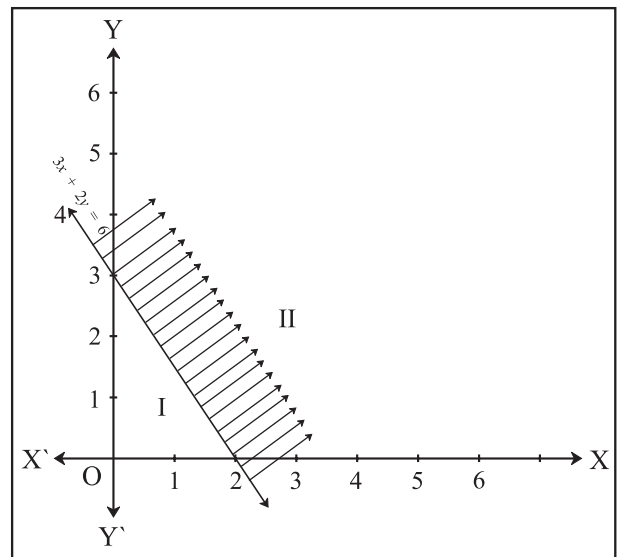

Fig. 8.17

Hence, half plane I is not the solution region of the given inequality. Clearly, any point on the

line does not satisfy the given strict inequality. In other words, the shaded half plane II excluding the points on the line is the solution region of the inequality.

EXERCISE 8.2

1. Solve the following inequations graphically in two-dimensional plane

- (i) $x \leq -4$ (ii) $y \geq 3$
- (iii) $y \leq -2x$ (iv) $y - 5x \geq 0$
- (v) $x - y \geq 0$ (vi) $2x - y \leq -2$
- (vii) $4x + 5y \leq 40$ (viii) $\frac{1}{4}x + \frac{1}{2}y \leq 1$

2. Mr. Rajesh has Rs. 1800 to spend on fruits for meeting. Grapes cost Rs. 150 per kg. and peaches cost Rs. 200 per kg. Formulate and solve it graphically.

3. Diet of sick person must contain at least 4000 units of vitamin. Each Unit of food F1 contains 200 units of vitamin, where as each unit of food F2 contains 100 units of vitamins. Write an inequation to fulfill sick person's requirements and represent the solution set graphically.



8.5 Solution of System of Linear Inequalities in Two Variables (Common solution) :

In previous Section, we have learnt how to solve linear inequality in one or two variables graphically. We will now illustrate the method for solving a system of linear inequalities in two variables graphically through some examples.

Ex. 14: Solve the following system of inequalities graphically

- $5x + 4y \leq 40$ (1)
- $x \geq 2$ (2)
- $y \geq 3$ (3)

Solution: Draw the graphs of the lines $5x + 4y = 40$, $x = 2$ and $y = 3$ Note that the inequality (1) represents shaded region below the line $5x + 4y = 40$ and inequality (2) represents the shaded region right of line $x = 2$ but inequality (3) represents the shaded region above the line $y = 3$. Hence, the points in the shaded region(Fig8.18) represent the required solutions

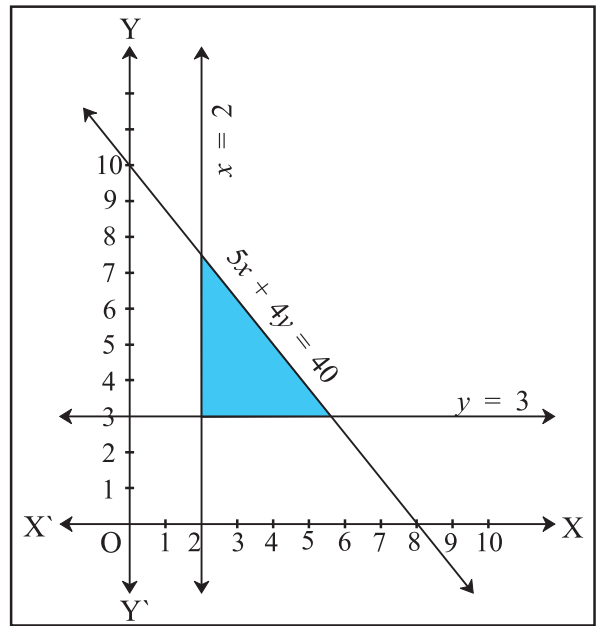

Fig. 8.18

In many practical situations involving system of inequalities, variables x and y often represent quantities that cannot have negative values; for example, number of units produced, number of articles purchased, number of hours worked, etc. Clearly, in such cases, $x \geq 0$, $y \geq 0$ and the solution region lies only in the first quadrant.

Ex. 15: Solve the following system of inequalities graphically.

- $8x + 3y \leq 100$ (1)
- $x \geq 0$ (2)
- $y \geq 0$ (3)

Solution: Draw the graph of the line $8x + 3y = 100$

The inequality $8x + 3y \leq 100$ represents the shaded region below the line, including the points on the line $8x + 3y = 100$ (Fig 8.19). Since $x \geq 0$, $y \geq 0$, all points in the shaded region, including the points on the line and the axes, represent the solution of the given system of inequalities.

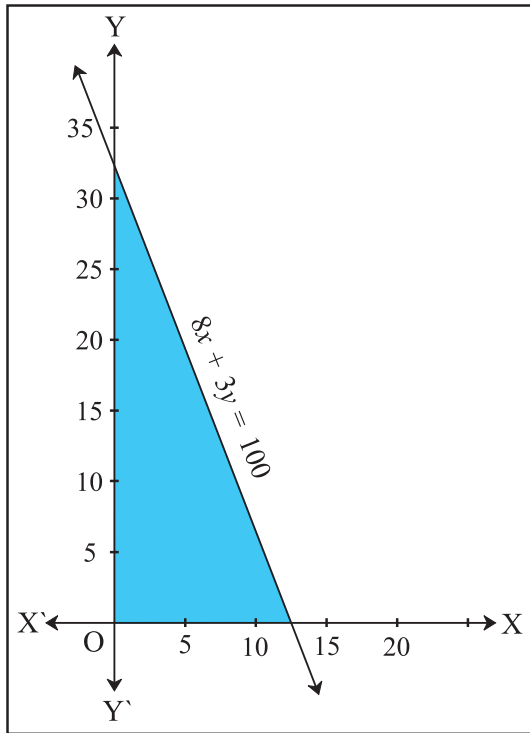

Fig. 8.19

Ex. 16: Solve the following system of inequalities graphically

$$x + 2y \leq 8 \quad \dots\dots (1)$$

$$2x + y \leq 8 \quad \dots\dots (2)$$

$$x \geq 0 \quad \dots\dots (3)$$

$$y \geq 0 \quad \dots\dots (4)$$

Solution: Draw the graphs of the lines $x + 2y = 8$ and $2x + y = 8$.

The inequalities (1) and (2) represent the region below the two lines, including the points on the respective lines. Since $x \geq 0$, $y \geq 0$, all points in the shaded region represent solutions of the given system of inequalities (Fig 8.20)

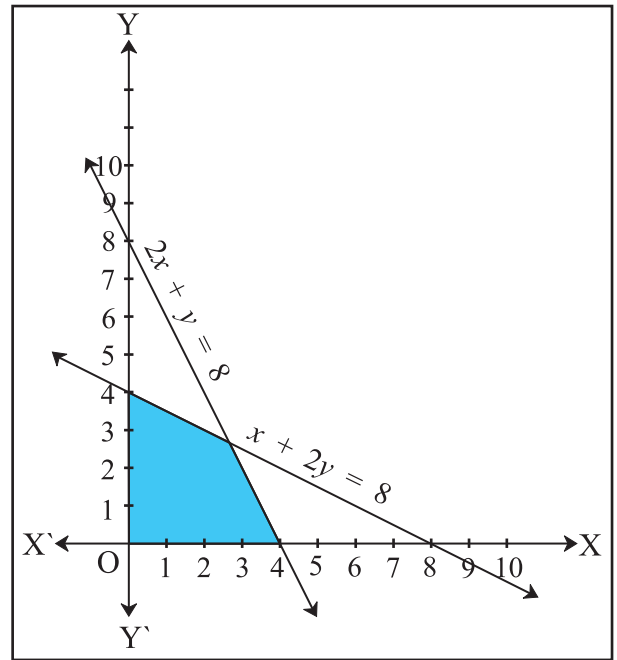

Fig. 8.20

EXERCISE 8.3

Find the graphical solution of following system of linear inequations

1. $x - y \leq 0, 2x - y \geq -2$
2. $2x + 3y \geq 12, -x + y \leq 3, x \leq 4, y \geq 3$
3. $3x + 2y \leq 1800, 2x + 7y \leq 1400,$
4. $0 \leq x \leq 350, 0 \leq y \leq 150$
5. $\frac{x}{60} + \frac{y}{90} \leq 1, \frac{x}{120} + \frac{y}{75} \leq 1, y \geq 0, x \geq 0$
6. $3x + 2y \leq 24, 3x + y \geq 15, x \geq 4$
7. $2x + y \geq 8, x + 2y \geq 10, x \geq 0, y \geq 0$



Let's Remember

Inequality or inequation :

Definition : A statement involving real numbers or two algebraic expressions and symbols '>', '<', '≤', '≥' is called an inequality or inequation.

If $a, b \in \mathbb{R}$ and $b \neq 0$ then

(i) $ab > 0$ or $\frac{a}{b} > 0$ implies a and b both have the same sign.

(ii) $ab < 0$ or $\frac{a}{b} < 0$ implies a and b both have opposite signs.

- If a is any positive real number, that is, $a > 0$, then

(i) $|x| < a$ if and only if $-a < x < a$

(ii) $|x| \leq a$ if and only if $-a \leq x \leq a$

(iii) $|x| > a$ if and only if $x < -a$ or $x > a$

(iv) $|x| \geq a$ if and only if $x \leq -a$ or $x \geq a$

MISCELLANEOUS EXERCISE - 8

Solve the following system of inequalities graphically

1. $x \geq 3, y \geq 2$
2. $3x + 2y \leq 12, x \geq 1, y \geq 2$
3. $2x + y \geq 6, 3x + 4y < 12$
4. $x + y \geq 4, 2x - y \leq 0$
5. $2x - y \geq 1, x - 2y \leq -1$
6. $x + y \leq 6, x + y \geq 4$
7. $2x + y \geq 8, x + 2y \geq 10$
8. $x + y \leq 9, y > x, x \geq 0$
9. $5x + 4y \leq 20, x \geq 1, y \geq 2$
10. $3x + 4y \leq 60, x + 3y \leq 30, x \geq 0, y \geq 0$
11. $2x + y \geq 4, x + y \leq 3, 2x - 3y \leq 6$
12. $x - 2y \leq 3, 3x + 4y \geq 12, x \geq 0, y \geq 1$

13. $4x + 3y \leq 60, y \geq 2x, x \geq 3, x, y \geq 0$

14. $3x + 2y \leq 150, x + 4y \geq 80, x \leq 15, y \geq 0, x \geq 0$

15. $x + 2y \leq 10, x + y \geq 1, x - y \leq 0, x \geq 0, y \geq 0$

Activity 8.1

Visit a supermarket, you have Rs.100, & you want to buy some biscuits packet & toffees. If each biscuit packet cost Rs.15 & each toffee costs Rs.8. How many biscuits packets & toffee can be purchased. Write it in the inequation form.

Find the different combinations of number of biscuit packets & toffees using inequality condition.

Activity 8.2

Throw a die 15 times

- a) Let x be getting prime number on upper most face Find how many times x is achieved. Write in the form of inequation.
- b) If y is getting multiple of 2, what is the possibility of y ? Draw the graph for $x < 16$ & for $y > 3$

Activity 8.3

You are Mr. X, have Rs.10000 to invest in shares. If you want to buy some shares of company X whose market price Rs.150 & some shares of company y with market price Rs.230, then how many maximum shares each you can buy? Formulate & draw the graph.



9. COMMERCIAL MATHEMATICS



Let's Study

- Percentage
- Profit and Loss
- Interest (Simple and Compound)
- Depreciation
- Partnership
- GST
- Shares and Dividends

Let's Discuss

9.1 Percentage:

Percentage is one of the most important concept in commercial arithmetic. Calculation abilities can be developed through the study of percentage. The word percentage literally means for every 100 and it is derived from the French word cent, which means hundred.

Mathematical explanation.

If a student scores 20 marks out of maximum 30 marks, his marks can be denoted as 20 out of 30 or $\frac{20}{30}$ or 66.66 percent or 66.66%



Let's Learn

Percentage is useful for comparison of two or more fractions. This can be shown with the help of following table.

Student	Full Marks	Marks Obtained
A	100	72
B	50	41
C	150	111

In the given table performance of the student cannot be judged with the help of only marks. If we calculate the marks of all the students over one common base 100, that is marks, out of 100 marks then their marks are :

Student	Full Marks	Marks Obtained
A	100	72
B	100	82
C	100	74

This represents the percentage marks of student. Now we can compare marks of three students and rank them

Rank	I	II	III
Student	B	C	A



Let's Remember

Finding percentage: Quick calculations of conversion of fraction into percentage and percentage into fraction is very important. To convert a fraction or decimal into percentage we multiply the number by 100. To convert percentage to fraction or decimal, we divide the number by 100

Always remember, a% of b is equal to b% of a

e.g. 20% of 50 = 10 and 50% of 20 = 10

∴ 20% of 50 is equal to 50% of 20

Important formulae

1. Percentage increase =

$$\frac{\text{Increase in Quantity}}{\text{Original Quantity}} \times 100$$

2. Percentage decrease = $\frac{\text{Decrease in Quantity}}{\text{Original Quantity}} \times 100$
3. To increase a number by $x\%$ multiply it by $\frac{100+x}{100}$
4. To decrease a number by $x\%$ multiply it by $\frac{100-x}{100}$
5. If A's income is $r\%$ more than B's income then B's income is less than A's income by $\frac{r}{100+r} \times 100\%$.
6. If A's income is $r\%$ less than B's income then B's income is more than A's income by $\frac{r}{100-r} \times 100\%$.
7. If price of a commodity increases by $x\%$ then to keep the expenses same the consumption must be reduced by $\frac{x}{100+x} \times 100\%$.
8. If price of a commodity decreases by $x\%$ and expenses are same, the consumption can be increased by $\frac{x}{100-x} \times 100\%$.

SOLVED EXAMPLES

- 1) After a discount of 12% a TV is available for Rs. 26,400. If the discount is 3% more, price of TV is Rs. 25,500. What is the original price of the TV?
Solution: 3% of the cost of the TV = $26400 - 25500 = 900$
 Total cost of TV = $900 \times \frac{100}{3} = 30000$
- 2) The price of sugar is increased by 20%. What should be the percentage change in the consumption of sugar so that the expenses does not increase?

Solution: Assume that the initial price = 100
 Initial consumption = 100
 Total expenditure = 10000
 New price 120
 So consumption = $\frac{10000}{120} = 83.33$
 \therefore Percentage decrease in consumption is = $100 - 83.33 = 16.67$

EXERCISE 9.1

1. Find 77% of 580 + 34% of 390.
2. 240 candidates appeared for an examination, of which 204 passed. What is the pass percentage?
3. What percent of 8.4 kg is 168 grams?
4. If the length of a rectangle is decreased by 20%, what should be the increase in the breadth of the rectangle so that the area remains the same?
5. The price of rice increased by 20%, as a result a person can have 5kg rice for Rs 600. What was the initial price of rice per kg?
6. What percent is 3% of 5%?
7. After availing two successive discounts of 20% each, Madhavi paid Rs 64 for a book. If she would have got only one discount of 20%, how much additional amount would she have paid?
8. Price of table is 40% more than price of a chair. By what percent price of chair is less than price of a table?
9. A batsman scored 92 runs which includes 4 boundaries 5 sixes. He scored other runs buy running between the wickets. What percent of his total score did he make buy running between the wickets?

9.2 Profit and Loss

Let's Discuss

Profit: Profit is earned when an article is sold for more than its cost price.

Tax is computed and dividend is paid on the basis of profit. It is the best measure of success in an enterprise.

Profit is reflected in reduction in liabilities, increase in assets, and/or increase in owners' equity. It provides resources for investing in future operations, and its absence may result in the extinction of a company.

Loss: A loss occurs when an article is sold for less than its cost price.

Profits and losses are normally expressed as a percentage of cost price.



Let's Learn

Cost Price:

The price, at which an article is purchased, is called its *cost price*, abbreviated as *C.P.*

Selling Price:

The price, at which an article is sold, is called its *selling price*, abbreviated as *S.P.*

Profit or Gain:

If *S.P.* is greater than *C.P.*, the seller is said to have a *profit* or *gain*.

Loss: If *S.P.* is less than *C.P.*, the seller is said to have incurred a *loss*.

Loss or gain is always calculated on C.P. and discount is given on MRP or marked price.



Let's Remember

1. Gain = (S.P.) - (C.P.)
2. Loss = (C.P.) - (S.P.)
3. Gain Percentage: (Gain %)

$$\text{Gain \%} = \frac{\text{Gain} \times 100}{\text{C.P.}}$$

4. Loss Percentage: (Loss %)

$$\text{Loss \%} = \frac{\text{Loss} \times 100}{\text{C.P.}}$$

5. Selling Price (S.P.) when there is Gain.

$$\text{S.P.} = \frac{100 + \text{gain \%}}{100} \times \text{C.P.}$$

6. Selling Price (S.P.) when there is Loss.

$$\text{S.P.} = \frac{100 - \text{loss \%}}{100} \times \text{C.P.}$$

7. Cost Price (C.P.) when there is Gain.

$$\text{C.P.} = \frac{100}{100 + \text{gain \%}} \times \text{S.P.}$$

Let's Understand

1. If an article is sold at a gain of 35%, then $\text{S.P.} = 135\%$ of *C.P.*
2. If an article is sold at a loss of, 35% then $\text{S.P.} = 65\%$ of *C.P.*
3. When a person sells two similar items, one at a gain of $x\%$, and the other at a loss of $x\%$, then the seller always incurs a loss given by:

$$\begin{aligned} \text{Loss \%} &= \left(\frac{\text{common loss and gain \%}}{10} \right)^2 \\ &= \left(\frac{x}{10} \right)^2 \end{aligned}$$

4. Sometimes a seller claims to sell goods at cost price. But he uses a false weight. Then he earns profit.

To find profit percent

$$= \frac{\text{Error}}{\text{True value} - \text{Error}} \times 100$$

For example, if a trader buys rice at Rs 50 per kg. And sells it at the same price. But while selling, he uses 950 gm weight instead of 1000 gm. Here gain is equal to the cost of 50gm rice.

In the above example gain %

$$= \frac{50}{1000 - 50} \times 100 = 5.26$$

Gain = 5.26%

SOLVED EXAMPLES

Ex. 1 : Determine whether there is profit or loss in following examples Find its percentage

a) If cost price is 3800 and selling price is 4560.

b) If CP is 3800 and SP is 3420

Solution: a) $CP < SP$. Profit is = $4560 - 3800$
is = 760

$$\text{Profit percent} = \frac{760}{3800} \times 100 = 20$$

Profit = 20%

b) $CP > SP$ Loss = $3800 - 3420 = 380$

$$\text{Loss percent} = \frac{380}{3800} \times 100 = 10$$

Loss = 10%

Ex. 2 : Ketan sold a mobile phone at a price of Rs. 5250 at a loss of 25%. At what price should he sell it to get a profit of 30%?

Solution:

$$CP \text{ is } = \frac{100}{75} \times 5250 = 7000$$

$$SP = \frac{130}{100} \times 7000 = 9100$$

He should sell it at Rs. 9100 to get a profit of 30%

Ex. 3 : If selling price of 30 apples is equal to the cost price of 25 apples. What is the profit or loss percentage?

Solution:

Let cost price of one apple Rs 1

CP of 30 apples = Rs. 30

CP of 25 apples = Rs. 25

SP of 30 apples = CP of 25 apples

i.e. $SP = \frac{5}{6} CP$ i.e. $CP > SP$

$30 CP - 30 SP$

$30 - 25 = 5$ Loss

($30 SP = 25 CP$) given

$$\text{Loss percent} = \frac{5}{30} \times 100 = 16\frac{2}{3}$$

$$\text{Loss} = 16\frac{2}{3} \%$$

Ex. 4 : In a toy shop a doll was sold for Rs. 27.50 with a profit of 10%. If it was sold for Rs. 25.75 then what would have been the percentage of profit or loss ?

Solution: $SP = \text{Rs. } 27.50$

Profit = 10 %

$$CP = \frac{100}{110} \times 27.50 = 25$$

when $SP = 25.75$, profit = $25.75 - 25 = 0.75$

$$\text{Profit \%} = \frac{0.75}{25} \times 100 = 3$$

Profit = 3%

Ex. 5 : The price of a television set passing through distributor, wholesaler and retailer rises on a whole by 51.8%. If distributor and wholesaler earned 10% and 15% respectively. what is the percentage profit owned by the retailer ?

Solution: Let the original price of television be Rs. p and let the profit earned by the retailer be x .

Then $(100 + x) \%$ of 115% of 110% of $p = 151.8\%$ of p

$$\therefore \frac{100 + x}{100} \times \frac{115}{100} \times \frac{110}{100} \times p = 151.8/100 \times p$$

$$\therefore 100 + x = \frac{151.8 \times 100 \times 100}{115 \times 110} = 120$$

$\therefore x = 20$ Retailer earned 20 %.

EXERCISE 9.2

- 1) Mr. Sarad purchased a laptop for Rs. 24000 and sold it for Rs. 30000. What was the profit percentage?
- 2) Shradha purchase mobile phone and refrigerator for Rs. 18000 and 15,000 respectively. She sold the refrigerator at a loss of 20% and mobile at a profit of 20%. What is her overall profit or loss ?
- 3) A vendor bought toffees at 6 for Rs.10. How many for Rs.10 must he sell to gain 20% ?
- 4) The percentage profit earned by selling an article for Rs. 2880 is equal to the percentage loss incurred by selling the same article for Rs. 1920. At what price the article should be sold to earn 25% profit?
- 5) A cloth merchant advertises for selling cloth at 4% loss. By using faulty meter scale, he is earning profit of 20%. What is the actual length of the scale?
- 6) Sunil sells his bike worth Rs. 25000 to Rohit at a profit of 20%. After 6 months Rohit sells the bike back to Sunil at a loss of 20%. Find the total profit percent of Sunil considering both the transactions.
- 7) By selling a book at Rs. 405 bookseller incurs a loss of 25%. Find the cost price of the book.
- 8) A cloth costs Rs. 675. If it is sold at a loss of 20%, what is its cost price as a percentage of its selling price ?
- 9) Ashwin buys an article for Rs. 500. He marks it for sale at 75% more than the cost price. He offers 25% discount on marked price to his customer. Calculate the actual percentage of profit made by Ashwin.
- 10) The combined cost price of a refrigerator and a mixture is Rs. 12400. If the refrigerator costs 600% more than the mixer, find the cost price of the mixture.
- 11) Find the single discount equivalent to the discount series of 5%, 7% and 9%.
- 12) The printed price of a shirt is Rs. 390. Lokesh pays Rs. 175.50 for it after getting two successive discounts. If the first discount is 10%, find the second discount.
- 13) Amar, a manufacturer, gives a discount of Rs. 25% on the list price to his distributor Akbar, Akbar sales at 10% discount on the list price to his customer Anthony. Anthony paid Rs 540 for the article. What is profit percentage of Akbar on his cost price ?
- 14) A man sells an article at a profit of 25%. If he had bought it at 10% less and sold it for Rs 7 less, he would have gained 35%. Find cost price of the article.
- 15) Mr Mehta sold his two luxury cars at Rs. 39,10,000 each. On one he gains 15% but on the other he loses 15%. How much does he gain or lose in the whole transaction ?

9.3 Interest: Simple and Compound Interest Definition of Interest:

1. Interest is defined as the cost of borrowing money. Interest is charged on the loan balance. And it is specified as an amount per cent per annum (pcpa)
2. Interest is fee paid for the use of another party's money.

To the borrower it is the cost of renting money.

To the lender it is the income from the lending money.

Interest can also be the rate paid for money on deposit.

Interest is calculated in two ways:

Simple interest and Compound interest

Simple interest: Interest calculated only on the principal or original amount of loan.

Compound interest: Interest calculated on the principal amount and also on the accumulated interest of previous years.

The difference between simple interest and compound interest will be clear from the following example.

A sum of Rs 1000 at 10% per annum have

Simple interest	Period	Compound interest
Rs 100	1st year	Rs 100
Rs 100	2nd year	Rs 110
Rs 100	3rd year	Rs 121
Rs 100	4th year	Rs 133

Note that the previous year's interest are added to the original sum of Rs. 100 to calculate the compound interest.

Important terms :

Creditor : The person who lends money.

Debtor : The person who borrows money.

Principal / capital : The amount of money which is borrowed or deposited.

Time : The period for which money is deposited or borrowed is called time.

Amount : The sum of the principal and interest at the end of time is called amount.

Amount = principal + interest

Interest rate: The interest of one year for every Rs. 100 is called interest rate per annum.

How to calculate interest ?

Case 1. Simple interest:

Suppose P = principal

n = number of years

r = rate of interest p.a.

N = number of periods for compounding

R = rate of interest per compounding period.

I = interest, A = amount

$$\text{Then } I = \frac{P \cdot n \cdot r}{100}$$

$$A = P + \frac{P \cdot n \cdot r}{100} = P \left(1 + \frac{nr}{100} \right)$$

Case 2: compound interest

$$A = P \left(1 + \frac{r}{100} \right)^n$$

Special cases:

1. When compound interest is calculated half yearly.

Here rate (R) = $\frac{r}{2}$ % and time (N) = 2n

$$A = \left(1 + \frac{\frac{r}{2}}{100} \right)^{2n}$$

2. When compound interest is calculated quarterly.

Here rate (R) = $\frac{r}{4}$ % and time (N) = 4n

$$A = \left(1 + \frac{\frac{r}{4}}{100} \right)^{4n}$$

3. The difference between compound interest and simple interest over 2 years is given by

$$\frac{pr^2}{100^2}$$

case 3. When interest is compounded annually

but time is in fraction. If time is $4\frac{2}{5}$ years,

$$\text{Then amount (A)} = P \left[1 + \frac{R}{100} \right]^4 \times \left[1 + \frac{\frac{2}{5}R}{100} \right]$$

Case 4. When rates are different for different years. If rates are $R_1\%$, $R_2\%$ and $R_3\%$ for first, second and third years respectively.

$$\text{Then amount (A)} = P \left[1 + \frac{R_1}{100} \right] \left[1 + \frac{R_2}{100} \right] \left[1 + \frac{R_3}{100} \right]$$

SOLVED EXAMPLES

- 1) The simple interest on a sum of money is 36% of the principal and the rate per annum

is equal to the number of years. Find the rate percent

Solution: let principal = 100

Interest = 36

$$I = \frac{P N R}{100}$$

$$36 = \frac{100 N R}{100}$$

$$36 = RN$$

Since $R = N$, $R = 6$, $N = 6$.

- 2) The rate of interest for the first 2 years is 6% per annum, for next 3 years 7% per annum and for the period beyond five years 8% per annum. If a man lent out Rs. 1500 for 9 years, find the total interest earned by him.

Solution: Interest for first two years will be equal to $6 \times 2 = 12\%$

Interest for next 3 years will be $3 \times 7 = 21\%$

Interest for next 4 years will be $4 \times 8 = 32\%$

Total interest = $12 + 21 + 32 = 65\%$

$$\text{Interest Earned} = \frac{1500 \times 65}{100} = 975$$

- 3) A certain sum of money amounts to Rs. 10,440 in 2 years and Rs. 12,600 in 5 years. Find the principal and the rate of simple interest.

Solution: Principal + interest for 5 years

– (Principal + interest for 2 years)

= 0 + interest for 3 years

$12600 - 10440 =$ interest for 3 years

$2160 =$ interest for 3 years

1 years interest = 720

2 years interest = 1440

Principal = $10440 - 1440 = 9000$

$r = I \times 100 / P \times n$

Rate of interest = $\frac{720 \times 100}{9000 \times 1} = 8\%$ per annum

Principal = 9000, rate = 8% per annum

SOLVED EXAMPLES

- 1) How much will be the compound interest on Rs. 8000 after 3 years at the rate of 5% per annum.

$$\text{Solution: } A = P \left(1 + \frac{R}{100}\right)^N = 8000 \left(1 + \frac{5}{100}\right)^3$$

$$= 8000 \times \frac{105}{100} \times \frac{105}{100} \times \frac{105}{100}$$

$$= 21 \times 21 \times 21 = 9261$$

$$I = A - P = 9261 - 8000 = 1261$$

- 2) Find the compound interest on Rs. 10000 at 8% per annum for 2 years 6 months compounded annually.

Solution: $P = 10000$

$$n = 2.5 = \frac{5}{2}$$

$R = 8\%$ per annum

$n = 2$ years and half year

$$A = P \left(1 + \frac{R}{100}\right)^N = 100 \left(1 + \frac{8}{100}\right)^2 \left(1 + \frac{4}{100}\right)$$

$$= 12130.56$$

$$\text{Interest} = A - P = 12130.56 - 10000 = 2130.56$$

- 3) The compound interest on a certain sum for 2 years at 10% per annum is Rs. 1050. Find the principal.

$$A = P \left(1 + \frac{R}{100}\right)^N$$

$$\therefore P + 1050 = P \left(1 + \frac{10}{100}\right)^2$$

$$1050 = \left(p \times \frac{110}{100} \times \frac{110}{100}\right) - p = p \left(\frac{21}{100}\right)$$

$$\frac{1050 \times 100}{100} = p = 5000$$

Principal = 5000

EXERCISE 9.3

- 1) What would be the simple interest on an amount of Rs. 9600 at the rate of 6% per annum after 3 years?
- 2) What would be the simple interest at the rate of $9\frac{1}{2}$ % per annum on Rs. 6000 for $2\frac{1}{2}$ years?
- 3) What would be the simple interest on Rs. 8400 in 9 months at the rate of 8.25 percent per annum?
- 4) What would be the compound interest on Rs 4200 for 18 months at 10% per annum compounded half yearly?
- 5) Find compound interest on Rs.10000 for 2 years at 8% per annum compounded half yearly.
- 6) In how many years Rs. 1,00,000 will become Rs. 1,33,100 at compound interest rate of 10% per annum?
- 7) A certain sum of money becomes three times of itself in 20 years at simple interest. In how many years does it become double of itself at the same rate of simple interest ?
- 8) A person borrows 10000 for 2 years at 4% p a simple interest he immediately lends it to another person at 6.5 % p. a. for 2 years. Find his total gain in the transaction.
- 9) A man deposits Rs 200 at the end of each year in recurring account at 5% compound interest. How much will it become at the end of 3 years?
- 10) A man gets a simple interest of Rs. 2,000 on a certain principal at the rate of 5% p.a. in 4

years. What compound interest will the man get on twice the principal in 2 years at the same rate.

- 11) The difference between simple interest and compound interest on a certain sum of money is Rs.32 at 8% per annum for 2 years. Find the amount.

9.4 Depreciation

Definition of Depreciation : The monetary value of an asset decreases over time due to use, wear and tear or obsolescence. This decrease is called depreciation. Machinery, equipment, furniture, vehicles are some examples of assets that are likely to depreciate over a specific period of time. We can find out present value of asset, when rate of depreciation is given, by using following formula.

- 1) Present value of Asset = $V \left(1 - \frac{r}{100}\right)^n$
- 2) Value of Asset n years ago = $V \div \left(1 - \frac{r}{100}\right)^n$

Where V = Initial value of Asset, r = rate of depreciation, n = number of years.

SOLVED EXAMPLES

Ex. 1 : An engineering firm purchased some equipments at Rs. 10,935. Rate of depreciation is $11\frac{1}{9}$. Find the value of the equipments after 3 years.

Solution :

Present value of equipments = 10935

Rate of depreciation = $11\frac{1}{9} = \frac{100}{9}$

Value after 3 years = $V \left(1 - \frac{r}{100}\right)^n$

$$\begin{aligned}
&= 10935 \left(1 - \frac{100/9}{100}\right)^3 \\
&= 10935 \times \left(1 - \frac{800}{900}\right)^3 \\
&= 10935 \times \frac{8}{9} \times \frac{8}{9} \times \frac{8}{9} \\
&= 15 \times 8 \times 8 \times 8 \\
&= 7680
\end{aligned}$$

∴ Value of the equipments after 3 years
= Rs. 7680

Ex. 2 Depreciated value of a machine after 2 years is Rs. 8464. Rate of Depreciation is 8%. Find present value of the machine.

Solution :

Value of the machine after 2 years = Rs. 8464

Rate of depreciation = 8%

Let present value of the machine = V

$$\begin{aligned}
\therefore \text{Rs. } 8464 &= V \left(1 - \frac{8}{100}\right)^2 \\
&= V \left(\frac{92}{100}\right)^2
\end{aligned}$$

$$\therefore \frac{8464 \times 100 \times 100}{92 \times 92} = V$$

$$\therefore \frac{8464 \times 25 \times 25}{23 \times 23} = V$$

$$16 \times 25 \times 25 = V$$

$$V = 10,000$$

∴ Present value of the machine = Rs. 10,000

Ex. 3 : The value of a machine depreciates from Rs. 23625 to Rs. 15379 in 3 years. What is the rate of depreciation?

Solution :

$$\text{Rs. } 15379 = \text{Rs. } 23625 \left(1 - \frac{r}{100}\right)^3$$

$$15379 = 23625 \left(\frac{100-r}{100}\right)^3$$

$$\frac{15379}{23625} = \left(\frac{100-r}{100}\right)^3$$

Divide numerator and denominator by 7

$$\frac{15379/7}{23625/7} = \frac{2197}{3375} = \left(\frac{13}{15}\right)^3 = \left(\frac{100-r}{100}\right)^3$$

$$\therefore \frac{13}{15} = \frac{100-r}{100}$$

$$\therefore 1300 = 1500 - 15r$$

$$15r = 200$$

$$r = \frac{200}{15}$$

$$= 13.33$$

∴ rate of depreciation = 13.33

Ex. 4 : Mr. Sharma purchased a car for Rs. 10,00,000/-. He sold his car at depreciated value, Rs. 6,81,472/-. Rate of depreciation is 12%. Find after how many years he sold his car ?

Solution :

Purchase price of the car Rs. 10,00,000/-

Value of the car after depreciation = Rs. 6,81,472/-

Rate of depreciation = 12%

$$\therefore 6,81,472 = 10,00,000 \left(1 - \frac{12}{100}\right)^n$$

$$\frac{681472}{1000000} = \left(\frac{88}{100}\right)^n$$

$$\frac{88 \times 88 \times 88}{100 \times 100 \times 100} = \left(\frac{88}{100}\right)^n$$

$$\therefore \left(\frac{88}{100}\right)^3 = \left(\frac{88}{100}\right)^n$$

$$\therefore n = 3$$

EXERCISE 9.4

- 1) Kanchan purchased a Maruti car for Rs.2,45,000/- and the rate of depreciation is $14\frac{2}{7}$ % per annum. Find the value of the car after two years?
- 2) The value of a machine depreciates from Rs.32768 to Rs.21,952/- in three years. What is the rate of depreciation ?
- 3) The value of machine depreciates at the rate of 10% every year. It was purchased 3 years ago. Its present value is Rs.2,18,700/-. What was the purchase price of the machine ?
- 4) Mr. Manish purchased a motorcycle at Rs.70,000/-. After some years he sold his motorcycle at exact depreciated value of it that is Rs.51,030/-. Rate of depreciation was taken as 10%. Find after how many years he sold his motorcycle.
- 5) Mr. Chetan purchased furniture for her home at Rs.5,12,000/-. Considering rate of depreciation as 12.5%, what will be value of furniture after 3 years.
- 6) Grace Fashion Boutique purchased a sewing machine at Rs.25,000/-. After 3 years machine was sold at depreciated value Rs.18,225/- Find rate of depreciation.
- 7) Mr. Pritesh reduced value of his assets by 5% each year, which were purchased for Rs.50,00,000/-. Find the value of assets after 2 years.
- 8) A manufacturing company is allowed to charge 10% depreciation on its stock. Initial value of the stock was Rs.60,000/-. After how many years value of the stock will be 39366?

9.5 Partnership

Let's Discuss

Partnership: When two or more than two persons run a business jointly, they are called partners and the deal is known as partnership.

Types of Partners:

Working Partner: A partner who invests money and manages the business as well.

Sleeping Partner: A partner who simply invests the money but not involved in day today affairs of business.

Division of Profit/Loss:

- i) When investments of all partners are for the same time but different in amount, the profit or loss is distributed among the partners in the ratio of their amount of investments. Suppose A and B invest Rs X and Rs. Y respectively for a year in a business, then at the end of the year,
(A's share of profit) : (B's share of profit)
= X : Y
- ii) When investments of all partners are for the different time periods but same in amount, the profit or loss is distributed in the ratio of the time period they have invested for. Suppose A and B invest Rs. X each. But after 6 months A withdraw his capital and B continues the same business for a year, then at the end of the year
(A's share of profit) : (B's share of profit)
= 6 months : 12 months = 1 : 2
- iii) When investments are different in amount and for different time periods. Then profit or loss is distributed in the ratio of (Capital × period). Suppose A invests Rs X for P months and B invests Rs. Y for 9 months then
(A's share of profit) : (B's share of profit)
= xp : yq

SOLVED EXAMPLES

Ex.1 : Kajal and Kiran invest in a business in the ratio 10 : 9. If 5% of the total profit goes to charity and Kajal's share is Rs. 2000, what is the total profit ?

Solution: Let the total profit be Rs. 100.

After paying to charity, Kajal's share

$$= \left(95 \times \frac{10}{19} \right) = \text{Rs. } 50$$

If Kajal's share is Rs. 50, total profit

= Rs. 100.

If Kajal's share is Rs. 2000, total profit

$$= \left(\frac{100}{50} \times 2000 \right) = 4000.$$

Ex.2 : John, Jani, Janardan started a business with their investments in the ratio 1: 3 :5. After 6 months, John invested the same amount as before and Jani as well as Janardan withdrew half of their investments. Find the ratio of their profits at the end of the year .Let their initial investments be x, 3x and 5x respectively. Then, their ration of investment

	A	B	C
For 1 st 6 months	x	3x	5x
For next 6 months	+2x	+1.5x	+2.5x
Total	3x	4.5x	7.5x

$$\therefore \text{ratio} = 3 : 4.5 : 7.5 \text{ or } 2 : 3 : 5$$

Ex.3: Akshay is a working and Bhushan is sleeping partner in a business. Akshay puts in Rs. 15,000 and Bhushan puts in Rs.20,000. Akshay receives 30% of the profit for managing the business and the rest is divided in proportion to their capital. What does each get out of a profit of Rs. 100000?

Solution : Total profit = Rs. 1,00,000

Akshay's share for managing the business

$$\text{i.e. } \frac{30}{100} \times 1,00,000 = 30,000$$

Remaining profit of Akshay and Bhushan as per their capital = 1,00,000 – 30,000 = 70,000

Ratio of amounts = 15,000 : 20,000 i.e.3 : 4

Sum of ratios = 3 + 4 = 7

Akshay's share =30,000+30,000 = 60,000

Bhushan's share = 40,000

Ex.4: If 4 (A's capital) = 6 (B's capital) = 10 (C's capital), then out of a profit of Rs. 7750, What is C's share?Answer:

Let 4A = 6B = 10C = k. Then, A = k/4, B = k/6, and C =k/10 .

$$A : B : C = \frac{k}{4} : \frac{k}{6} : \frac{k}{10} = 15 : 10 : 6.$$

Hence, C's share $(7750 \times \frac{6}{31}) = \text{Rs. } 1500.$

Ex.5: Seeta started a business by investing Rs.50,000/-. After six months, Geeta joined her with a capital of Rs.80,000/-. After 3 years, they earned a profit of Rs.24,500/-. What was Seeta's share in the profit ?

Solution:

Seeta's investment is for 36 months , Geeta's investment is for 30 months

$$\text{Seeta : Geeta} = (50000 \times 36) : (80000 \times 30) = 3 : 4.$$

$$\begin{aligned} \text{Seeta's share} &= \text{Rs. } \left(24500 \times \frac{3}{7} \right) \\ &= \text{Rs. } 10500. \end{aligned}$$

EXERCISE 9.5

- 1) Three partners shared the profit in a business in the ratio 5 : 6 :7 . They had partnered for 12 months, 10 months and 8 months respectively. What was the ratio of their investments?

- 2) Kamala, Vimala and Pramila enter into a partnership. They invest Rs. 40,000, Rs. 80,000 and Rs. 1,20,000 respectively. At the end of the first year, Vimala withdraws Rs. 40,000, while at the end of the second year, Pramila withdraws Rs. 80,000. In what ratio will the profit be shared at the end of 3 years ?
- 3) Sanjeev started a business investing Rs.25,000 in 1999. In 2000, he invested an additional amount of Rs. 10,000 and Rajeev joined him with an amount of Rs. 35,000. In 2001, Sanjeev invested another additional amount of Rs.10,000 and Pawan joined them with an amount of Rs.35,000. What will be Rajeev's share in the profit of Rs.1,50,000 earned at the end of 3 years from the start of the business in 1999?
- 4) Teena, Leena and Meena invest in a partnership in the ratio: $7/2, 4/3, 6/5$. After 4 months, Teena increases her share 50%. If the total profit at the end of one year is Rs.21,600, then what is Leena's share in the profit?
- 5) Dilip and Pradeep invested amounts in the ratio 2:1, whereas the ratio between amounts invested by Dilip and Sudip was 3:2. If Rs. 1,49,500 was their profit, how much amount did Sudip receive ?
- 6) The ratio of investments of two partners Jatin and Lalit is 11:12 and the ratio of their profits is 2 : 3. If Jatin invested the money for 8 months, find for how much time Lalit invested his money.
- 7) Three friends had dinner at a restaurant. $\frac{2}{3}$
When the bill was received, Alpana paid as much as Beena paid and Beena paid $\frac{1}{2}$ as much as Catherin paid. What fraction of the bill did Beena pay ?
- 8) Roy start a business with Rs. 10000, Shikha joins him after 2 month with 20% more investment than Roy, after 2 month Tariq joins him with 40% less than Shikha. If the profit earned by them at the end of the year is equal to the twice of the difference between investment of Roy and ten times the investment of Tariq. Find the profit of Roy?
- 9) If $4(P's\ Capital) = 6(Q's\ Capital) = 10(R's\ Capital)$, then out of the total profit of Rs 5580, what is R's share?
- 10) A and B start a business, with A investing the total capital of Rs.50000, on the condition that B pays A interest at the rate of 10% per annum on his half of the capital. A is a working partner and receives Rs.1500 per month from the total profit and any profit remaining is equally shared by both of them. At the end of the year, it was found that the income of A is twice that of B. Find the total profit for the year?

9.6 GST (Goods and Service Tax)



Let's Recall

We have studied GST in 10th standard. We will revise this topic again as this is important in day to day life.

The Central government passed four sets of GST Acts in the Budget session 2017. These were Central GST Act, 2017; Integrated GST Act, 2017; Union Territory GST Act, 2017 and GST (Compensation to States) Act, 2017.



Let's Learn

What is GST?

GST is a comprehensive indirect tax levied on manufacture, sale and consumption of goods as well as services at the national level. It has replaced all indirect taxes levied on goods and services by

state and Central Governments. Businesses are required to obtain a GST Identification Number in every state they are registered.

Why is GST needed in India?

Introduction of GST is considered to be a significant step in the reform of indirect taxation in India. Amalgamating of various Central and State taxes into a single tax would help avoid the double taxation, a multiplicity of taxes, classification issues, taxable event, etc., and would lead to a common national market.

VAT rates and regulations differ from state to state. On the other hand, GST brings in uniform tax system across all the states. Here, the taxes would be divided between the Central and State government.

Impact of GST on Indian Economy

Create common national market for India, giving a boost to Foreign investment and “Make in India” campaign

Encouraging export and manufacturing activity and leading to substantive economic growth

Uniform SGST and IGST rates to reduce tax default rate.

Impact of GST on Consumers

Simpler Tax system

Reduction in prices of goods & services due to elimination of repeated taxes

Uniform prices throughout the country

Transparency in taxation system

Increase in employment opportunities

Impact of GST on Traders

Reduction in multiplicity of taxes

Reducing double taxation through input tax credit

More efficient neutralisation of taxes especially for exports

Development of common national market

Simpler tax rules

Fewer rates and exemptions

Distinction between Goods & Services no longer required

What are the Different Types of GST?

In India, there are 4 components of GST. The following table explains the 4 types of GST

	Central GST – CGST	State GST – SGST	Union territory GST – UTGST	Integr-ated GST - IGST
Tax Levied By	Central Govern-ment	State Govern-ment	Union territory Govern-ment	Combined levy, collected by Central Govern-ment



The rates and types of GST are prescribed by Govt. Rates of GST are different for different products such as 0%,5%,12%,18%.28%. We have seen this in 10th standard.

GSTIN – Goods and Service Tax Identification Number.- dealers identification number.

HSN – Harmonized System of Nomenclature. - Goods are classified with HSN code

HSN code has been adopted by more than 200 countries. HSN code has been considered as a best logical tracking system for identification and classification of Goods. India has developed its own HSN code

Is HSN code is compulsory for all the traders?

HSN code is compulsory for all, except with a turnover less than 1.5 cr. in a financial year.

Other dealers have to follow the 3 HSN structure given below.

- 2 digit HSN code for an aggregate turnover above 1.5 cr. And less than 5 cr.
- 4 digit HSN code for aggregate turnover above 5 cr.
- 8 digit HSN code for importer and exporter.

SAC- Service Accounting Code – Services are classified with SAC code

ITC – Input Tax Credit- At the time of paying

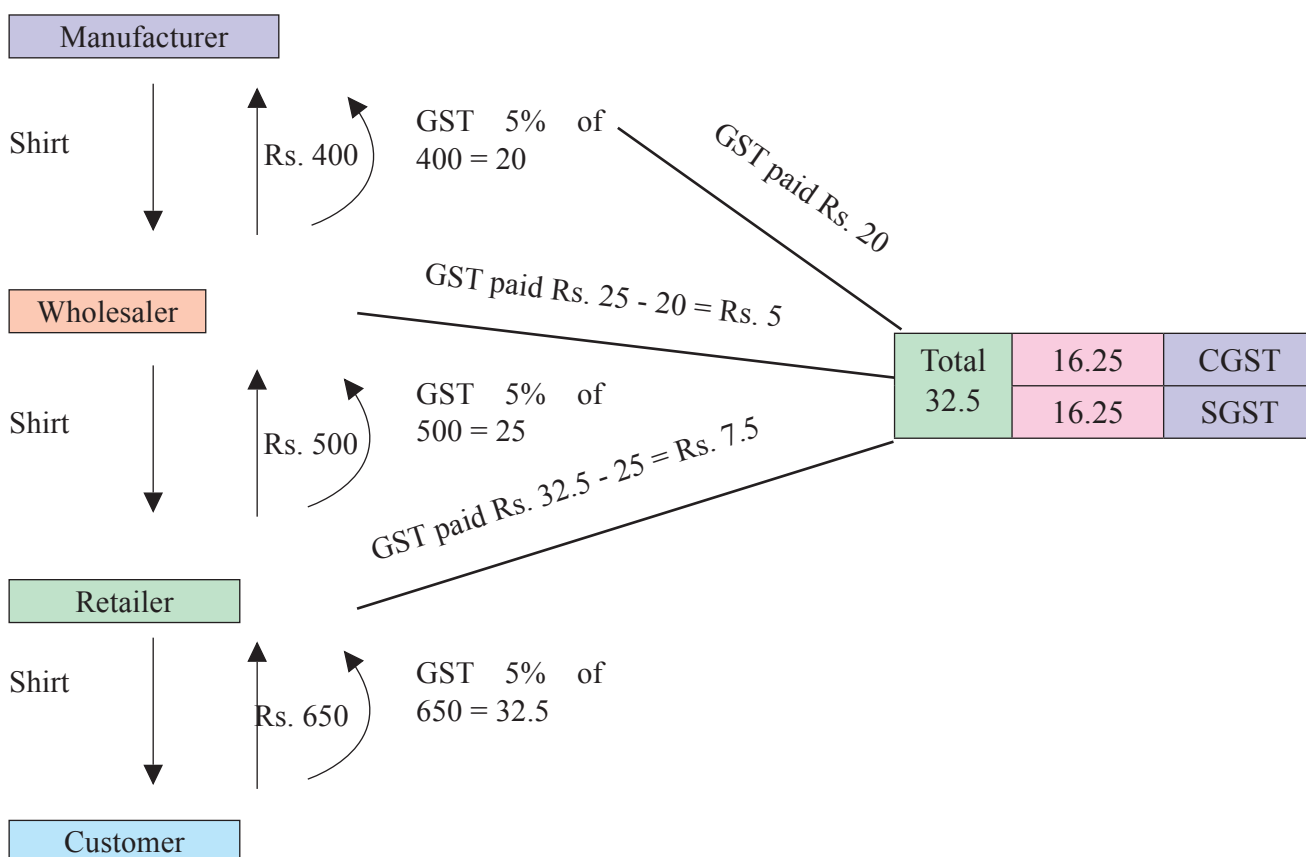

GST to the government Input Tax is deducted from Output Tax. This deduction is called ITC. Output Tax – GST collected at the time of sale.

Who is covered by GST?

All the businesses except agriculture and having aggregate turnover above Rs. 20 lakh in a financial year are liable to pay GST.

For NRI doing business in India, it is mandatory to register under GST irrespective of the turnover of his business.

Who is exempted by GST?

Essential commodities like food grain, fruits, vegetables, milk, salt etc. and services like charitable trust activities, transport of water, agriculture related services, education and health care services etc.

Example :

On garments costing less than Rs.1000. GST is applicable @ 5%

What is Input Tax Credit (ITC)

When trader pays GST at the time of purchase, it is called 'Input tax' and he collects GST at the time of sale which is called 'Output tax'. At the time of paying GST to the government a trader deducts the 'Input Tax' from the Output tax and pays the remaining tax. This deduction of input tax is called input tax credit.

$$\text{GST Payable} = \text{Output Tax} - \text{ITC}$$

Example: 2 (Comprehensive Comparison)

Comparison between Multiple Indirect tax and GST

Particulars (Rs.)	without GST	With GST
Manufacture to Wholesaler		
Cost of Production	5,000.00	5,000.00
Add: Profit Margin	2,000.00	2,000.00
Manufacturer Price	7,000.00	7,000.00
Add: Excise Duty at the rate of 12%	840.00	–
Total Value (a)	7,840.00	7,000.00
Add: VAT at the rate of 12.5%	980.00	–
Add: CGST at the rate of 12%	–	840.00
Add: SGST at the rate of 12%	--	840.00
Invoice Value	8,820.00	8,680.00
Wholesaler to Retailer		
COG to Wholesaler (a)	7,840.00	7,000.00
Add: Profit Margin at the rate of 10%	784.00	700.00
Total Value (b)	8,624.00	7,700.00
Add: VAT at the rate of 12.5%	1,078.00	–
Add: CGST at the rate of 12%	–	924.00
Add: SGST at the rate of 12%	–	924.00
Invoice Value	9,702.00	9,548.00
Retailer to Consumer:		
COG to Retailer (b)	8,624.00	7,700.00
Add: Profit Margin at the rate of 10%	862.40	770.00
Total Value(c)	9,486.40	8,470.00
Add: VAT at the		

rate of 12.5%	1,185.80	–
Add: CGST at the rate of 12%	–	1,016.40
Add: SGST at the rate of 12%	–	1,016.40
Total Price to the Final consumer	10,672.20	10,502.80
Cost saving to consumer	–	169.40
% Cost Saving	–	1.59

Let's Note:

The total price to the final customer is lesser under GST.

SOLVED EXAMPLES

Ex. 1 : Shreyas caterer charged Rs.30,000 (for 100 people @ 300 each) for a family function. 5% GST is applicable to him. Find the amount of CGST & SGST & amounts payable by the customer.

Solution :

Bill Amount : Rs.30,000

Rate of GST = 5%

∴ Rate of CGST 2.5% and Rate of SGST 2.5%

$$\text{CGST \& SGST} = 30000 \times \frac{2.5}{100} = \text{Rs.750}$$

Amount payable by the customer

$$= 30000 + 750 + 750 = \text{Rs.31500}$$

Ex. 2 : “Darshana Auto Components” is selling Automobile spare parts. The firm purchased spare parts worth Rs.8,000 from wholesaler and sold it to customer for Rs.10,000. Rate of GST is 28%. Find

- Input Tax and Output Tax
- What amount of bill the company paid at the time of purchase
- Hence find the payable CGST and SGST

Solution :

- i) Input Tax = 28% of 8000
 $= \frac{28}{100} \times 8000 = \text{Rs. } 2240$
Output Tax = 28% of 10000
 $= \frac{28}{100} \times 10000 = \text{Rs. } 2800$
- ii) Total Bill Amount = 8000 + 2240
 $= 10240$
- iii) GST Payable = Output Tax – ICT
 $= 2800 - 2240$
 $= \text{Rs. } 560$
CGST = SGST = Rs.280/-

Ex. 3 : Payal bought a Laptop with 15 % discount on printed price. The printed price of laptop was Rs. 60000. 18% of GST was charged on discounted price. Find the amount of CGST and SGST. What amount did Payal pay ?

Solution :

- Discount = 15% of Rs.60000 = Rs. 9000
Tax payable value of Laptop
 $= \text{Rs. } 60000 - \text{Rs. } 9000 = \text{Rs. } 51000$
Rate of GST = 18% (given)
Rate of CGST = 9%
CGST = 9% of 51000 = Rs. 4590
SGST = Rs. 4590
- Amount Paid = 51000 + 4590 + 4590 = 60180

Ex. 4 : Suppose a manufacturer sold a washing machine for a taxable of Rs.12,000 to the wholesaler. Wholesaler sold it to the retailer for Rs.15,000 (taxable value). Retailer sold it to the customer for Rs.20,000 (taxable value). Rate of GST is 28%. Find
GST Payable by Manufacturer, Wholesaler, Retailers

- Solution :** GST Payable by manufacturer
 $= 12000 \times \frac{28}{100} = \text{Rs. } 3360$

$$\begin{aligned} \text{Output tax of wholesaler} &= 15000 \times \frac{28}{100} \\ &= \text{Rs. } 4200 \end{aligned}$$

$$\begin{aligned} \text{GST Payable by wholesaler} \\ &= \text{Output tax} - \text{Input Tax} \\ &= \text{Rs. } 4200 - \text{Rs. } 3360 = \text{Rs. } 840 \end{aligned}$$

$$\text{Output tax by retailer} = 20000 \times \frac{28}{100} = 5600$$

$$\begin{aligned} \text{GST Payable by Retailer} \\ &= \text{Output of retailer} - \text{Input by retailer} \\ &= \text{Rs. } 5600 - \text{Rs. } 4200 = 1400 \end{aligned}$$

$$\text{Total GST} = 3360 + 840 + 1400 = 5600$$

EXERCISE 9.6

- 1) M/s Janaseva sweet mart sold sweets of Rs.3,86,000. What CGST and SGST he will pay if the rate of GST is 5%?
- 2) Janhavi Gas Agency purchased some gas cylinders for Rs. 500000 and sold them to the customers for Rs. 590000. Find amount of GST payable and amount of ITC 5% GST is applicable.
- 3) A company dealing in mobile phones purchased mobile phones worth Rs500000 and sold the same to customers at RS.6,00,000. Find amount Of ITC and amount of GST if rate of GST is 12%.
- 4) Prepare Business to customers (B2C) tax invoice using given information. Write the name of supplier, address, state, Date, Invoice Number, GSTIN etc. as per your choice

Supplier : M/s

Address :

State : Date :

Invoice No : GSTIN :

Particular : Rate of Sarrees – Rs.2750 Rate of
GST 5% HSN 5407–2 pcs

Rate of Kurta – Rs. 750 Rate of GST 12%
HSN 5408

- 5) Heena Enterprise sold cosmetics worth Rs. 25000 to Leena traders, a retailer. Leena Traders sold it further to Meena Beauty Products for Rs. 30000. Meena Beauty Product sold it further to the customers for Rs. 40000. Rate of GST is 18%

Find i) GST Payable by each party

ii) CGST and SGST

- 6) ‘Chitra furnishings’ purchased tapestry (curtain cloth) for Rs. 2800000 and sold for Rs.4480000 Rate of GST is 5%. Find,

i) Input Tax

ii) Output Tax

iii) ITC

iv) CGST and SGST

- 7) Two friends ‘Aditi’ and ‘Vaishali’ went to a restaurant. They ordered 2 Masala Dosa costing Rs. 90 each 2 coffee costing Rs.60 each and 1 sandwich costing Rs. 80. If GST is charged at 5% Find Total amount of bill including GST.

9.7 Shares and Dividends



Let's Recall

In 10th standard we have studied Shares, Dividend, Return on investment and Brokerage. Now we will revise these terms and practice some examples.

Stock Capital:

The total amount of money needed to run the company is called the stock capital.

Shares

The whole capital is divided into small units. Each unit or part is called a share. Company can

raise capital by issuing shares. An individual or an organization can buy shares and that individual or organization will be owner of the company to the extent proportional to the shares owned by him.

Definition - A unit of ownership that represents an equal proportion of a company’s capital. It entitles its holder (the shareholder) to an equal claim on the company’s profits and an equal obligation for the company’s debts and losses.

Two major types of shares are

- (1) ordinary shares (common stock), which entitle the shareholder to share in the earnings of the company as and when they occur, and to vote at the company’s annual general meetings and other official meetings, and
- (2) Preference shares (preferred stock) which entitle the shareholder to a fixed periodic income (interest) but generally do not give him or her voting rights.

Dividend:

The annual profit distributed among shareholders is called dividend.

Dividend is paid periodically as per share or as a percentage.

Face Value:

The value of a share or stock printed on the share-certificate is called its Face Value or Nominal Value or Par Value.

Market Value:

The value of a share or stock at which it is bought or sold readily in market place.

The stock of different companies are sold and bought in the open market through brokers at stock-exchanges. A share or stock is said to be:

At premium or above par, if its market value is more than its face value.

At par, if its market value is the same as its face value.

At discount or below par, if its market value is less than its face value.

Thus, if a Rs. 100 stock is quoted at premium of 16, then market value of the stock

$$= \text{Rs}100 + 16) = \text{Rs. } 116.$$

Likewise, if a Rs. 100 stock is quoted at a discount of 7, then market value of the stock

$$= \text{Rs. } (100 - 7) = 93.$$

Brokerage:

The broker's charge is called brokerage.

- (i) When stock is purchased, brokerage is added to the cost price.
- (ii) When stock is sold, brokerage is subtracted from the selling price.



Let's Remember

The face value of a share always remains the same.

The market value of a share changes from time to time. Dividend is always paid on the face value of a share.

SOLVED EXAMPLES

Ex.1. Madhav buys shares of face value Rs.50 of a company which pays 10 % dividend. At what price did he buy each share from the market if his profit is 16 % on his investment?

Solution: Let the market value (M.V.) of each share be x.

The dividend is calculated on nominal value.

The dividend on one share = 10% of Rs. 50 = Rs. 5.

Therefore, he earned Rs. 5 on an investment of X

$$\text{A profit of } 16 \% \text{ on } X = \frac{16}{100} \times X = \frac{4X}{25}$$

$$\text{Therefore, } \frac{4X}{25} = \text{Rs.}5$$

$$X = \text{Rs.}25 \times \frac{5}{4}$$

$$X = \text{Rs. } \frac{125}{4}$$

$$X = \text{Rs. } 31.25$$

Therefore, Madhav bought each share at Rs. 31.25 from the market.

Ex.2 : Reeta bought 6% Rs. 100 shares at Rs.120. Aditi bought 8% Rs. 20 shares at Rs.30. Whose investment was better?

Solution: 6% Rs.100 shares at Rs.120

i.e., the annual income from 1 share of nominal value Rs. 100 is Rs. 6, investment for 1 share being Rs.120.

$$\text{Therefore, profit percentage} = \frac{6}{120} \times 100 = 5$$

Therefore, Reeta's shares give her a profit of 5%

8 % Rs.20 shares at Rs. 30

i.e., the annual income from 1 share of nominal

$$\text{value Rs. 20 is } \text{Rs. } 8 \times \frac{20}{100} = \text{Rs. } \frac{8}{5} = \text{Rs.}1.6$$

Investment for 1 share being Rs. 30.

Profit percentage

$$= \text{Rs.}(1.6 \div \text{Rs.}30) \times 100 = 5.33\%$$

Therefore, Aditi's shares give her a profit of 5.33% Therefore, Aditi's investment was better.

Ex.3 : Mohan invested Rs.67200 in Rs.100 shares which are quoted at Rs.120. Calculate the income if 12% dividend is declared on the shares.

Solution:

Total sum invested = Rs.67200 and market value (M.V.) of each share = Rs.120.

Therefore, number of shares bought

$$= \text{Rs.}67200 / 120 = 560$$

According to the problem, dividend on 1 share = 12% of face value.

$$= 12\% \text{ of Rs.}100$$

$$= \text{Rs.}12$$

Therefore, the total income from the shares

$$= 560 \times 12 = \text{Rs.}6720$$

EXERCISE 9.7

Ex.4 : Mr. Pratik bought 50 shares, each of nominal value Rs.100. After one year he received Rs. 400 as dividend against them. Find the rate of dividend on his shares.

Solution:

$$\text{The dividend on one share} = \text{Rs. } \frac{400}{50} = \text{Rs } 8.$$

Therefore, the dividend was Rs. 8 on a share of face value Rs. 100.

Therefore, the rate of dividend

$$= \text{Rs. } \frac{8}{100} \times 100 \% = 8\%$$

Ex.5 : Calculate the dividend due at the end of a year on 250 shares of Rs. 50 each, if the half-yearly dividend is 4 % of the value share.

Solution:

Given, half-yearly dividend on 1 share

$$= 4\% \text{ of } 50$$

Therefore, the yearly dividend on 1 share

$$= 8\% \text{ of Rs. } 50$$

$$= \frac{8}{100} \times 50$$

$$= \text{Rs. } 4$$

Total dividend due at the end of the year

$$= 250 \times 4 = \text{Rs. } 1000$$

Ex. 6 : A company declares semi-annual dividend of 6 %. Chitra has 500 shares of face value Rs. 25 each. Find Chitra's annual income.

Solution:

Total nominal value of shares

$$= \text{Rs. } 25 \times 500 = \text{Rs. } 12500$$

Therefore, semi-annual dividend

$$= 6 \% \text{ of Rs. } 12500$$

$$= \frac{6}{100} \times 12500$$

$$= \text{Rs. } 750.$$

Therefore, his annual income

$$= \text{Rs. } 750 \times 2 = \text{Rs. } 1500.$$

- Shantanu has a choice to invest in Rs.10 shares of two firms at Rs.13 or at Rs.16. If the first firm pays 5% dividend and the second firm pays 6% dividend per annum, find:
 - Which firm is paying better?
 - If Shantanu invests equally in both the firms and the difference between the return from them is Rs. 30. Find how much, in all, does he invest.
- A dividend of 9% was declared on Rs.100 shares selling at a certain price in the stock market. If the rate of return is 7.5%, calculate
 - The market price of each share, and
 - The amount to be invested to obtain an annual dividend of Rs. 630.
- Nilesh has the option of investing his money in 8% Rs. 10 shares at a premium of Rs.3.50 or 7% Rs. 100 shares at a premium of 20%. Which of the two investments will be more profitable for him?
- Sudhakar invests Rs. 1344 in buying shares of face value Rs.24 selling at 12% premium. The dividend on the shares is 15% per annum. Calculate
 - The number of shares Aditya buys, and
 - The dividend he receives annually.
- Sameer invests Rs. 5625 in a company paying 7% per annum when share of Rs. 10 stands for Rs.12.50. Find Sameer's income from this investment.If he sells 60 % of these shares for Rs.10 each, find his gain or loss in this transaction.
- Geeta buys Rs.100 shares of a company which pays 15 % dividend. She buys the shares at a price from the market that gives her 10% return on her investment. At what price did she buy each share?

7. Tejas invests in 9% Rs. 100 shares at Rs. 145 but Shail invests in 7% Rs. 100 shares at Rs.116. whose investment is better?
8. A 6% share yields 8%. Find the market value of a Rs 100 share.
9. Ashwini bought Rs. 40 shares at a premium of 40%. Find the income, if Ashwini invests Rs. 14000 in these shares and receives a dividend at the rate of 8% on the nominal value of the shares.
10. Mr. Rutvik Invests Rs. 30,000 in buying shares of a company which pays a 12 % dividend annually on Rs. 100 shares selling at a premium of Rs. 50. Find
 - (i) The number of shares bought by Mr. Rutvik, and
 - (ii) His annual income from the shares.
11. Rasika bought Rs. 40 shares at a discount of 40%. Find the income, if she invests Rs.12000 in these shares and receives a dividend at the rate of 11% on the nominal value of the shares.
12. Nisha invests Rs. 15840 in buying shares of nominal value Rs.24 selling at a premium of 10%. The company pays a 15% dividend annually. Find
 - (i) The dividend she receives annually, and
 - (ii) The rate of return from her investment.
13. Ashutosh buys 400, Rs. 100 shares at a discount of 20 % and receives a return of 12% on his money. Calculate:
 - (i) The amount invested by Ashutosh.
 - (ii) The rate of dividend paid by the company.
14. Vaishnavi bought 1000, Rs.100 shares from the stock market carrying 8% dividend quoted at Rs.130. A few days later the market value of the shares went up by 10%. Vaishnavi sold all her shares. What was her total income from this transaction?
15. Mr. Dinesh invests Rs. 20800 in 6% Rs. 100 shares at Rs. 104, and Rs. 14300 in 10.5% Rs. 100 shares at Rs.143. What will be his annual income from the shares?
16. A company declares a semi-annual dividend of 5%. Daniel has 400 shares of company. If Daniel's annual income from the shares is Rs. 1000, find the face value of each share.
17. Bhargav buys 400, twenty-dollar shares at a premium of Rs. 4 each and receives a dividend of 12%. Find:
 - (i) The amount invested by Bhargav
 - (ii) His total income from the shares.
 - (iii) Percentage return on his money.
18. Anil buys 350 Rs 100 shares of a company at a premium of 20% from the market. The company pays 12% dividend annually. Find
 - (i) the investment made by the Anil,
 - (ii) his annual income from the shares, and
 - (iii) the rate of return from the shares.



Let's Remember

- Percentage increase

$$= \frac{\text{Increase in Quantity}}{\text{Original Quantity}} \times 100$$
- Percentage decrease

$$= \frac{\text{Decrease in Quantity}}{\text{Original Quantity}} \times 100$$
- To increase a number by x % multiply it by $\frac{100+x}{100}$
- To decrease a number by x % multiply it by $\frac{100-x}{100}$

- If A's income is r % more than B's income then B's income is less than A's income by

$$\frac{r}{100+r} \times 100 \%$$

- If A's income is r % less than B's income then B's income is more than A's income by

$$\frac{r}{100-r} \times 100 \%$$

- If price of a commodity increases by x % then to keep the expenses same the consumption

$$\text{must be reduced by } \frac{x}{100+x} \times 100 \%$$

- If price of a commodity decreases by x % and expenses are same, the consumption

$$\text{can be increased by } \frac{x}{100-x} \times 100 \%$$

- Gain = (S.P.) – (C.P.)

- Loss = (C.P.) – (S.P.)

- Gain Percentage : (Gain %)

$$\text{Gain \%} = \frac{\text{Gain} \times 100}{\text{C.P.}}$$

- Loss Percentage : (Loss %)

$$\text{Loss \%} = \frac{\text{Loss} \times 100}{\text{C.P.}}$$

- Selling Price (S.P.) when there is Gain.

$$\frac{100 + \text{gain}\%}{100} \times \text{C. P.}$$

- Selling Price (S.P.) when there is Loss.

$$\frac{100 - \text{Loss}\%}{100} \times \text{C. P.}$$

- Cost Price (C.P.) when there is Gain.

$$\text{C.P.} = \frac{100}{100 + \text{gain}\%} \times \text{S. P.}$$

- Cost Price (C.P.) when there is Loss.

$$\text{C.P.} = \frac{100}{100 - \text{loss}\%} \times \text{S. P.}$$

- When a person sells two similar items, one at a gain of x %, and the other at a loss of x %, then the seller always incurs a loss given by :

$$\text{Loss}\% = \left(\frac{\text{common loss and gain}\%}{10} \right)^2 = \left(\frac{x}{10} \right)^2$$

- Sometimes a seller claims to sell goods at cost price. But he uses a false weight. Then he earns profit.

$$\text{To find profit percent} = \pm \frac{\text{Error}}{\text{True value} - \text{Error}} \times 100$$

- Simple interest : $I = \frac{Pn.r.}{100}$ and

$$A = P + \frac{Pn.r.}{100}$$

- Compound interest : $A = P \left(1 + \frac{r}{100} \right)^n$

- **Dividend :-** The annual profit distributed among shareholders is called dividend. Dividend is paid annually as per share or as a percentage.

- **Face Value :-** The value of a share or stock printed on the share - certificate is called its Face Value or Nominal Value or Par Value.

- **Market Value :-** The value of a share or stock at which it is bought or sold readily in market place.

- **Brokerage :-** The broker's charge is called brokerage.

MISCELLANEOUS EXERCISE - 9

- 1) A man buys a house for Rs 10 lakh and rent it. He puts 10% of the annual rent aside for repairs, Pays Rs. 1000 as annual taxes and realizes 8% on his investment thereafter . Find the annual rent of the house.

- 2) Rose got 30% of the maximum marks in an examination and failed by 10 marks. However, Lily who appeared for the same examination got 40% of the total marks and got 15 marks more than the passing marks. What were the passing marks in the examination ?
- 3) Ankita's Salary was reduced by 50%. Again the reduced salary was increased by 50%. Find loss in terms of percentage.
- 4) By selling 300 lunch boxes, a shopkeeper gains the selling price of 100 lunch boxes. Find his gain percentage.
- 5) A salesman sold an article at a loss of 10%. If the selling price has been increased by Rs. 80, there would have been a gain of 10%. What was cost of the article ?
- 6) Find the single discount equivalent to a series discount of 10%, 20% and 15%.
- 7) Reshma put an amount at simple interest at a certain rate for 3 years. Had she been put at 2% higher rate, she would have received Rs 360 more. Find the sum.
- 8) The compound interest on Rs. 30000 at 7% p.a. is Rs. 4347. What is the period in years.
- 9) The value of the machine depreciates at the rate of 15% p.a. It was purchased 2 years ago. Its present value is Rs. 7225. What was the purchase price of the machine ?
- 10) A tree increases annually by $\frac{1}{8}$ of its height. By how much will it increase after $2\frac{1}{2}$ years. If its length today is 8 m. ?
- 11) A building worth Rs. 121000 is constructed on land worth Rs. 81000. After how many years will the value of both be the same if land appreciates at 10% pa. and buildings depreciates at 10% p.a.
- 12) Varun invested 25%, 30% and 20% of his savings in buying share of three different companies. 'A', 'B' and 'C' which declared dividends. 10%, 12% and 15% respectively. If his total income on account of dividends is Rs. 6370/-, find the amount he invested in buying shares of company 'B'.
- 13) Find the annual dividend received from Rs. 25000, 8% stock at 108.
- 14) A, B and C enter into partnership . A invests 3 times as much as B invests and B invests two third of what 'C' invests. At the end of the year, the profit earned is Rs. 8800. What is share of 'B' ?
- 15) The ratio of investment of two partners Santa and Banta is 11 : 12 and the ratio of their profits is 2 : 3. If Santa invested the money for 8 months, then for how much time Banta his money ?
- 16) Akash, Sameer and Sid took a house on rent for once year for Rs.16236. They stayed together for 4 months and then sid left the house. After 5 more months. Sameer also left the house. How much rent should each pay ?
- 17) Ashwin Auto Automobiles sold 10 motorcycles. Total sales amount was Rs. 680000. 18% GST is applicable. Calculate how much CGST and SGST the firm has to pay.
- 18) 'Sweet 16' A ready made garments shop for Womens garments, purchased stock for Rs. 400000 and sold that stock for 550000 (12% GST is applicable) Find,
 - i) Input Tax Credit
 - ii) CGST and SGST paid by the firm.

Activity 9.1

Find face value and market value of following companies.

Sr. No.	Stocks	Face Value	Market Value
1	ONGC		
2	TCS		
3	SBI		
4	HDFC Bank		
5	Reliance		

Activity 9.2

Let price of P.A.B. motors Stock is Rs. 180

Find Brokerage @ 0.50% =

GST @ 0.01% =

Other charges @ 0.09 % =

Total cost to buy one share of P.A.B. motors =



ANSWERS

CHAPTER 1

Exercise 1.1

- 1) $Q_1 = 10.9, Q_2 = 12, Q_3 = 14$
- 2) $Q_1 = 150.25, Q_3 = 165$
- 3) $Q_1 = 191$
- 4) $Q_3 = 650$
- 5) $Q_1 = 2, Q_2 = 3, Q_3 = 4$
- 6) $Q_2 = 165$
- 7) 12, 13
- 8) $Q_1 = 10500, Q_2 = 11500, Q_3 = 12500$
 $Q_1 < Q_2 < Q_3$
- 9) $(Q_1, Q_3) = (225, 585)$
- 10) 81

Exercise 1.2

- 1) $D_6 = 69.2, P_{85} = 80.05$
- 2) $D_8 = 379, P_{90} = 420$
- 3) $D_2 = 120, P_{65} = 280$
- 4) $P_{15} = 11000, P_{65} = 15000, P_{92} = 16000$
- 5) a) 30% b) 42%
- 6) $D_4 = 13, P_{48} = 14.6$
- 7) $D_9 = 98, P_{20} = 66.85$
- 8) 18, 20
- 9) $(P_{20}, P_{80}) = (1625, 4400)$
- 10) 24.72%

Exercise 1.3

- 1) $Q_1 = 26, D_6 = 32.5, P_{85} = 40$
- 2) $Q_1 = 150, Q_2 = 228, Q_3 = 298$
- 3) $Q_2 = 574$

- 4) (i) $(D_3, D_7) = (20, 36, 5)$, (ii) 67
- 5) $Q_2 = 19, D_2 = 13, P_{65} = 21.2$
- 6) $D_1 = 22, Q_1 = 30.5, P_{40} = 37$
- 7) $D_3 = 44, D_5 = 55.5, D_8 = 68$
- 8) $Q_2 = 17.5$
- 9) $(Q_1, Q_3) = (1025, 1248)$
- 10) $D_3 = 79.5, P_{65} = 93.5$

MISCELLANEOUS EXERCISE - 1

- 1) $P_{17} = 2, Q_2 = 3, D_7 = 4$
- 2) $Q_2 = 5, D_1 = 2, P_{95} = 8$
- 3) Mathematics $(Q_2) = 33.5$,
Statistics $(Q_2) = 30.5$,
Knowledge of Mathematics is higher than
Statistics.
- 4) 25
- 5) $Q_1 = 128.125, D_6 = 213.33, P_{15} = 53.57$
- 6) 18, 20
- 7) 575
- 8) $D_3 = 25, Q_2 = 29, P_{35} = 26$
- 9) 256
- 10) $Q_2 = 165$.
- 11) $Q_2 = 41$
- 12) $Q_2 = 55$
- 13) 14, 12
- 14) $Q_2 = 11.25$
- 15) $Q_2 = 36$
- 16) $Q_1 = 220, Q_3 = 340$, (i) 55 (ii) 60
- 17) $Q_2 = 48$
- 18) $Q_1 = 9.725, D_6 = 10.725, P_{78} = 11.375$
- 19) $Q_1 = 52.1875, Q_2 = 57.75, Q_3 = 63.5625, 31$
- 20) $Q_1 = 58.67$

CHAPTER 2

Exercise 2.1

- 1) 717
- 2) 11
- 3) 10
- 4) 5.5
- 5) 17.5
- 6) 2
- 7) 5.625
- 8) 1.965

Exercise 2.2

- 1) $8, 2\sqrt{2}$,
- 2) 380, $2\sqrt{95}$,
- 3) 6.1911, $\sqrt{6.1911}$,
- 4) 4.8, $\sqrt{4.8}$,
- 5) 1.2, $\sqrt{1.2}$,
- 6) 2, 4
- 7) $\sqrt{3.3514}$
- 8) 15.5 – 25.5, 25.5 – 35.5,, 95.5 – 105.5

Exercise 2.3

- 1) 44, $\sqrt{55.6516}$
- 2) $\sqrt{10.5}$
- 3) 31.62%
- 4) 20%
- 5) 3.76
- 6) $CV(P) = 27.27\%$, $CV(Q) = 33.33\%$
- i) Worker P is more consistent.

- ii) Worker Q seems to be faster in completing the job.
- 7) $CV_1 = 1.07\%$, $CV_2 = 2.5\%$
- i) First department has a larger bill.
- ii) Second department has larger variability in wages.
- 8) 22.36%
- 9) $CV(A) = 42.49\%$, $CV(B) = 33.50\%$
Team B is more consistent.
- 10) $CV(M) = 10\%$, $CV(S) = 12\%$
Statistics shows more variability

MISCELLANEOUS EXERCISE - 2

- 1) 89
- 2) 30
- 3) 60
- 4) 16.75
- 5) 12.59
- 6) 4.84
- 7) 3.75
- 8) 6.6, 2.57
- 9) 2.16, $\sqrt{2.16}$
- 10) 78, 17.20, 22.05%
- 11) 50, 44.84
- 12) 40.4, $\sqrt{81.13}$
- 13) 75, 10.07
- 14) $\sqrt{7.5}$
- 15) $CV_1 = 22.22\%$, $CV_2 = 20.83\%$, Brand II is more variable
- 16) 39.49%

CHAPTER 3

Exercise 3.1

- 1) - 0.45
- 2) 63, 61
- 3) 1
- 4) 29
- 5) -0.1881, Negatively skewed
- 6) 0
- 7) -0.5
- 8) -0.143

MISCELLANEOUS EXERCISE - 3

- 1) 1
- 2) -1.5
- 3) 0.2
- 4) -0.2
- 5) 70, 30
- 6) 195.2, 198.4
- 7) 0.4760
- 8) 0.3194
- 9) 1.3182
- 10) 0.6

CHAPTER 4

Exercise 4.1

1. Bivariate frequency distribution :

X	200-300	300-400	400-500	Total
Y				
200-300	6	6	1	13
300-400	-	4	5	10
400-500	-	-	2	2
Total	6	10	9	25

- i) Marginal frequency distributions of income (X) :

X	200-300	300-400	400-500	Total
Frequency	6	10	9	25

Marginal frequency distributions of expenditure (Y) :

Y	200-300	300-400	400-500	Total
Frequency	13	10	2	25

- ii) Conditional frequency distributions of X when Y is between 300-400

X	200-300	300-400	400-500	Total
Frequency	-	4	6	10

- iii) Conditional frequency distributions of Y when X is between 200-300

Y	200-300	300-400	400-500	Total
Frequency	6	-	-	6

- iv) Number of families having their income \geq Rs.300 and expenses \leq Rs.400

$$= 6 + 1 + 4 + 6 = 17$$

2. Bivariate frequency distribution :

X \ Y	2	3	4	5	6	f _y
1	-	1	2	-	1	4
2	-	1	-	2	-	3
3	2	1	3	-	-	6
4	-	2	-	-	1	3
5	5	-	3	1	-	9
f _x	7	5	8	3	2	25

Marginal frequency distributions of income (X) :

X	2	3	4	5	6	Total
Frequency	7	5	8	3	2	25

Marginal frequency distributions of expenditure (Y) :

Y	1	2	3	4	5	Total
Frequency	4	3	6	3	9	25

3. Bivariate frequency distribution :

X \ Y	25	26	27	28	29	Total
19	(2)	(1)	-	-	-	3
20	(2)	(1)	-	(2)	-	5
21	-	(2)	(1)	-	-	3
22	-	-	(3)	(1)	-	4
23	(2)	-	(1)	-	(2)	5
Total	6	4	5	3	2	20

i) Marginal distributions of X :

X	25	26	27	28	29	Total
F	6	4	5	3	2	20

ii) Marginal distributions of Y :

Y	19	20	21	22	23	Total
F	3	5	3	4	5	20

iii) Conditional frequency distributions of age of husbands (X) when the age of wife (Y) is 23 years. :

X	25	26	27	28	29	Total
F	2	-	1	-	2	5

4. Let X denotes the marks in stats and Y denotes the marks in English Bivariate frequency distribution :

X \ Y	20-30	30-40	40-50	Total
20-30	(1)	(2)	(1)	4
30-40	(3)	(2)	(11)	7
40-50	(2)	(1)	(1)	4
Total	6	5	4	15

i) Marginal frequency distributions of (X) :

X	20-30	30-40	40-50	Total
F	6	5	4	15

Marginal frequency distributions of (Y) :

Y	20-30	30-40	40-50	Total
F	4	7	4	15

ii) Conditional frequency distributions of Y and X = 47

X	20-30	30-40	40-50	Total
F	2	2	1	15

5. Bivariate frequency distribution :

X \ Y	35-39	40-44	45-49	50-54	Total
150-154	(3)	(2)	(1)	(1)	7
155-159	(1)	(3)	(2)	(1)	7
160-165	-	-	(1)	(3)	4
165-169	-	-	-	(2)	2
Total	4	5	4	7	20

i)(a) Marginal frequency distribution of X :

X	35-39	40-44	45-49	50-54	Total
F	4	5	4	7	20

(b) Marginal frequency distribution of Y :

Y	150-154	155-159	160-164	165-169	Total
F	6	8	4	2	20

ii) Conditional frequency distribution of Y, when $155 \leq X \leq 159$

Y	150-154	155-159	160-164	165-169	Total
F	1	3	3	1	8

Ex. 4.2 :

- 1) 0 2) 3.37 3) 1.07 4) 2.66 5) 30.625

MISCELLANEOUS EXERCISE - 4

1.

X/Y	0-4	5-9	10-14	15-19	Total
5-8	(2)	-	(3)	(1)	6
9-12	(2)	(9)	(1)	-	12
13-16	(1)	(6)	(4)	(1)	12
Total	5	15	8	2	30

i)(a) Marginal frequency distribution of X :

X	0-4	5-9	10-14	15-19	Total
F	5	15	8	2	30

(b) Marginal frequency distribution of X :

X	5-8	9-12	13-16	Total
F	6	12	12	30

ii) Conditional frequency distribution of X, when $X < 10$

Y	5-8	9-12	13-16	Total
F	2	11	7	20

2. Let us denote the age by X and marks by Y

Y/X	16-18	18-20	20-22	22-24	Total
10-20	(2)	-	-	-	2
20-30	-	-	-	-	-
30-40	-	-	(1)	(5)	6
40-50	(3)	(2)	(3)	(1)	9
50-60	(2)	(2)	(4)	(1)	9
60-70	-	(1)	(1)	(2)	4
Total	7	5	9	9	30

i)(a) Marginal frequency distribution of X :

X	16-18	18-20	20-22	22-24	Total
F	7	5	9	9	30

(b) Marginal frequency distribution of Y :

Y	10-20	20-30	30-40	40-50	50-60	60-70	Total
F	2	-	6	9	9	4	30

ii) Conditional frequency distribution of marks (Y), when age is in 20-22

Y	10-20	20-30	30-40	40-50	50-60	60-70	Total
F	-	-	1	3	4	1	9

3.i)

X/Y	115-125	125-135	135-145	145-155	155-165	165-175	Total
60-62	2	1	-	-	-	-	3
62-64	1	-	3	-	-	-	4
64-66	1	1	2	1	-	-	5
66-68	-	2	-	2	-	-	4
68-70	-	1	1	-	1	1	4
Total	4	5	6	3	1	1	20

i)(a) Marginal frequency distribution of X :

X	115-125	125-135	135-145	145-155	155-165	165-175	Total
F	4	5	6	3	1	1	20

(b) Marginal frequency distribution of Y :

Y	60-62	62-64	64-66	66-68	68-70	Total
F	3	4	5	4	4	20

iii) Conditional frequency distribution of sales when expenditure is between 64-66

X	115-125	125-135	135-145	145-155	155-165	165-175	Total
F	1	1	2	1	-	-	5

iv) Conditional frequency distribution of expenditure when sales are between 125-135

Y	60-62	62-64	64-66	66-68	68-70	Total
F	1	-	1	2	1	5

4.

Y/X	35-45	45-55	55-65	65-75	Total
115-130	(4)	-	-	-	4
130-145	(2)	(1)	(3)	-	6
145-160	(1)	(1)	(2)	(3)	7
160-175	(1)	(2)	(2)	(2)	7
Total	8	4	7	5	24

i)(a) Marginal frequency distribution of X :

X	35-45	45-55	55-65	65-75	Total
F	8	4	7	5	24

(b) Marginal frequency distribution of Y :

Y	115-130	130-145	145-160	160-175	Total
F	4	6	7	7	24

(ii) Conditional frequency distribution of Y, when $X \leq 45$

Y	115-130	130-145	145-160	160-175	Total
F	4	2	1	1	8

5.

Y/X	80-90	90-100	100-110	110-120	120-130	Total
500-600	-	(1)	-	(2)	(1)	4
600-700	(2)	(2)	(2)	(1)	-	7
700-800	(1)	(4)	-	-	(1)	6
800-900	(1)	(3)	(1)	-	(3)	8
900-1000	(3)	(1)	-	(1)	-	5
Total	7	11	3	4	5	30

i) Marginal frequency distribution of X :

X	80-90	90-100	100-110	110-120	120-130	Total
F	7	11	3	4	5	30

ii) Marginal frequency distribution of Y :

Y	500-600	600-700	700-800	800-900	900-1000	Total
F	4	7	6	8	5	30

6) 2.38 7) 0.67 8) 10.614 9) 4.31 10) 0.4076

CHAPTER 5

Exercise 5.1

- 1) Positive correlation
- 2) Positive Correlation
- 3) NO Correlation
- 4) 0.89
- 5) 18.75
- 6) i) 5 ii) -0.92
- 7) 0.1732
- 8) 13.33.

MISCELLANEOUS EXERCISE 5

- 1) 0.5
- 2) 10
- 3) 9

- 4) 10
- 5) 0.94, High degree of positive correlation
- 6) -1. Perfect negative correlation
- 7) 1, Perfect positive correlation
- 8) No change
- 9) Same value

CHAPTER 6

Exercise 6.1

- 1) 50
- 2) 30, 20
- 3) 12
- 4) (i) 25, (ii) 20
- 5) (i) 100 (ii) 48
- 6) 125
- 7) 124
- 8) 31
- 9) 90
- 10) 225
- 11) 24
- 12) 276
- 13) 207
- 14) 12
- 15) 216

Exercise 6.2

- 1) (i) 40320 (ii) 720 (iii) 39600 (iv) 2
- 2) (i) 665280 (ii) 2 (iii) 720 (iv) 12
- 3) (i) 84 (ii) 29 (iii) 5793 (iv) 20160
- 4) (i) $\frac{10!}{4!}$ (ii) $3^5 \times 5!$ (iii) $\frac{9!}{5!}$ (iv) $5^5 \times 5!$
- 5) (i) 28 (ii) 1
- 6) (i) 1848 (ii) $\frac{43}{14}$ (iii) 5

7) (i) 6 (ii) 8

8) (i) 7 (ii) 8

9) (i) 11 (ii) 11

10) 5

13) (i) 3370 (ii) $\frac{8}{25}$

14) $\frac{(2n)!}{n!} = 2^n (2n-1)(2n-3)\dots 5.3.1$

Exercise 6.3

1) 9

2) $m = 6, n = 2$

3) 6

5) (i) 2401 (ii) 840

6) (i) 30240 (ii) 25200 (iii) 1800 (iv) 5040

7) $\frac{12!.13!}{7}$

8) (i) 1440 (ii) 720

9) 144

10) (i) 1296 (ii) 360

11) 100

12) 720 (i) 120 (ii) 600

13) (i) 46,800 (ii) 20,800

14) 243

15) (i) 2880 (ii) 5040

Exercise 6.4

1) (i) 120 (ii) 60480 (iii) 90720 (iv) 5040

2) 1260

3) (i) 70 (ii) 37

4) $\frac{13!}{5!.4!.4!}$

5) $\frac{12!}{2!.3!.2!}, \frac{8 \times 5!}{2! \times 3! \times 2!}$

6) $\frac{11!}{4!.2!.2!}$ (i) $\frac{9!.^{10}P_2}{4 \times 2 \times 2!}$ (ii) $\frac{8!}{2! \times 2!}$

7) 210

8) 60

9) $\frac{10!}{2!.3!.2!}$

10) 1260, 660

11) 180

12) 144

13) 360, 180

14) 180, 60

15) (i) 1800 (ii) 72

Exercise 6.5

1) 5040

2) $20!, 18! \times 2!$

3) (i) $22! \times 2!$, (ii) $2! \times 22!$

4) $\frac{14!}{2!}$

5) $18! \times 2!$

6) (i) $5! \times 2!$, (ii) $5! \times {}^5P_2$

7) $7! \times {}^8P_6$

8) $4! \times {}^3P_2$

9) $\frac{9!}{4!}$

10) $12 \times 13!$

Exercise 6.6

1) (i) 1365 (ii) 3160

(iii) ${}^{16}C_5 = 4368$ (iv) ${}^{19}C_{15} = 3876$

2) (i) 2 (ii) 7 (iii) 9

3) 4

4) (i) $n = 10, r = 3$, (ii) $n = 10, r = 4$

5) 8

6) 126

7) 7000

- 8) 120
- 9) 12
- 10) 190
- 11) ${}^n C_2 - n$; (a) 35 (b) 90 (c) 54
- 12) 190
- 13) (i) 45, (ii) 40
- 14) (i) 220, (ii) 216
- 15) 151200

Exercise 6.7

- 1) 20
- 2) 4
- 3) 1, 5 or 2
- 4) $n-1$
- 5) 6
- 6) $\frac{1}{r!}$
- 7) 11 or 7
- 8) ${}^{21} C_5$
- 9) (i) 2508, (ii) 1646, (iii) 4125
- 10) 16
- 11) 2275
- 12) 36873, 6885
- 13) 425
- 14) 51051
- 15) (a) 84, (b) 126

MISCELLANEOUS EXERCISE - 6

- 1) 41
- 2) 120
- 3) 720 AENREM
- 4) $n^n, n!$
- 5) 420
- 6) 990
- 7) 360

- 8) ${}^{26} C_6 + {}^{26} C_{10}$
- 9) 15
- 10) ${}^{30} C_7 \times {}^{23} C_{10} \times {}^{13} C_{13}$
- 11) 127
- 12) 336
- 13) 150
- 14) 1023
- 15) 48
- 16) ${}^8 P_4 = 1680$
- 17) $2^6 - 1 = 63$
- 18) ${}^{20} C_8 \times {}^{12} C_7 \times {}^5 C_5$
- 19) 924
- 20) 60

CHAPTER 7

Exercise 7.1

- 1) a) $S = \{HH, TH, HT1, HT2, HT3, HT4, HT5, HT6, TT1, TT2, TT3, TT4, TT5, TT6\}$ $n(S) = 14$
 b) $S = \{HH1, HH2, HH3, HH4, HH5, HH6, TH1, TH3, TH4, TH5, TH6, HTH, HTT, TTH, TTT\}$ $n(S) = 16$
- 2) $S = \{BB, BR, BG, RB, RR, RG, GB, GR, GG\}$ $n(S) = 9$
- 3) $S = \{H1, H2, H3, H4, H5, H6, T1, T2, T3, T4, T5, T6\}$
 a) $A = \{H2, H4, H6\}$
 b) $B = \{H2, H3, H5, T2, T3, T5\}$
 c) $C = \{T1, T4\}$
- 4) a) 2300, b) 21, c) 120, d) 720
- 5) a) $P = \{(1,2), (1,3), (1,5), (2,1), (2,2), (2,4), (2,6), (3,1), (3,3), (3,5), (3,6), (4,2), (4,4), (4,5), (5,1), (5,3), (5,4), (6,2), (6,3), (6,6)\}$

- b) $Q = \{(1, 6), (2, 5), (3, 4), (4, 3), (5, 2), (6, 1)\}$
- c) $R = \{(1, 1), (1, 2), (1, 4), (1, 6), (2, 1), (2, 3), (2, 5), (3, 2), (3, 4), (4, 1), (4, 3), (5, 2), (5, 6), (6, 1), (6, 5)\}$
- i) P and Q are mutually exclusive but not exhaustive.
- ii) Q and R are not mutually exclusive not exhaustive.
- 6) a) 52 b) 52
- 7) $S = \{(H_1 R_{11}), (H_1 R_{12}), (H_1 R_{13}), (H_1 B_{11}), (H_1 B_{12}), (T_1 R_{21}), (T_1 R_{22}), (T_1 B_{21}), (T_1 B_{22}), (T_1 B_{23}), (T_1 B_{24})\}$
- 8) a) $S = \{(5, 5), (5, 6), (5, 7), (5, 8), (6, 5), (6, 6), (6, 7), (6, 8), (7, 5), (7, 6), (7, 7), (7, 8), (8, 5), (8, 6), (8, 7), (8, 8)\}$
- b) $S = (5, 6), (5, 7), (5, 8), (6, 5), (6, 7), (6, 8), (7, 5), (7, 6), (7, 8), (8, 5), (8, 6), (8, 7)$

- c) $1 - \frac{{}^{39}C_4}{{}^{52}C_4}$ d) $\frac{{}^{12}C_3 \times {}^1C_1}{{}^{52}C_4}$
- 4) a) $\frac{7}{15}$ b) 5, 7, 3
- 5) a) $\frac{12}{75}$ b) $\frac{8}{75}$
- c) $\frac{7}{25}$ d) $\frac{1}{15}$
- 6) a) $\frac{{}^8C_3 \times {}^5C_2}{{}^{13}C_5}$
- b) $\frac{{}^8C_3 \times {}^5C_2 + {}^8C_4 \times {}^5C_1 + {}^8C_5 \times {}^5C_0}{{}^{13}C_5}$
- 7) $\frac{5}{6}$
- 8) a) $\frac{7! \times 3!}{9!}$ b) $\frac{6! \times {}^7P_3}{9!}$
- c) $\frac{7! \times 4}{9!}$ d) $\frac{7!}{9!}$ e) $\frac{3 \times 6 \times 7!}{9!}$
- 9) $\frac{4!3!}{6!} = \frac{1}{5}$

Exercise 7.2

- 1) a) $\frac{1}{9}$ b) $\frac{1}{12}$ c) $\frac{1}{6}$
- d) $\frac{11}{12}$ e) $\frac{1}{6}$ f) $\frac{1}{6}$
- 2) a) $\frac{{}^{26}C_2}{{}^{52}C_2}$ b) $\frac{{}^{13}C_2}{{}^{52}C_2}$ c) $\frac{{}^4C_2}{{}^{52}C_2}$
- d) $\frac{{}^{12}C_2}{{}^{52}C_2}$ e) $\frac{{}^{13}C_1 {}^{39}C_1}{{}^{52}C_2}$ f) $\frac{4 \times {}^{13}C_2}{{}^{52}C_2}$
- g) $\frac{13[{}^4C_2]}{{}^{52}C_2}$
- 3) a) $\frac{{}^4C_3 \times {}^4C_1}{{}^{52}C_4}$ b) $\frac{{}^{13}C_1 \times {}^{13}C_1 \times {}^{13}C_1 \times {}^{13}C_1}{{}^{52}C_4}$

Exercise 7.3

- 1) $\frac{23}{36}$
- 2) a) 1, b) $\frac{8}{13}$
- 3) a) $\frac{25}{51}$ b) $\frac{55}{221}$
- 4) a) $\frac{8}{25}$ b) $\frac{3}{5}$
- 5) a) $\frac{4}{5}$ b) $\frac{1}{2}$ c) $\frac{1}{5}$
- 6) a) $\frac{3}{20}$ b) $\frac{1}{10}$ c) $\frac{1}{4}$
- d) $\frac{17}{20}$ e) $\frac{1}{2}$

7) $\frac{97}{120}$

8) $\frac{4}{13}$

9) $\frac{16}{35}$

Exercise 7.4

1) $\frac{2}{11}$

2) $\frac{1}{6}$

3) $\frac{36}{61}$

4) independent

5) a) $\frac{3}{5}$ b) $\frac{2}{5}$ c) $\frac{3}{20}$

6) 0.8051

7) a) $\frac{1}{2}$ b) 0.4 c) 0.3

8) 0.96

9) a) $\frac{1}{4}$ b) $\frac{1}{2}$

10) $\frac{10}{21}$

11) $\frac{13}{35}$

12) $\frac{47}{90}$

13) $\frac{9}{169}$

MISCELLANEOUS EXERCISE - 7

1) $S = \{(m_1, m_2), (m_1, w_1), (m_1, w_2), (m_1, w_3), (m_2, w_1), (m_2, w_2), (m_2, w_3), (w_1, w_2), (w_1, w_3), (w_2, w_3)\}$

$E = \{(m_1, w_1), (m_1, w_2), (m_1, w_3), (m_2, w_1), (m_2, w_2), (m_2, w_3)\}$

2) $\frac{13}{32}$

3) $\frac{5}{6}$

4) $\frac{9}{10}$

5) $\frac{37}{50}$

6) $\frac{4}{13}$

7) $A_1, A_2,$ and A_3 are pair wise independent. They are not mutually independent.

8) $\frac{52}{77}$

9) a) $\frac{15}{91}$ b) $\frac{59}{91}$

10) $\frac{25}{648}$

11) 0.27

12) $\frac{20}{81}$

13) $\frac{7}{429}$

14) a) $\frac{73}{105}$ b) $\frac{32}{105}$

CHAPTER 8

Exercise 8.1

1) i) $-4 \leq x \leq \frac{7}{3}$, bounded

ii) $0 < x \leq 0.9$, bounded

iii) $-\infty < x < \infty$, unbounded

iv) $5 \leq x < \infty$, unbounded

v) $-11 < x < -2$, unbounded

vi) $-\infty < x < 3$, unbounded

2) i) $x > 12$, $x \in (12, \infty)$

ii) $x \leq 3$, $x \in (-\infty, 3]$

iii) $5 < x < 17$, $x \in (5, 17)$

iv) $-\frac{6}{7} < x < 2$, $x \in (-\frac{6}{7}, 2)$

3) Graph

1) i)

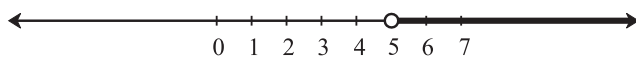

ii)

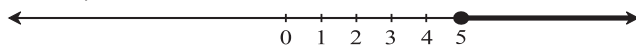

iii)

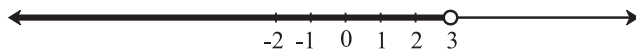

iv)

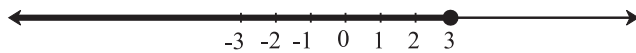

v)

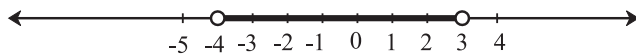

vi)

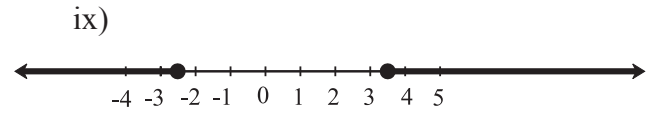
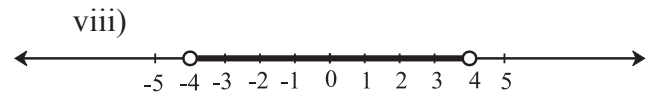
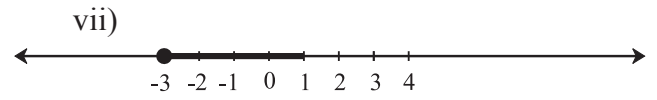
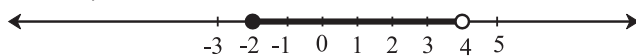

4) (i) $x > -\frac{3}{7}$, $x \in (-\frac{3}{7}, \infty)$

(ii) $x \leq \frac{5}{3}$, $x \in (-\infty, \frac{5}{3}]$

(iii) $x < 5$, $x \in (-\infty, 5)$

(iv) $x \geq 4$, $x \in [4, \infty)$

(v) $-\frac{8}{3} \leq x < \frac{13}{3}$, $x \in [-\frac{8}{3}, \frac{13}{3})$

(vi) $10 \leq x < 20$, $x \in [10, 20)$

(vii) $x \leq \frac{-1}{10}$ or $x \geq \frac{17}{10}$,
 $x \in (-\infty, -\frac{1}{10}) \cup [\frac{17}{10}, \infty)$

(viii) $-16 \leq x \leq 9$, $x \in [-16, 9]$

(ix) $x < -\frac{7}{2}$ or $x > -\frac{5}{2}$,

$x \in (-\infty, -\frac{7}{2}) \cup (-\frac{5}{2}, \infty)$

(x) $-5 < x < 3$, $x \in (-5, 3)$

5) 35

6) 82

7) (5, 7)

8) (6, 8), (8, 10), (10, 12)

9) 41

Exercise 8.2

1)

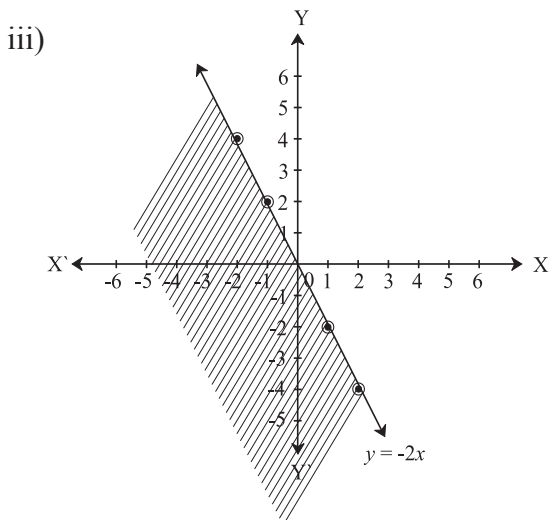
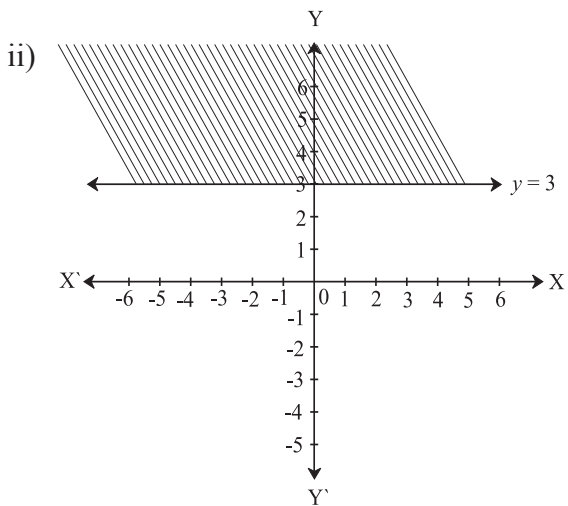
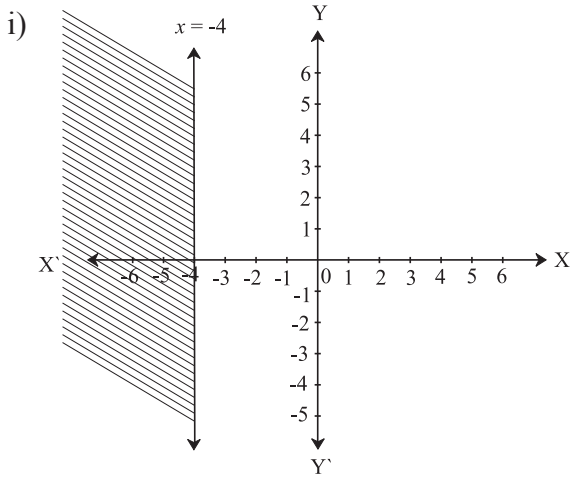

iv)

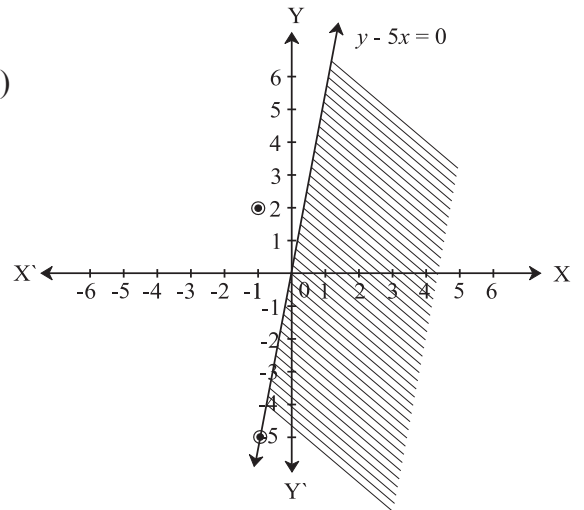

v)

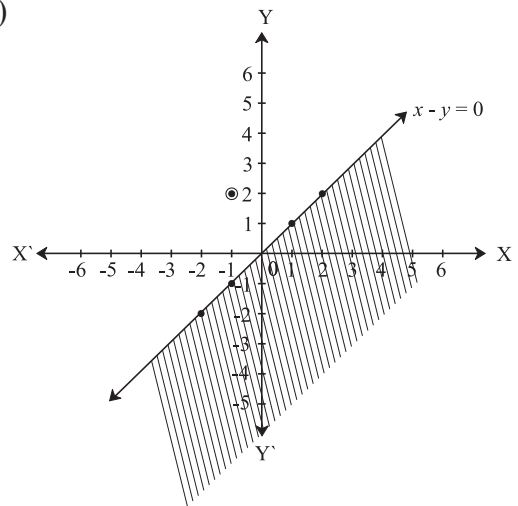

vi)

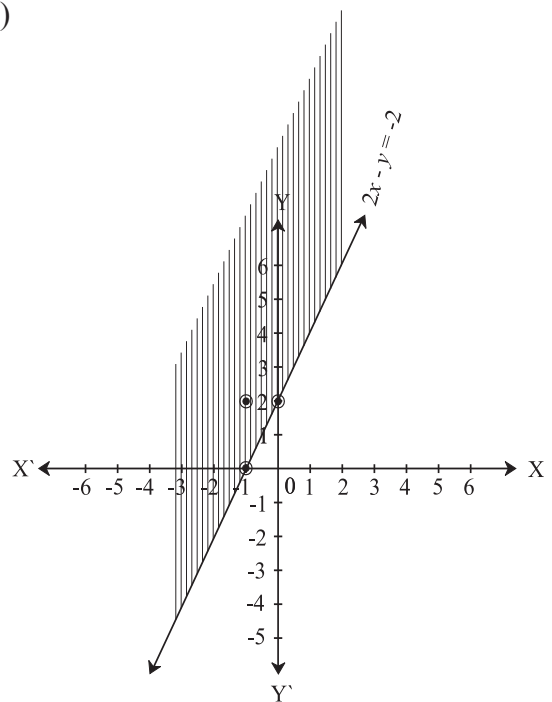

vii)

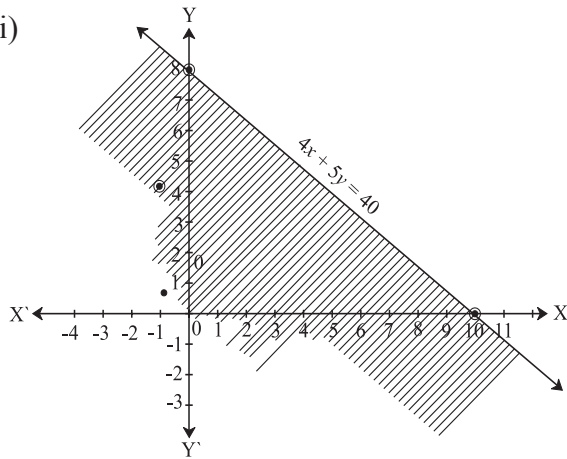

3) $200 F_1 + 100 F_2 \geq 4000$

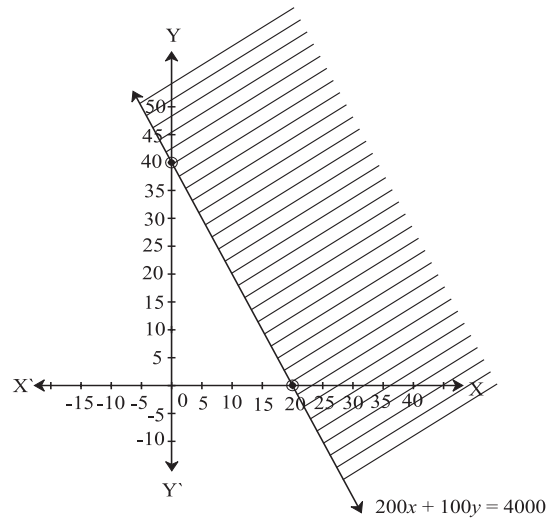

viii)

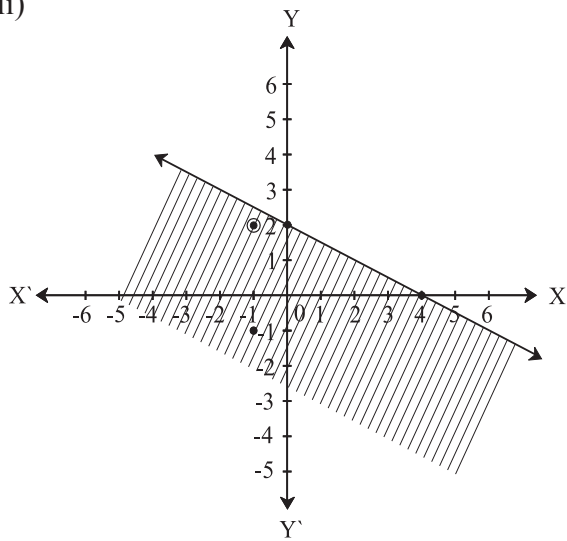

2) $150x + 200y \leq 1800$

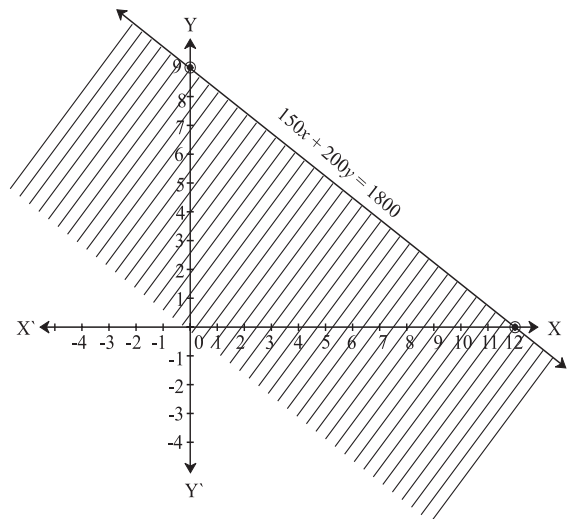

Exercise 8.3

1.

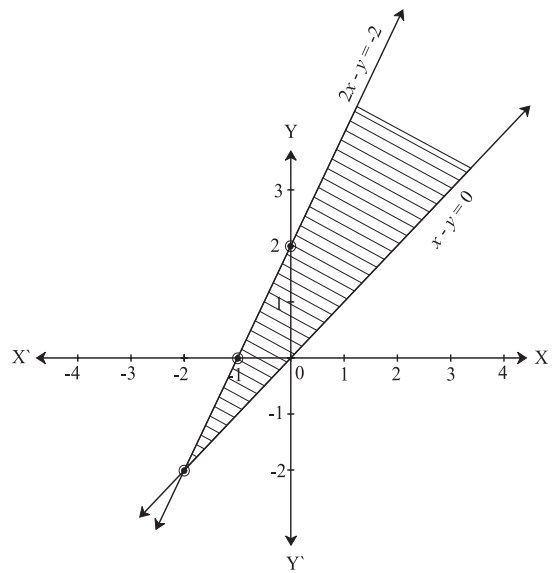

2.

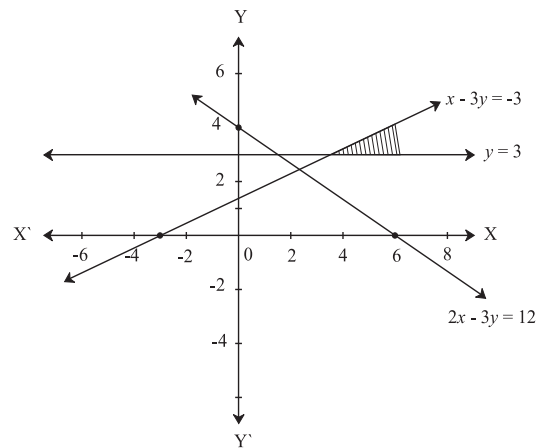

3.

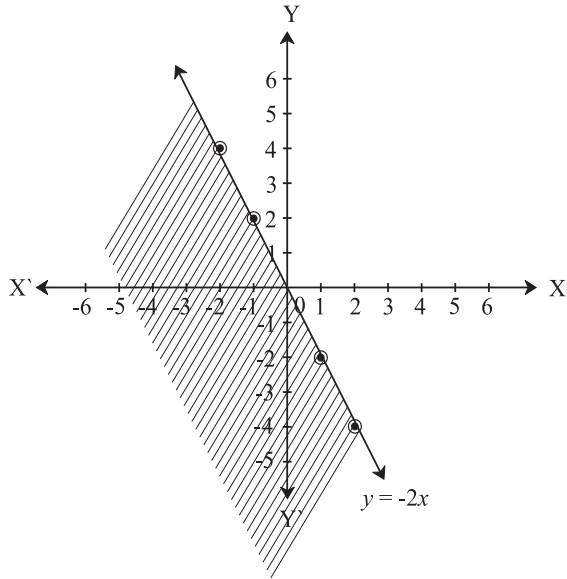

6.

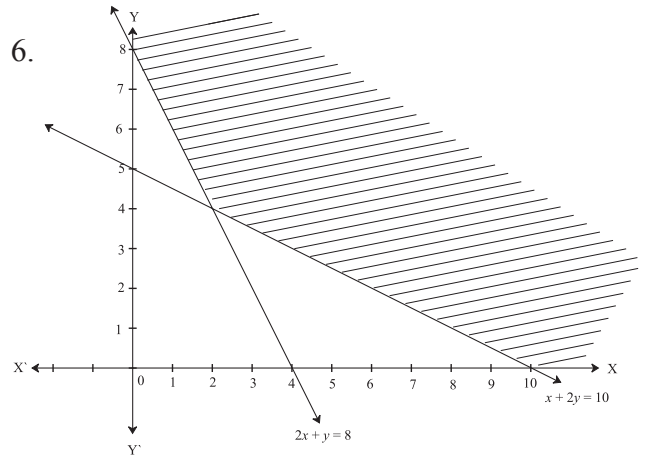

4.

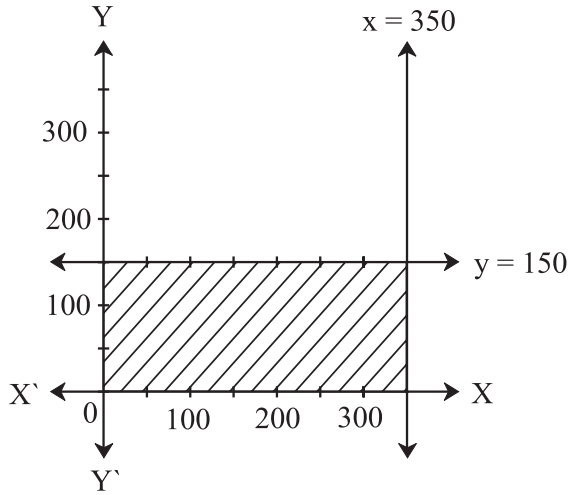

7.

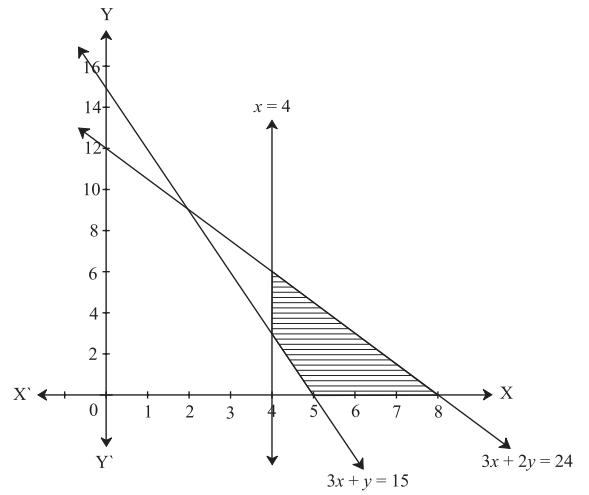

5.

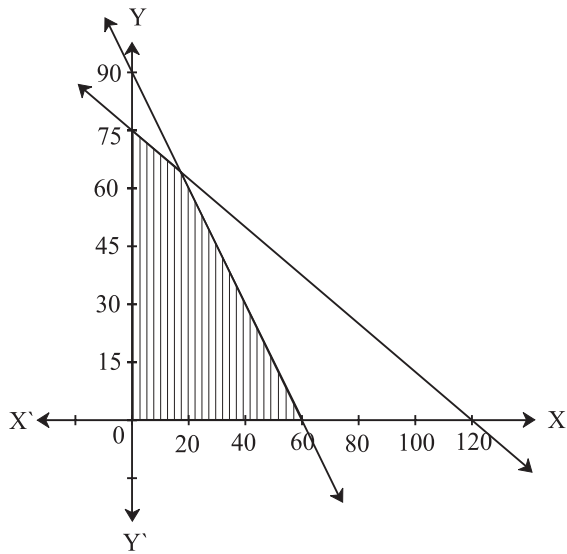

MISCELLANEOUS EXERCISE - 8

1.

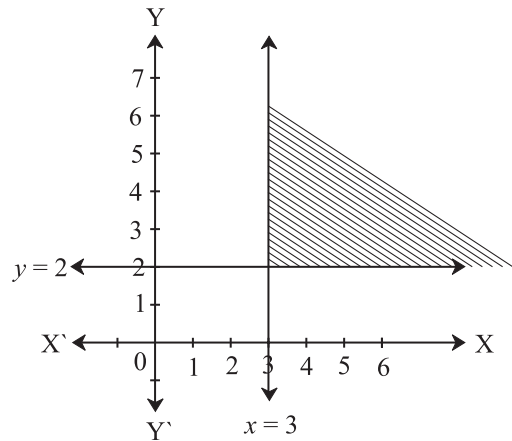

2.

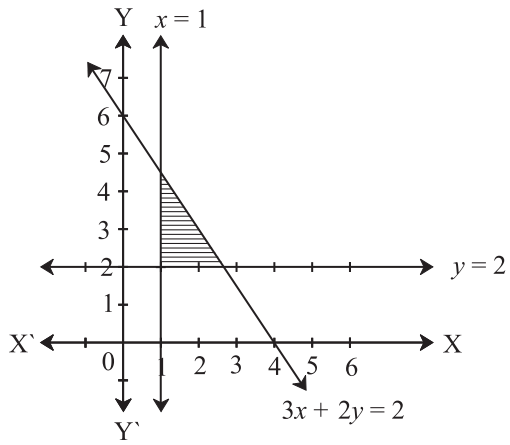

5.

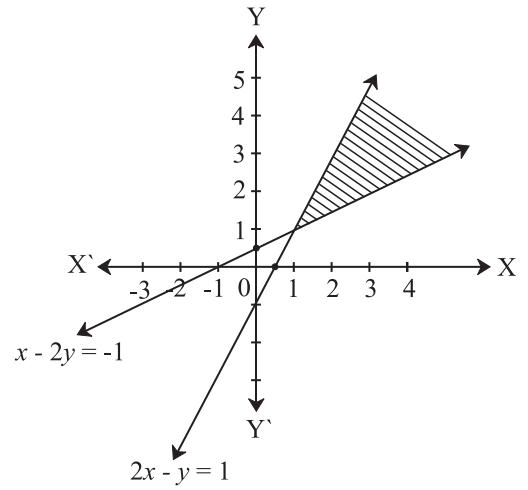

3.

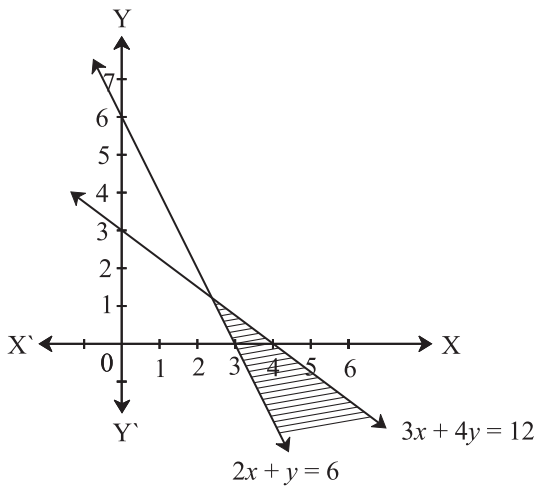

6.

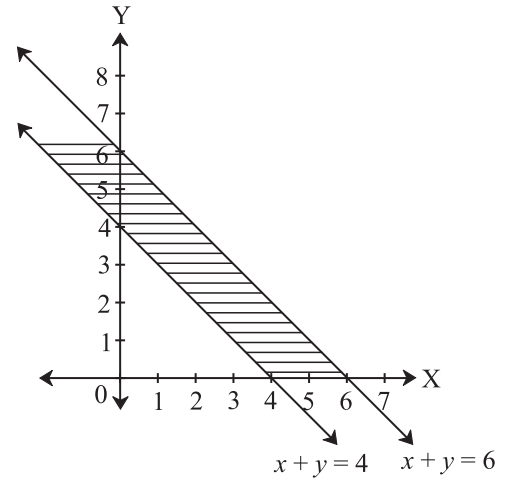

4.

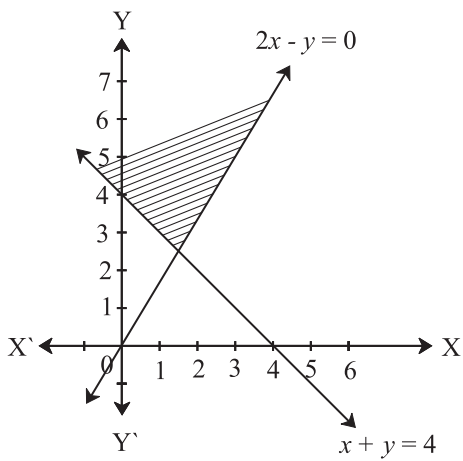

7.

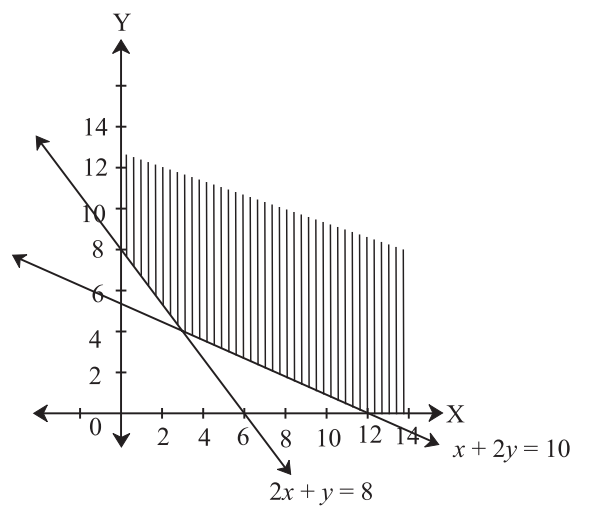

8.

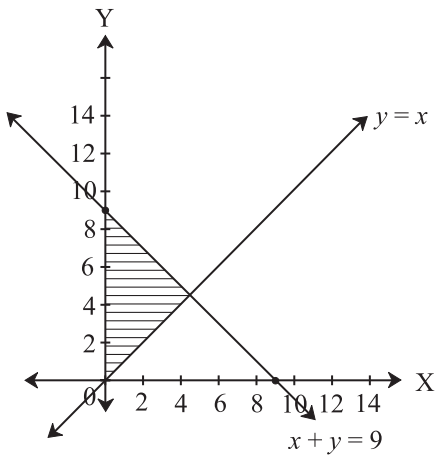

11.

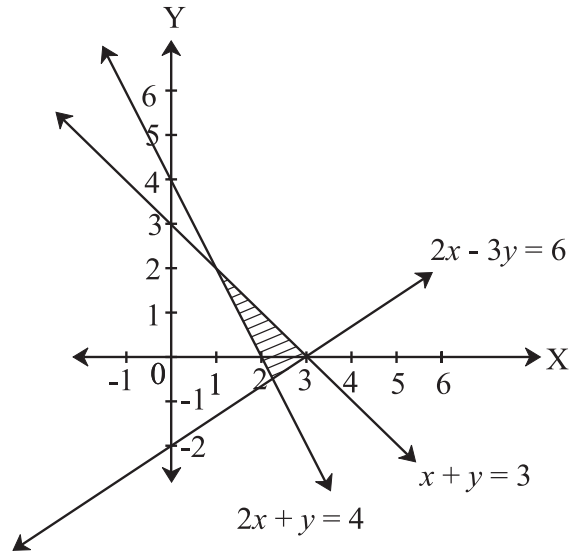

9.

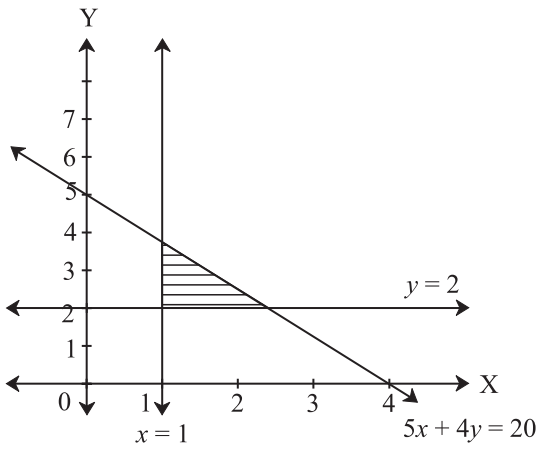

12.

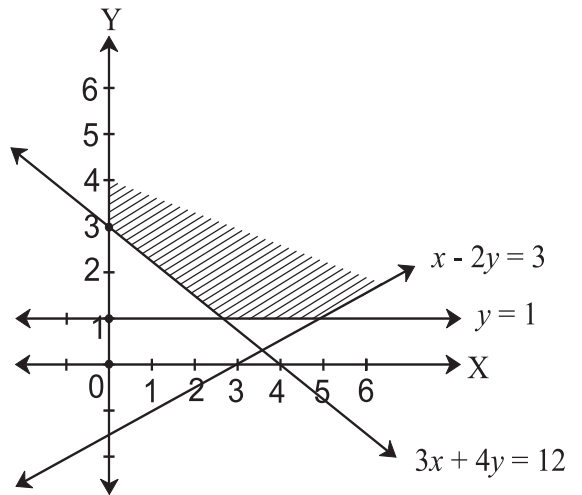

10.

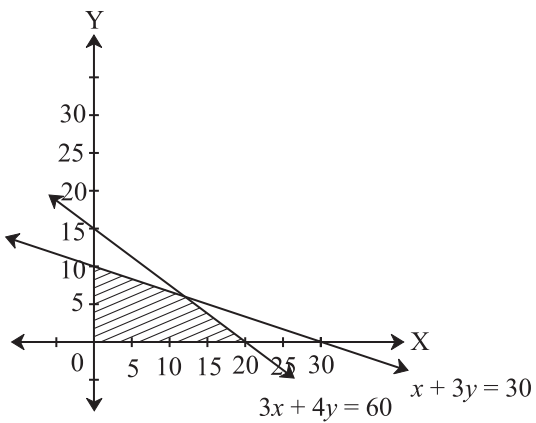

13.

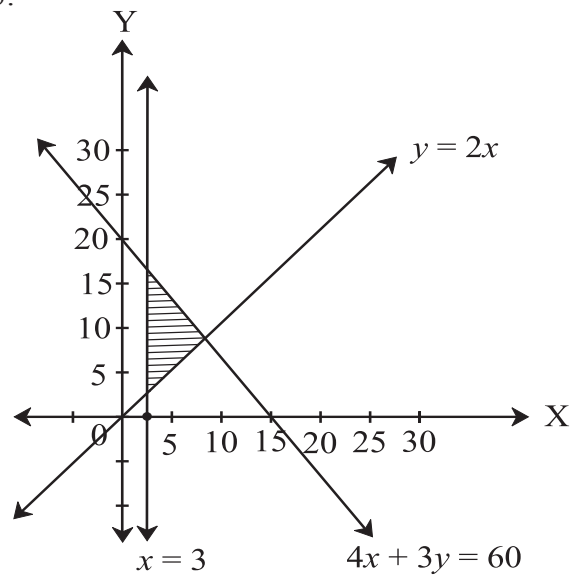

14.

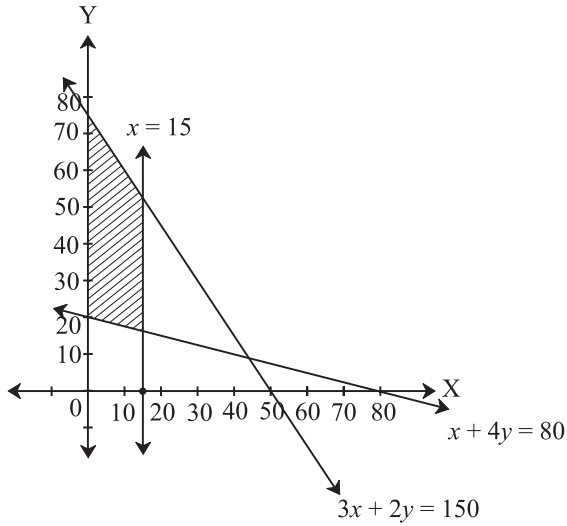

15.

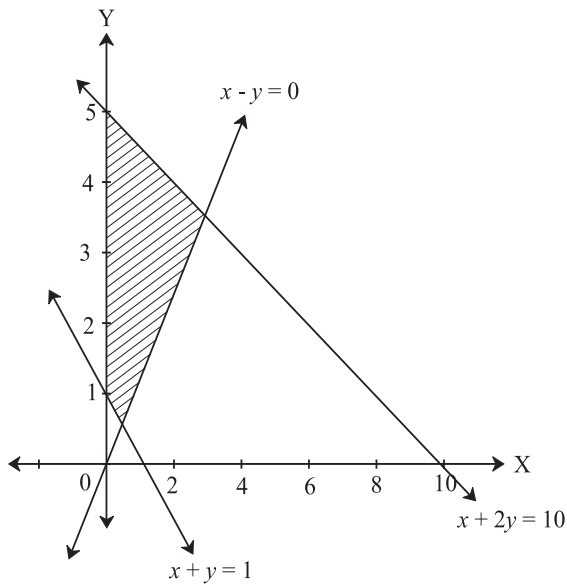

7. Rs.16
8. 28.57%
9. 50%

Exercise 9.2

1. 25%
2. Profit Rs.600
3. 5 toffees
4. Rs.3000
5. 0.8 cm.
6. 24%
7. Rs.540
8. 125%
9. 31.25%
10. Rs.1550
11. 19.6%
12. 50%
13. 20% (Rs.90)
14. Rs.200
15. Loss 2.25%

Exercise 9.3

1. Rs.1728
2. Rs.1428
3. Rs.519.75
4. Rs.662.025
5. Rs.1698.58
6. 3 years
7. 10 years
8. Rs. 500
9. Rs.630.5
10. Rs.2050
11. Rs.5000

CHAPTER 9

Exercise 9.1

1. 579.2
2. 85%
3. 2%
4. 25%
5. Rs.100
6. 0.15%

Exercise 9.4

- 1) Rs.180000 = Value after 2 years
- 2) Rs. = 12.5 = Rate of Depreciation
- 3) Purchase price of machine = 300000
- 4) No. of years = 3
- 5) Value after 3 years = Rs. 343000
- 6) Rate of depreciation $r = 10\%$
- 7) Value after 2 years = Rs.4512500
- 8) No of years $n = 4$

Exercise 9.5

1. 50:72:105
2. 3:4:7
3. Rs. 50,000
4. Rs. 4,000
5. Rs. 46,000
6. 11 months
7. 3/11
8. Rs. 50,000
9. Rs. 1,080
10. Rs. 59,000

Exercise 9.6

1. CGST = Rs.9650, SGST = Rs.9650
2. ITC = Rs.25,000, GST = Rs.4500
3. ITC = Rs. 60,000, GST = Rs.12,000
4. Activity
5. GST payable by Heena Enterprise = Rs. 4500
GST payable by Leena Traders = Rs. 5400 –
Rs. 4500 = Rs. 900
GST payable by Meena Beauty Products =

$$\text{Rs. } 7200 - \text{Rs. } 5400 = \text{Rs. } 1800$$

$$\text{CGST} = \text{Rs. } 3600 \quad \text{SGST} = \text{Rs. } 3600$$

6. Input Tax = Rs.1,40,000 , Output Tax = Rs. 2.24,000 , ITC = Rs. 1.40.000
CGST = (Rs. 70,000 + Rs.42000) = Rs. 1,12,000 ,SGST= Rs. 1,12,000
7. Bill Amount = Rs.399

Exercise 9.7

1. (i) First firm is paying better
(ii) Rs. 62,400
2. (i) Rs. 120
(ii) Rs.8400
3. First kind
4. (i) 50
(ii) Rs. 180
5. Rs.315; Rs. 675 less
6. Rs. 150
7. Tejas's
8. Rs 75
9. Rs. 800
10. (i) 200
(ii) Rs. 2400
11. Rs.2200
12. (i) 100
(ii) Rs.600
(iii) 712%
13. (i) Rs. 6400
(ii) 9.6 %
14. Rs.21,000
15. Rs. 2250
16. Rs. 25
17. (i) Rs. 9600
(ii) Rs. 960
(iii) Rs. 10%

18. (i) Rs. 42000
(ii) Rs. 4200
(iii) 10 %

MISCELLANEOUS EXERCISE - 9

- 1) Rs. 90000 = Annual Rent
2) Passing marks = 85
3) Loss = 25%
4) Gain = 50%
5) C. P.= Rs.400
6) Discount = 38.8%
7) Sum = 6000
8) Period = 2 years
9) Purchase Price = Rs. 10000
- 10) 10.75 meters
11) After 2 years
12) Investment in 'B' = Rs. 21000
13) Annual dividend = Rs.2000
14) B's share = Rs. 1600
15) Banta Invested for 11 months
16) Akash – Rs.9245.50
Sameer – Rs.5186.50
Sid – Rs.1804.00
17) CGST = SGST = Rs.61200
18) ITC = 48000
CGST = SGST = RS.9000



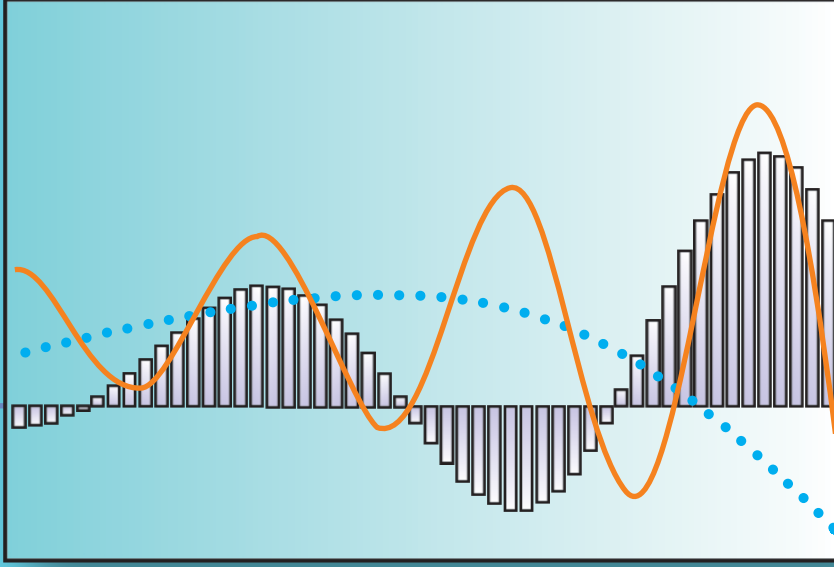

E-COMMERCE TRENDS IN INDIA



**Maharashtra State Bureau of Textbook
Production and Curriculum Research,
Pune - 411 004.**

₹ 98.00

इंग्रजी गणित आणि संख्याशास्त्र (वाणिज्य) भाग - २, इ. ११ वी